

NOTICE TO INSTALLER: Instructions must remain with installation.

Trusted. Tested. Tough.®

SECTION: 2.40.019
FM2527
0326
Supersedes
0222

Register your
Zoeller Pump Company
Product on our website:
<http://reg.zoellerpumps.com/>



MAIL TO: P.O. BOX 16347 • Louisville, KY 40256-0347
SHIP TO: 3649 Cane Run Road • Louisville, KY 40211-1961
Tel: (502) 778-2731 • 1 (800) 928-PUMP

Visit our website:
zoellerpumps.com

Product information presented here reflects conditions at time of publication. Consult factory regarding discrepancies or inconsistencies.

Jet Pumps Installation Instructions



Congratulations on the purchase of the Zoeller Potable Water Jet Pump. For over sixty years the name Zoeller has represented the standard for submersible sump and sewage pumps. The same high quality workmanship and easy maintenance design has been incorporated into this line of potable water products. This Zoeller system will provide years of trouble-free service when installed according to the manufacturer recommendations.

This manual incorporates the installation, operation, maintenance, and service instructions into one document to aid in the ownership of a Zoeller potable water product. Please read and review this manual before installing the product. Many items contained within, when followed correctly, will not only ensure a long and problem-free life for the system, but also save time and money during installation. Should further assistance be necessary please call our Technical Service department at 1-800-928-PUMP.

TABLE OF CONTENTS

Safety Instructions	1
Limited Warranty	2
Preinstallation Information	3
Installation Procedures	4-6
Troubleshooting Checklist	6
Notes	7

SAFETY INSTRUCTIONS

TO AVOID SERIOUS OR FATAL PERSONAL INJURY OR MAJOR PROPERTY DAMAGE, READ AND FOLLOW ALL SAFETY INSTRUCTIONS IN MANUAL AND ON PUMP.

THIS MANUAL IS INTENDED TO ASSIST IN THE INSTALLATION AND OPERATION OF THIS UNIT AND MUST BE KEPT WITH THE PUMP.



This is a **SAFETY ALERT SYMBOL**. When you see this symbol on the pump or in the manual, look for one of the following signal words and be alert to the potential for personal injury or property damage.

▲ DANGER

Warns of hazards that **WILL** cause serious personal injury, death or major property damage.

▲ WARNING

Warns of hazards that **CAN** cause serious personal injury, death or major property damage.

▲ CAUTION

Warns of hazards that **CAN** cause personal injury or property damage.

▲ NOTICE

Indicates special instructions which are very important and must be followed.

THOROUGHLY REVIEW ALL INSTRUCTIONS AND WARNINGS PRIOR TO PERFORMING ANY WORK ON THIS PUMP.

MAINTAIN ALL SAFETY DECALS.

OWNER'S INFORMATION

Model Number: _____ Date Code: _____

Job Name: _____

Dealer: _____

Date of Purchase: _____

Contractor: _____

Date of Installation: _____

System Readings During Operation: Voltage _____ Amps _____

LIMITED WARRANTY

Manufacturer warrants, to the purchaser and subsequent owner during the warranty period, every new product to be free from defects in material and workmanship under normal use and service, when properly used and maintained, for a period of one year from date of purchase by the end user, or 18 months from date of original manufacture of the product, whichever comes first. Parts that fail within the warranty period, one year from date of purchase by the end user, or 18 months from the date of original manufacture of the product, whichever comes first, that inspections determine to be defective in material or workmanship, will be repaired, replaced or remanufactured at Manufacturer's option, provided however, that by so doing we will not be obligated to replace an entire assembly, the entire mechanism or the complete unit. No allowance will be made for shipping charges, damages, labor or other charges that may occur due to product failure, repair or replacement.

This warranty does not apply to and there shall be no warranty for any material or product that has been disassembled without prior approval of Manufacturer, subjected to misuse, misapplication, neglect, alteration, accident or act of God; that has not been installed, operated or maintained in accordance with Manufacturer's installation instructions; that has been exposed to outside substances including but not limited to the following: sand, gravel, cement, mud, tar, hydrocarbons, hydrocarbon derivatives (oil, gasoline, solvents, etc.), or other abrasive or corrosive substances, wash towels or feminine sanitary products, etc. in all applications other than in raw sewage pumping applications. The warranty set out in the paragraph above is in

lieu of all other warranties expressed or implied; and we do not authorize any representative or other person to assume for us any other liability in connection with our products.











Contact Manufacturer at, 3649 Cane Run Road, Louisville, Kentucky 40211, Attention: Customer Service Department to obtain any needed repair or replacement of part(s) or additional information pertaining to our warranty.

MANUFACTURER EXPRESSLY DISCLAIMS LIABILITY FOR SPECIAL, CONSEQUENTIAL OR INCIDENTAL DAMAGES OR BREACH OF EXPRESSED OR IMPLIED WARRANTY; AND ANY IMPLIED WARRANTY OF FITNESS FOR A PARTICULAR PURPOSE AND OF MERCHANTABILITY SHALL BE LIMITED TO THE DURATION OF THE EXPRESSED WARRANTY.

Some states do not allow limitations on the duration of an implied warranty, so the above limitation may not apply to you. Some states do not allow the exclusion or limitation of incidental or consequential damages, so the above limitation or exclusion may not apply to you.

This warranty gives you specific legal rights and you may also have other rights which vary from state to state.

PREINSTALLATION INFORMATION

- Inspect your unit.** Occasionally, products are damaged during shipment. If the unit is damaged, contact your dealer before using.
- Carefully read the literature** provided to familiarize yourself with specific details regarding installation and use. These materials should be retained for future reference.
-  **WARNING** "Risk of electrical shock" Do not remove power supply cord and strain relief or connect conduit directly to the pump. Installation and checking of electrical circuits and hardware should be performed by a qualified and licensed electrician.
-  **WARNING** Do not lift, carry, or hang pump by the electrical cables. Damage to the electrical cables can cause shock, burns or death.
-  **WARNING** For your protection, make certain the pump ground wire is properly connected to the ground wire with the incoming power line. Test for ground at the junction box using an Underwriters Laboratory listed circuit analyzer which will indicate if the power, neutral and ground wires are correctly connected. If in doubt, call a qualified licensed electrician.
-  **WARNING** Make certain that the receptacle is within the reach of the pump's power supply cord. **DO NOT USE AN EXTENSION CORD.** Extension cords that are too long or too light do not deliver sufficient voltage to the pump motor. But, more important, they could present a safety hazard if the insulation were to become damaged or the connection end were to get wet.
-  **WARNING** Make sure the pump electrical supply circuit is equipped with fuses or circuit breakers of proper capacity. A separate branch circuit is recommended, and sized according to the "National Electrical Code" for the current shown on the pump nameplate.
-  **WARNING** Pump is designed to pump cold ground water that is free of air or gases. Decreased pump performance and life expectancy can occur if the ground water is not cold (86 °F/30 °C) or contains air or gases.
-  **WARNING** **DO NOT** run the pump dry. **DO NOT** run the pump with a completely closed discharge. **DO NOT** pump chemical or corrosive liquids. Failure to follow above warnings could result in damage to the pump, voiding the warranty and causing personal injury.
-  **CAUTION** Check to be sure your power source is capable of handling the voltage requirements of the motor, as indicated on the pump nameplate.
- The installation of pumps using auxiliary variable level float switches is the responsibility of the installing party. Care should be taken such that the tethered float switch will not hang up and are secured so that the pump will turn on and off properly.
-  **CAUTION** Water hammer creates momentary high pressure surges. These surges can cause severe damage to check valves and the piping system. Consideration for water hammer must be included in the piping system design. Reference ASPE Data Book, Chapter 2.33. Some systems may require external spring or lever weighted check valves or other engineered solutions.
-  **CAUTION** In cold climates the discharge pipe may be subject to freezing. If the riser on the septic tank is above the frost line, it will be necessary to protect the system from freeze up. The discharge pipe can be insulated or the check valve can be removed. If the check valve is removed, the "on-off" cycle must be adjusted for any back-flow from the discharge line.
-  **WARNING** Prop65 Warning for California residents: Cancer and Reproductive Harm- www.P65warnings.ca.gov.

READ THESE INSTRUCTIONS CAREFULLY BEFORE INSTALLATION

LOCATION

1. Pump can be located at the well or can be offset some distance away from the well. For best performance it should be located as close to the well as possible.
2. Location can be in the basement, a pit below ground or in a pump house above ground.
3. Ventilation and drainage must be provided to prevent damage from moisture to the motor and pressure switch.
4. The pump and all piping must be protected from freezing.
5. Pump and pipe line must be drained when not in use if there is any danger of freezing.

WELL CONDITIONS

1. New wells should be pumped clean of all sand and foreign matter before installing the pump or damage may result to the operating parts.
2. The foot valve should be installed a minimum of five (5) feet from the bottom of the well to prevent sand, mud or other foreign matter from entering the system.
3. The well must be capable of furnishing a sufficient quantity of water to satisfy the demands of the pump and personal needs. The water level must not draw down below the maximum rated depth of the pump or loss of capacity and prime will result.
4. For sanitary reasons, install a well seal or pitless adapter as required and in accordance with local and state codes.

PIPING

1. Old or badly scaled pipe should not be used because dislodged flakes of scale can cause stoppage of the ejector nozzle and malfunction the entire system.
2. Use only pipe in good condition free from rust and scale. Threads should be sharp, cleanly cut with a minimum of two (2) threads remaining when connection is completely drawn up.
3. On galvanized steel pipe installations, the ends should be reamed to insure maximum capacity.
4. All joints and connections should be doped (male threads only) and drawn up tightly.

CAUTION The entire system must be air and water tight for efficient operation.

TYPE OF PIPE

1. Plastic or galvanized steel pipe may be used in the installation of jet pumps.
2. Plastic pipe must have a minimum pressure rating of 160 PSI.

WELL TO PUMP PIPING

1. All offset piping should slope upwards from well to pump.
2. Avoid dips or pockets in offset piping or air will accumulate at high points which will make priming difficult.
3. Install unions at pump and at well to aid in servicing.
4. Allow enough room around pump and piping installation for using pipe wrenches and for service and installation.
5. Do not use piping of sizes smaller than those listed in Chart 1 or pump will not operate properly.

CHART 1

Recommended Suction Pipe Sizes for Shallow Well Pump				
Length Of Offset From Well, In Feet				
Vertical Piping	0 - 20'	20 - 100'	100 - 200'	200 - 400'
1"	1"	1-1/4"	1-1/2"	2"

EJECTOR AND PRESSURE SWITCH ATTACHMENT

1. Attach ejector to face of pump with two (2) bolts and gasket provided. Venturi tube on the ejector inserts in the top tapping of the face of the pump (Figure 1).
2. Screw pressure switch into tapping on side of pump as shown (Figure 2).
3. Remove pressure switch cover to expose wiring terminals. Insert motor lead wire through side hole of the pressure switch box and attach to the two (2) flag terminals marked "load". Leave switch cover off for later connection of the power supply line.

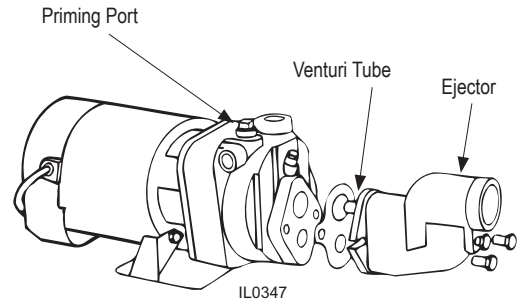

FIGURE 1

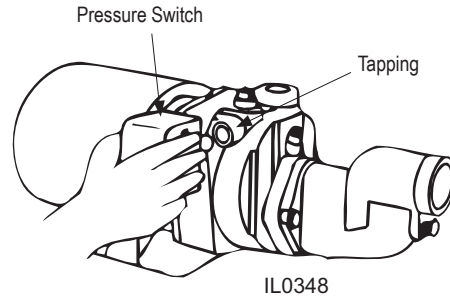
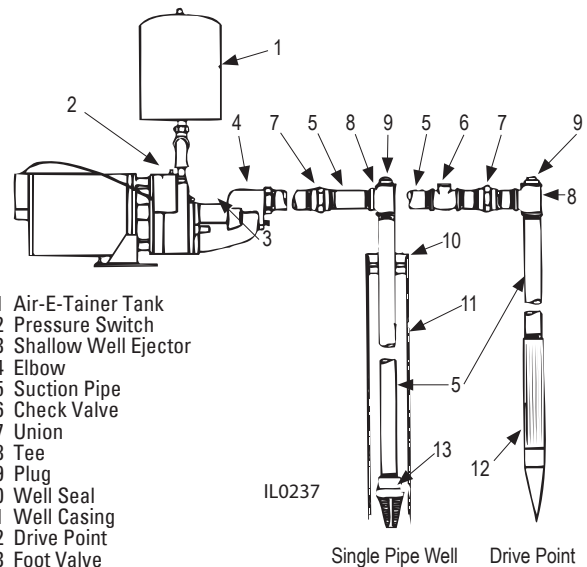

FIGURE 2

NOTE: For the pump to operate, the venturi tube of the ejector must be positioned into the top tapping of the face of the pump.

WELL TO PUMP INSTALLATION

1. On single pipe installation (see Figure 3) attach foot valve to the end of the suction line and set in the well making certain the valve is below the water level. The foot valve should be at least five (5) feet from the bottom of the well to prevent sand from being drawn into the system.
2. When connecting a drive point (Figure 3) a check valve must be used in the suction line in place of a foot valve. For easy priming connect the check valve as close to the well as possible.
3. All piping from the well to the pump should slope slightly upward. Unions in the suction line near the pump and well will aid in servicing. Be sure to leave enough room so that wrenches can be used without difficulty.



PUMP INSTALLATION

FIGURE 3 — Shallow Well with Air-E-Tainer Tank, Single Pipe or Drive Point

PRESSURE TANK HOOKUP

1. Conventional pressure tanks require an air volume control to insure the proper air to water ratio in the pressure tank. On shallow well installations, the air volume control tubing is connected to the 1/4" tapping on the side of the ejector (Figure 4).
2. Air-E-Tainer tanks are equipped with a diaphragm or bladder that keeps the air and water from mixing. Since these tanks are factory precharged with air, an air volume control is not required.
3. To check tank air pressure, use a good tire pressure gauge. Do not add air to tank unless tank is empty of water.
4. On vertical tank installation where the pump is offset from the tank, galvanized steel or plastic pipe can be used to connect the pump to the tank. To assist in servicing, place shut-off valve and union in line as shown in Figure 4.

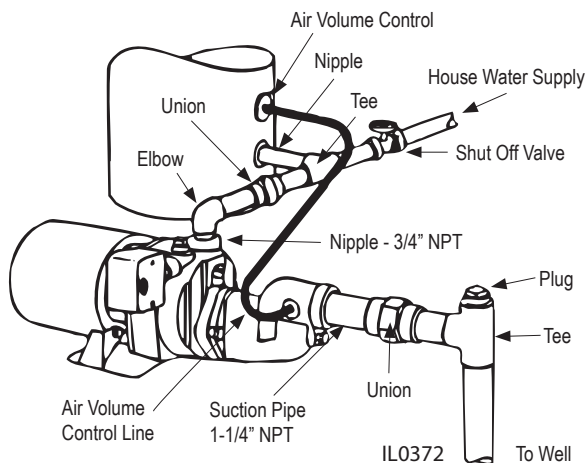

FIGURE 4

- 5. NOTE: DO NOT install a check valve between pump and pressure tank. This will cause the pressure switch to malfunction.**

WIRING

1. The motor is suitable for use with 60 Hz A.C. current only. The motor is dual voltage and may be field connected for either 115V or 230V field service. The unit is factory connected per the label on the pump motor next to the power cord.

NOTE: See the following wiring diagram or the motor nameplate if a change is required. Always use the higher voltage where possible.

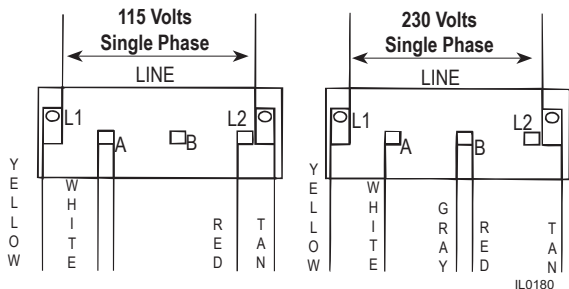

NOTE: Dual voltage motor, change the red and gray wire to voltage required.

FIGURE 5 — Dual Voltage Wiring Diagram

2. To change voltage, remove the rear access cover of the motor, which is held in place with two (2) screws. Change the red and gray wire on the transfer switch board to the voltage required.

WARNING Replace rear access cover before starting or operating pump. Failure to do so can result in personal injury.

3. Your pump motor has a built-in thermal overload that protects the motor

against burnout from overload of low voltage, high voltage and other causes. The device is automatic and resets itself once the temperature has dropped to a safe point. Frequent tripping of the device indicates trouble in the motor or power lines and immediate attention is needed.

CAUTION Never examine, make wiring changes or touch the motor before disconnecting the main electrical supply switch. The thermal device may have opened the electrical circuit.

4. Undersize wiring can cause motor failure (low voltage), frequent cut-out of motor overload protector, television interference and even fire. Make certain the wiring is adequately sized (Chart 2), well insulated and connected to a separate circuit outside the house in case of fire. For added safety, the pump and motor should be securely grounded to the well casing or to a separate ground rod driven eight (8) feet into the ground. Consult local codes before attempting a wiring installation.
5. When fusing the pump service entrance box, consult Chart 2 for proper fuse size. Consult local codes before attempting a wiring installation. Use only the fuse that is stipulated for your particular installation. Never use one larger. Service should never be reinstated to the pump motor by attempting to circumvent a blown fuse by any other means.
6. The pressure switch is wired to the motor by connecting the motor lead to the two (2) inside terminals of the pressure switch. Connect the power lines to pressure switch terminals marked L-1 and L-2.

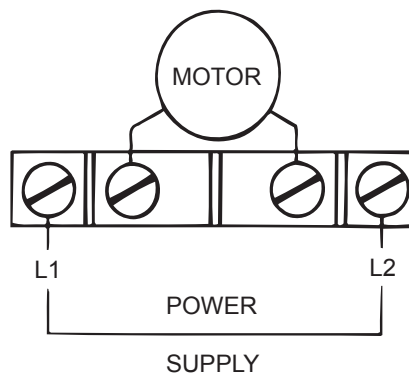

FIGURE 6

PRIMING

CAUTION Before starting motor, the pump body must be completely filled with water. Running the pump dry will cause seal damage.

1. Remove priming plug from the priming opening. Pour in water continuously until all air has been expelled from pump and suction line. If tee has been provided at the well head the suction pipe in the well can be filled at this point.
2. Replace plug, screwing in only far enough to seal, and start the motor. If pump fails to build up pressure within three (3) minutes, shut off pump and prime again. Once the pump is primed, tighten priming plug completely.

PUMP INSTALLATION (continued)

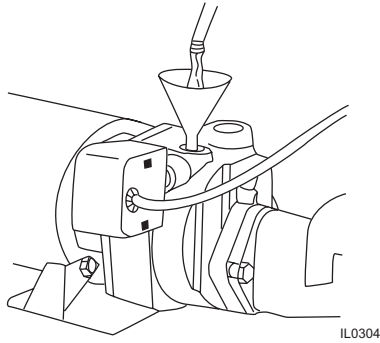

FIGURE 7
MAINTENANCE

1. Lubrication - The pumps and motors require no lubrication. The ball bearings of the motor have been greased at the factory and under normal operating conditions should require no further greasing.
2. Freezing - Drain the entire system if there is danger of freezing. A drain plug is provided at the bottom of the pump case for this purpose.

ROTARY SEAL ASSEMBLY REPLACEMENT (FIGURE 5)

⚠ CAUTION Make certain that the power supply is disconnected before attempting to service the unit! The rotary seal assembly must be handled carefully to avoid damaging the precision lapped faces of the sealing components.

1. Disengage pump body (Ref. No. 8) from motor mounting ring (Ref. No. 2).
2. Remove diffuser (Ref. No. 7).
3. Remove impeller (Ref. No. 6) by unthreading counter clockwise while looking into the eye of the impeller. To hold motor shaft, use the screwdriver slot at the impeller eye.
4. The rotary seal (Ref. No. 4) will come loose at this time. Use a screwdriver (or similar instrument) to pry the ceramic seal and rubber gasket from the recess of the mounting bracket.

⚠ CAUTION Be careful not to damage the motor shaft or recess surface.

5. Clean the recess and motor shaft thoroughly.
6. Install the new rotary seal assembly.
 - a. Insert the ceramic seal and the rubber gasket into the recess.
- NOTE:** To help facilitate installation, apply a drop of liquid soap to the outside diameter of the rubber gasket. Make certain that the ceramic seal is kept clean and free of dirt and/or oil.
- b. Slip the remaining parts of the rotary seal assembly onto the motor shaft.
- NOTE:** Apply a drop of liquid soap to the inside diameter of the rubber drive ring.
7. Replace the impeller and diffuser removed in Steps 2 & 3.
8. Reassemble the pump body to the motor and mounting bracket.

MOTOR REPLACEMENT (FIGURE 5)

1. Uni-Frame motors can be replaced in the field with any standard Nema J jet pump motor by following the following instructions.

⚠ CAUTION Before attempting to replace the motor, make certain that the power supply is disconnected and the system pressure is relieved.

2. Remove pump body (Ref. No. 8) diffuser (Ref. No. 7), impeller (Ref. No. 6) and shaft seal (Ref. No. 4) by following steps 1, 2, 3 & 4 of Rotary Seal Replacement.
3. Uni-Frame motors (indicated by 56U in the frame "FR" block on the motor decal) can be removed as follows:
 - a. Disassemble pump base (Ref. No. 3) from unit by removing two (2) 3/8" hex nuts.
 - b. Remove four (4) thru bolts from rear of motor and pull away shell and stator assembly (discard).
 - c. Disconnect four (4) self tapping screws that hold the bearing housing to the mounting ring. Discard bearing housing, rotor assembly and (2) square headed screws.
4. Replace motor with standard Nema J jet pump motor by positioning motor against the mounting frame and assembling with four (4) 3/8" x 3/4" cap screws. The mounting base is connected at the bottom of the mounting frame with two (2) of the four (4) 3/8" x 3/4" cap screws.
5. Follow steps 5, 6, 7 and 8 of Rotor Seal Assembly to reassemble the remainder of the pump. Because damage to the shaft seal is most likely to occur in disassembly, a new seal will be necessary.

CHART 2

Motor HP	Volts	Phase	Distance in Feet from Motor to Service Panel					Breaker Size (Amps)
			0-50 Ft.	50-100 Ft.	100-150 Ft.	150-200 Ft.	200-300 Ft.	
			Wire Size					
1/2	115/230	1	14/14	14/14	14/14	12/14	12/14	15/15
3/4	115/230	1	12/14	12/14	12/14	12/14	10/14	20/15

TROUBLESHOOTING

Symptom	Possible Cause(s)	Corrective Action
Pump won't start or run.	<ol style="list-style-type: none"> 1. Blown fuse. 2. Low line voltage. 3. Loose, broken or incorrect wiring. 4. Defective motor. 5. Defective pressure switch. 6. Impeller or seal. 7. Bad capacitor. 	<ol style="list-style-type: none"> 1. If blown, replace with fuse of proper size. Use time delay fuses. 2. If voltage under recommended minimum, check size of wiring from main switch on property. If OK, contact power company. 3. Rewire any incorrect circuits. Tighten connections, replace defective wires. 4. Replace. 5. Adjust switch settings. Clean contacts with emery cloth if dirty. 6. If impeller won't turn, remove housing and locate source of binding. 7. Replace.
Pump starts and stops too often.	<ol style="list-style-type: none"> 1. Leak in pressure tank. 2. Defective air volume control. 3. Faulty pressure switch. 4. Leak on discharge side of system. 5. Leak on suction side of system. 6. Leak in foot valve. 	<ol style="list-style-type: none"> 1. Repair leaks or replace tank. 2. Clean or replace defective control. 3. Adjust switch settings. Clean contacts with emery cloth if dirty. 4. Repair leaks as necessary. 5. Make sure above ground connections are tight. Then repeat test. If necessary, pull piping and repair leak. 6. Repair or replace.
Pump won't shut off.	<ol style="list-style-type: none"> 1. Wrong pressure switch setting or setting "drift". 2. Defective pressure switch. 3. Loss of prime. 4. Low well level. 5. Fouled ejector. 	<ol style="list-style-type: none"> 1. Adjust switch to proper setting. 2. Replace switch if defective. 3. Reprime if necessary. 4. If undersized, replace pump or ejector. 5. Clean.
Pump operates, but delivers little or no water.	<ol style="list-style-type: none"> 1. Low line voltage. 2. System incompletely primed. 3. Air lock in suction line. 4. Undersized piping. 5. Leak in air volume control or tubing. 6. Leak on suction side of system. 7. Low well capacity. 8. Plugged ejector. 9. Defective or plugged foot valve and/or strainer. 10. Worn or defective pump parts or plugged impeller. 	<ol style="list-style-type: none"> 1. If voltage under recommended minimum, check size of wiring from main switch on property. If OK, contact power company. 2. Reprime if necessary. 3. Rearrange piping to eliminate air lock. 4. Replace undersized piping or install pump with higher capacity. 5. Tighten all fittings and replace control if necessary. 6. Make sure above ground connections are tight. Repeat test. If necessary, pull piping and repair leak. 7. Close down the valve on discharge side of pump to limit flow of water, in keeping with well capacity. 8. Clean and reinstall if dirty. 9. Clean, repair or replace as needed. 10. Replace worn parts or pump. Clean parts if required.

NOTES



MAIL TO: P.O. BOX 16347 • Louisville, KY 40256-0347
SHIP TO: 3649 Cane Run Road • Louisville, KY 40211-1961
Tel: (502) 778-2731 • 1 (800) 928-PUMP

Trusted. Tested. Tough.®

Visit our website:
zoellerpumps.com