

NOTICE TO INSTALLER: Instructions must remain with installation.

FM2524
0326
Supersedes
0415

Trusted. Tested. Tough.®



MAIL TO: P.O. BOX 16347 • Louisville, KY 40256-0347
SHIP TO: 3649 Cane Run Road • Louisville, KY 40211-1961
Tel: (502) 778-2731 • 1 (800) 928-PUMP

Visit our website:
zoellerpumps.com

Register your
Zoeller Pump Company
Product on our website:
<http://reg.zoellerpumps.com/>

Product information presented here reflects conditions at time of publication. Consult factory regarding discrepancies or inconsistencies.

Four Inch Submersible Well Pumps Installation Instructions



Congratulations on the purchase of the Zoeller Potable Water Submersible Turbine Pump. Since 1939, the name Zoeller has represented the standard for submersible sump and sewage pumps. The same high quality workmanship and easy maintenance design has been incorporated into this line of potable water products. This Zoeller system will provide years of trouble-free service when installed according to the manufacturer recommendations.

This manual incorporates the installation, operation, maintenance, and service instructions into one document to aid in the ownership of a Zoeller potable water product. Please read and review this manual before installing the product. Many items contained within, when followed correctly, will not only ensure a long and problem-free life for the system, but also save time and money during installation. Should further assistance be necessary please call our Technical Support department at 1-800-928-PUMP.

TABLE OF CONTENTS

Safety Instructions	1
Limited Warranty	2
Preinstallation Information	2
Electrical & Cable Selection Data	3
Installation Procedures	4-10
Troubleshooting Checklist	10
Pump Specifications	11
Notes	12

SAFETY INSTRUCTIONS

TO AVOID SERIOUS OR FATAL PERSONAL INJURY OR MAJOR PROPERTY DAMAGE, READ AND FOLLOW ALL SAFETY INSTRUCTIONS IN MANUAL AND ON PUMP.

THIS MANUAL IS INTENDED TO ASSIST IN THE INSTALLATION AND OPERATION OF THIS UNIT AND MUST BE KEPT WITH THE PUMP.



This is a SAFETY ALERT SYMBOL. When you see this symbol on the pump or in the manual, look for one of the following signal words and be alert to the potential for personal injury or property damage.

- ▲ DANGER** Warns of hazards that WILL cause serious personal injury, death or major property damage.
- ▲ WARNING** Warns of hazards that CAN cause serious personal injury, death or major property damage.
- ▲ CAUTION** Warns of hazards that CAN cause personal injury or property damage.
- ▲ NOTICE** Indicates special instructions which are very important and must be followed.

THOROUGHLY REVIEW ALL INSTRUCTIONS AND WARNINGS PRIOR TO PERFORMING ANY WORK ON THIS PUMP.

MAINTAIN ALL SAFETY DECALS.

OWNER'S INFORMATION

Model Number: _____ Date Code: _____

Job Name: _____

Dealer: _____

Date of Purchase: _____

Contractor: _____

Date of Installation: _____

System Readings During Operation: Voltage _____ Amps _____

LIMITED WARRANTY

Manufacturer warrants, to the purchaser and subsequent owner during the warranty period, every new product to be free from defects in material and workmanship under normal use and service, when properly used and maintained, for a period of one year from date of purchase by the end user, or 18 months from date of original manufacture of the product, whichever comes first. Parts that fail within the warranty period, one year from date of purchase by the end user, or 18 months from the date of original manufacture of the product, whichever comes first, that inspections determine to be defective in material or workmanship, will be repaired, replaced or remanufactured at Manufacturer's option, provided however, that by so doing we will not be obligated to replace an entire assembly, the entire mechanism or the complete unit. No allowance will be made for shipping charges, damages, labor or other charges that may occur due to product failure, repair or replacement.

This warranty does not apply to and there shall be no warranty for any material or product that has been disassembled without prior approval of Manufacturer, subjected to misuse, misapplication, neglect, alteration, accident or act of God; that has not been installed, operated or maintained in accordance with Manufacturer's installation instructions; that has been exposed to outside substances including but not limited to the following: sand, gravel, cement, mud, tar, hydrocarbons, hydrocarbon derivatives (oil, gasoline, solvents, etc.), or other abrasive or corrosive substances, wash towels or feminine sanitary products, etc. in all applications other than in raw sewage pumping applications. The warranty set out in the paragraph

above is in lieu of all other warranties expressed or implied; and we do not authorize any representative or other person to assume for us any other liability in connection with our products.











Contact Manufacturer at, 3649 Cane Run Road, Louisville, Kentucky 40211, Attention: Customer Service Department to obtain any needed repair or replacement of part(s) or additional information pertaining to our warranty.

MANUFACTURER EXPRESSLY DISCLAIMS LIABILITY FOR SPECIAL, CONSEQUENTIAL OR INCIDENTAL DAMAGES OR BREACH OF EXPRESSED OR IMPLIED WARRANTY; AND ANY IMPLIED WARRANTY OF FITNESS FOR A PARTICULAR PURPOSE AND OF MERCHANTABILITY SHALL BE LIMITED TO THE DURATION OF THE EXPRESSED WARRANTY.

Some states do not allow limitations on the duration of an implied warranty, so the above limitation may not apply to you. Some states do not allow the exclusion or limitation of incidental or consequential damages, so the above limitation or exclusion may not apply to you.

This warranty gives you specific legal rights and you may also have other rights which vary from state to state.

PREINSTALLATION INFORMATION

- Inspect your unit.** Occasionally, products are damaged during shipment. If the unit is damaged, contact your dealer before using.
- Carefully read the literature** provided to familiarize yourself with specific details regarding installation and use. These materials should be retained for future reference.
-  **▲ WARNING** "Risk of electrical shock" Do not remove power supply cord and strain relief or connect conduit directly to the pump. Installation and checking of electrical circuits and hardware should be performed by a qualified and licensed electrician.
-  **▲ WARNING** Do not lift, carry, or hang pump by the electrical cables. Damage to the electrical cables can cause shock, burns or death.
-  **▲ WARNING** For your protection, make certain the pump ground wire is properly connected to the ground wire with the incoming power line. Test for ground at the junction box using an Underwriters Laboratory listed circuit analyzer which will indicate if the power, neutral and ground wires are correctly connected. If in doubt, call a qualified licensed electrician.
-  **▲ WARNING** Make certain that the receptacle is within the reach of the pump's power supply cord. **DO NOT USE AN EXTENSION CORD.** Extension cords that are too long or too light do not deliver sufficient voltage to the pump motor. But, more important, they could present a safety hazard if the insulation were to become damaged or the connection end were to get wet.
-  **▲ WARNING** Make sure the pump electrical supply circuit is equipped with fuses or circuit breakers of proper capacity. A separate branch circuit is recommended, and sized according to the "National Electrical Code" for the current shown on the pump nameplate.
-  **▲ WARNING** Pump is designed to pump cold ground water that is free of air or gases. Decreased pump performance and life expectancy can occur if the ground water is not cold (86°F/30°C) or contains air or gases.
-  **▲ WARNING** **DO NOT** run the pump dry. **DO NOT** run the pump with a completely closed discharge. **DO NOT** pump chemical or corrosive liquids. Failure to follow above warnings could result in damage to the pump, voiding the warranty and causing personal injury.
-  **▲ CAUTION** Check to be sure your power source is capable of handling the voltage requirements of the motor, as indicated on the pump nameplate.
- The installation of pumps using auxiliary variable level float switches is the responsibility of the installing party. Care should be taken such that the tethered float switch will not hang up and are secured so that the pump will turn on and off properly.
-  **▲ CAUTION** Water hammer creates momentary high pressure surges. These surges can cause severe damage to check valves and the piping system. Consideration for water hammer must be included in the piping system design. Reference ASPE Data Book, Chapter 2.33. Some systems may require external spring or lever weighted check valves or other engineered solutions.
-  **▲ CAUTION** In cold climates the discharge pipe may be subject to freezing. If the riser on the septic tank is above the frost line, it will be necessary to protect the system from freeze up. The discharge pipe can be insulated or the check valve can be removed. If the check valve is removed, the "on-off" cycle must be adjusted for any back-flow from the discharge line.
-  **▲ WARNING** Prop65 Warning for California residents: Cancer and Reproductive Harm- www.P65warnings.ca.gov.

SUBMERSIBLE PUMP INSTALLATION

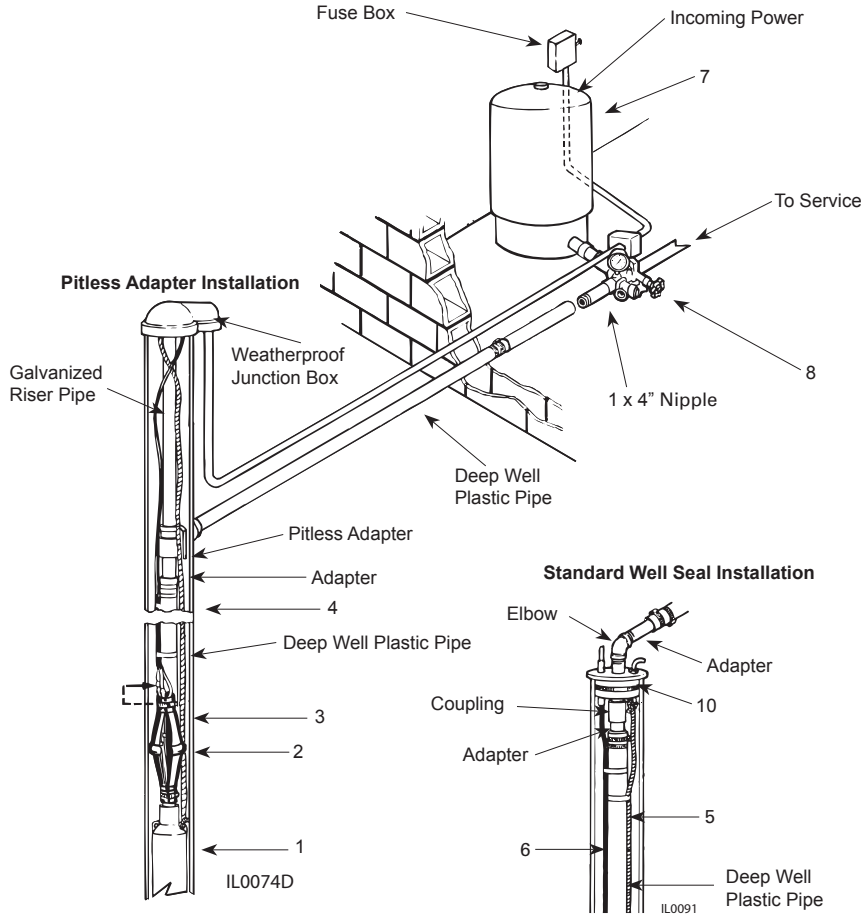
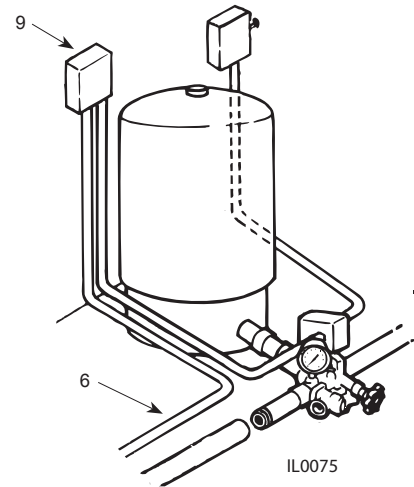

Figure 1 — Two Wire Submersible Electrical Hook-Up



1. Submersible Pump
2. Torque Arrestor
3. Splice Kit
4. Cable Guard
5. Safety Rope
6. Submersible Power Cable
7. Contained Air Tank
8. Fitting Package
9. Control Box
10. Well Seal

Figure 2 — Three Wire Submersible Electrical Hook-Up

CABLE SELECTION Chart A								
Maximum Cable Length (Motor to Service Entrance)								
115/230 Volt, 1 Phase					230 Volt, 3 Phase, 3 Wire			
Cable Selection (Copper Wire Size) AWG / 60°C Insulation					Cable Selection (Copper Wire Size) AWG / 60°C Insulation			
Volts	HP	14	12	10	8	6	4	2
115	1/2	100	160	250	390	620	960	1460
230	1/2	400	650	1020				
230	3/4	300	480	760	1200			
230	1	250	400	630	990	1540		
230	1-1/2	190	310	480	770	1200		
230	2	150	250	390	620	970	1530	
230	3	120*	190	300	470	750	1190	
230	5	--	--	180*	280	450	710	1110
CAUTION Use of wire size smaller than listed will void warranty. Lengths marked * meet the U.S. National Electrical Code ampacity only for individual conductor 60°C cable. Lengths without * meet the code for individual conductor or jacketed 60°C cable.								
460 Volt, 3 Phase, 3 Wire								
Cable Selection (Copper Wire Size) AWG / 60°C Insulation								
Volts	HP	14	12	10	8	6	4	
460	1-1/2	1700						
460	2	1300						
460	3	1000	1600					
460	5	590	950	1500				

READ THESE INSTRUCTIONS CAREFULLY BEFORE INSTALLATION

PUMP INSPECTION

1. Prior to installation check the pump for shipment damage.
2. The entire submersible pump has been factory tested. However, prior to installation check for free rotation by removing the suction screen and rotating the pump shaft coupling with fingers or a standard screwdriver. If shaft rotates (a slight drag is permissible) replace the screen.

MAJOR COMPONENTS

(See Figures 1 & 2)

Submersible Pump

1. A submersible pump is a multi-stage centrifugal. Each stage consists of an impeller and diffuser. Water pressure increases in equal amounts as it passes from stage to stage. The more stages, the higher the pressure the pump will develop.
2. Pumps are available with 2-wire or 3-wire motors. 3-wire motors require a control box sized to the same horsepower and voltage rating of the motor. 2-wire motors do not require a control box.
3. To correctly select a pump for each specific application, the following information must be known.
 - The amount of water required.
 - The inside well diameter.
 - Capacity of the well in GPM.
 - Pumping water level.
4. The well driller or pump installer will provide this information. If the well capacity is great enough select the pump to meet water requirements for now and also the future.

Control Box

1. Single phase, 3-wire, submersible motors require the use of above ground control boxes for starting. Operation of these motors without control boxes or with incorrect boxes can result in failure of motors which will void the warranty.

The Well

1. This pump is not warranted against wear from sand or other materials in the liquid being pumped.
2. Do not use this pump to develop the well. This should be done with a separate pump used only for that purpose.
3. The well should be straight so that damage during installation does not occur to the pump or motor by becoming lodged in a crooked well casing.
4. The well casing must be 4" inside diameter or greater.
5. The complete pump and motor should be submerged at least ten feet below the drawdown level of the well, but the motor should be a minimum of ten feet from top of well screen.



Figure 3

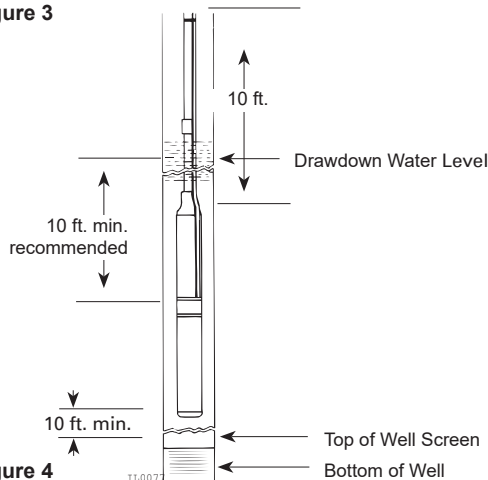

Figure 4

Piping

1. This pump can be installed with galvanized piping up to any depth. Heavy duty 160 PSI polyethylene piping and schedule 80 PVC pipe can be used for depths up to 500'.
2. The pipe size should be 1" on 5 GPM thru 10 GPM pump series and 1-1/4" on 19 GPM and 27 GPM units. Use of pipe smaller than this will result in additional pressure losses and reduced capacity.
3. Generally piping from the well to the house should be the same diameter as stated above. For long offset runs, consult friction loss tables for correct pipe sizing.

Check Valve

1. A check valve is factory installed in the discharge head of 5 thru 27 GPM submersible pumps. This maintains water within the pipe when the pump is not operating.
2. It is recommended that an additional line check valve be installed within 25 feet of the pump and below the draw down level of the water supply.
3. For well depths exceeding 200 feet, it is suggested that an additional check valve be installed every 125 feet.
4. An additional check valve should be installed in the horizontal line between the well top and the pressure tank (See Figure 13.) **CAUTION** Make certain that the check valve is pointing in the right direction with arrow pointing toward tank.

Torque Arrestor

1. On installations where rigid PVC or flexible plastic pipe is used, a torque arrestor is required. The starting torque of the motor can cause the motor to rub against the inside walls of the well casing.

Safety Rope

1. A safety rope eyelet is provided at the discharge of the pump to attach nylon safety rope. This will assist in the removal of the pump and also prevent loss of the unit in the bottom of the well due to a loose fitting or pipe deterioration.

Pressure Tank

1. The purpose of a pressure tank is to allow a certain amount of water to be drawn before the pressure drops enough to cause the pump to start. Without a pressure tank, the pump would start and stop constantly, every time water is drawn.
2. There are two types of tanks:
 - a. Standard pressure tank with air volume control or
 - b. A contained air pressure tank.

Submersible Cable

1. Submersible pump cable is not ordinary cable, but is specifically made to withstand complete submersion in water for the life of the pump.
2. Selecting the proper cable size is important. Undersized cable results in too low of voltage supply to the pump motor and ultimate motor failure. Oversized cable is costly and not necessary. Refer to chart (A) for proper cable selection.
3. Cable is selected for the maximum pump setting plus the offset distance to the service entrance (main fuse box from meter). This size is for the complete length of wire.
4. Select 3-wire cable for 3-wire motors and 2-wire cable for 2-wire motors.

Cable Guards

1. Cable guards protect submersible cable by preventing abrasion against sides of well. Install one 15 ft. above the pump and one every 25 ft. thereafter when using flexible plastic pipe.

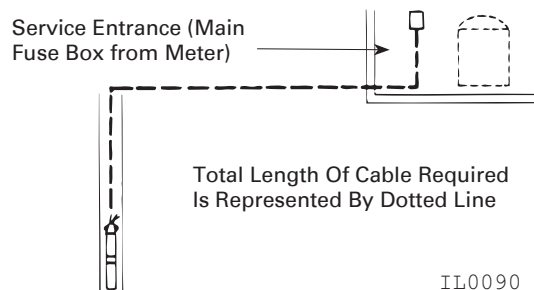

Figure 5

IL0090

SUBMERSIBLE PUMP INSTALLATION (continued)

Pressure Switch

- The pressure switch provides for automatic operation. The pump starts when the pressure drops to the switch cut-in setting and stops when the pressure reaches the switch cut-out setting.

▲ IMPORTANT The pressure switch must be installed as close to the tank as possible.

Relief Valve

- A properly sized relief valve set at 75 PSI that will pass the pumps capacity should be installed between the tank and the pressure switch. Manually activate the valve monthly to keep it in good working order. The relief valve drain port should be piped to a drain.

▲ WARNING Not providing a relief valve can cause extreme overpressure which could result in personal and/or property damage.

PUMP INSTALLATION

- The following installation instructions as shown use 160 PSI plastic pipe. Schedule 80 PVC pipe or galvanized pipe may also be used. If either of these two types are used, a foot clamp will be required to hold the PVC or galvanized pipe while connecting the next length of pipe.
- Lay the pump a foot or two from the well, pointing outward (pump discharge away from the well).
- Lay out plastic pipe, safety rope, hose clamps, bleeder orifice, piping, assembly package, tape, submersible cable, etc.
- Assembly of all components that go into the well should be made horizontally on the ground, and then lowered into the well. (See pump installation Figures 1, 2 & 14)
- Install a plastic pipe adapter in the pump discharge tapping, using teflon tape.

▲ CAUTION Do not use pipe wrench on any part of pump except the cast discharge of the pump.
- Unroll plastic pipe in a straight line.

▲ CAUTION Be sure working surface is smooth to avoid damage to the plastic pipe and electric cable. Cut off sealed end of plastic pipe with a hacksaw.
- Slide torque arrestor on plastic pipe about 10" from pump end. Pull the motor lead cable through one of the small outside holes in the torque arrestor.
- Position two hose clamps over end of the plastic pipe. Slide plastic pipe over the pipe adapter all the way to the shoulder. Position the clamp tightening screws opposite each other and away from the motor lead wires to prevent insulation damage. Tighten the hose clamps and tape clamp tab ends to pipe with plastic tape.

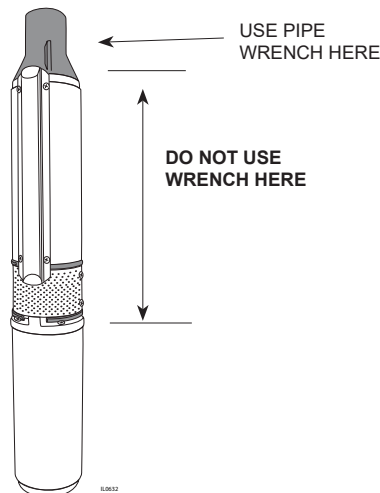

Figure 6

- Slide torque arrestor down to about 6" from the end of the plastic pipe, and clamp sufficiently to prevent the torque arrestor from sliding up on the pipe while lowering unit in well.
- Splice the electric cable to the pump leads. Heat shrink tubing and Stakon connectors are recommended. It is necessary that the splice be water tight.
- Unroll the electric cable along side of the plastic pipe. Be sure not to damage wire insulation, and that all kinks are straightened out.
- Cut the plastic pipe to proper length.

- Slide cable guards over plastic pipe and submersible cable. One at 15 ft. above the pump and one every 25 ft. thereafter. Secure guards in position with retaining clamps or tape.
 - On a standard pressure tank installation, assemble bleeder orifice and pipe assembly as shown (See Figure 7).
 - On captive air tank installation, assemble as illustrated (See Figure 8).
- Attach assembly used to plastic pipe with two stainless steel hose clamps. Tighten clamps securely.

▲ CAUTION Be sure to assemble the elbow on the pipe above the well seal. This will prevent dropping of the pump and piping into the well as you lower it.
- Tape electric cable to pipe about every five feet. Use only 1-1/2 to 2 wraps of tape, so as to allow for some movement of the cable. Tape spliced connections to pipe to eliminate rubbing against well casing. Leave four to five feet of slack, at the upper end to allow for plastic pipe stretch.
- Tie safety rope, through eyelet on top of pump. Tape end of rope to prevent unraveling. Tape safety rope to pipe every 20 feet. Do not leave any slack in rope. Tie securely on bottom side of well seal or pitless adapter and tape end of rope.

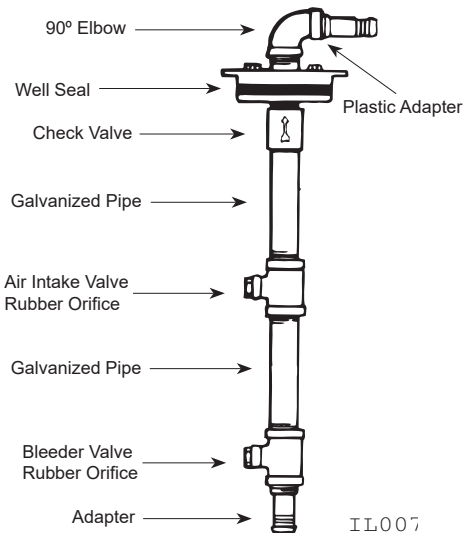

Figure 7

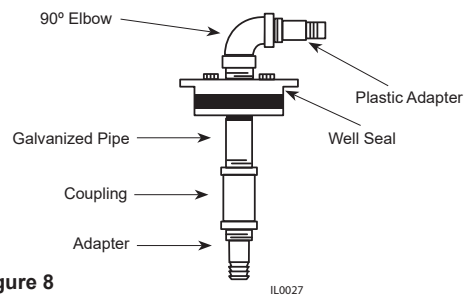

Figure 8

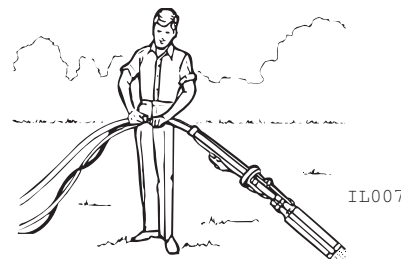

Figure 9

SUBMERSIBLE PUMP INSTALLATION (continued)

LOWERING PUMP INTO THE WELL

CAUTION Never support the weight of pump and piping by the electric cable, as this weight will break the cable connections.

1. The pump is now ready to be lowered into the well. A helper will be needed to handle the other end of the assembly. With the plastic pipe and wire cable assembly over your shoulder, lift the pump, being very careful not to kink the plastic pipe.
2. Guide the pump and piping into the well. Protect the cable when lowering to prevent scraping or damage by the edge of the well casing.
3. The helper brings his end of the assembly forward as needed. Keep the pipe, cable, and rope free of grass or other foreign matter.
4. When the entire assembly is in the well, make sure well seal is seated. Tighten the four bolts in well seal evenly.

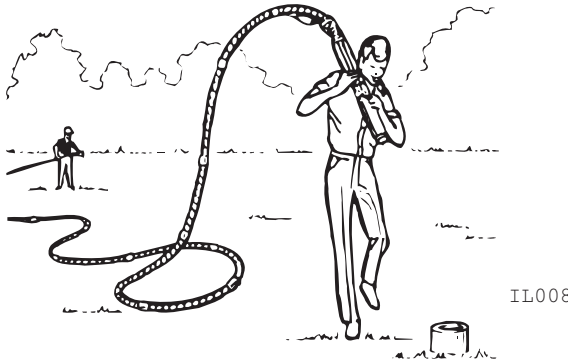

Figure 10

TANK INSTALLATION

1. The tank installation will be one of two types:
 - a. Standard pressure tank with air volume control or
 - b. A contained air pressure tank.

Standard Tank System With Air Volume Control

(See Figure 11)

1. In this type of system air is introduced to compensate for that which is absorbed by the water. Each time the pump stops, water bleeds out the small holes in bleeder orifices, leaving a quantity of air in the pipe above the lower bleeder orifice. When the pump starts again, this air is forced into the pressure tank. The air volume control releases any excess air to maintain a constant balance of water and compressed air in the tank.

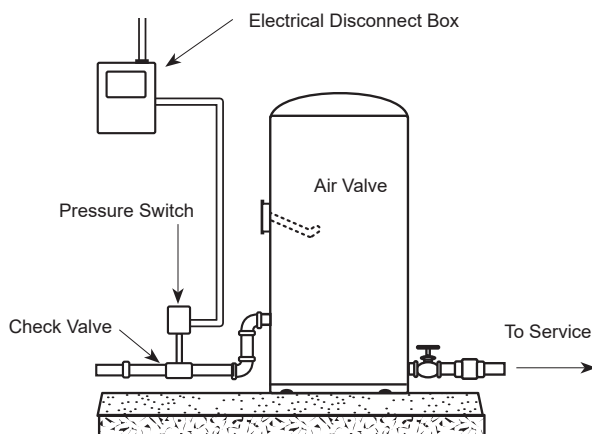

Figure 11

Contained Air Tank System

(See Figures 12 & 13)

1. In this type of system, a flexible diaphragm or bladder separates the air and water areas of the tank. The air chamber is factory precharged by means of a tire valve with pressure 2 PSI less than the cut-on pressure of the pump. Because the air is not in contact with the water, it cannot be absorbed by the water. Therefore, the original charge of air is never lost.

2. In contained air systems, none of the fittings for air introduction or air level control are required.
3. The piping in the well is also different for the two systems. The captive air tank system does not require bleeder orifice assemblies, which simplifies the installation.
4. Illustrations of the two piping systems in the well are shown (Figure 14).

PITLESS ADAPTERS

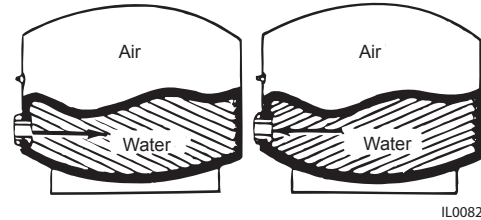

Figure 12

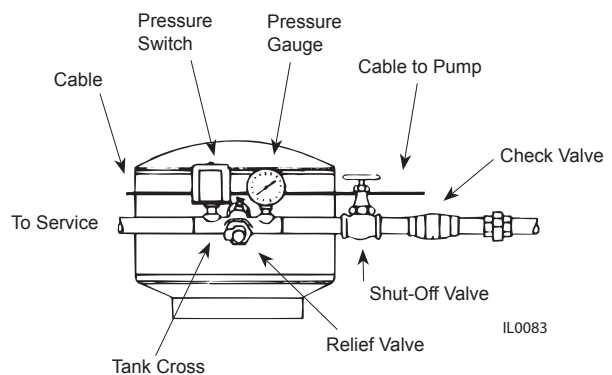

Figure 13

(See Figure 15)

1. In this installation the connection to the system supply line is made below ground by means of a pitless adapter. All piping is connected to the adapter much the same as the well seal method. It is lowered into place by a pipe extension. This makes a sanitary below ground freeze proof connection.
2. Piping from the well to the house is accomplished by installing the correct length of 160 P.S.I. plastic pipe and the appropriate fittings.

ELECTRICAL HOOK-UP

Two Wire Motor Wiring Connections

1. Simply run regular power line from electrical disconnect box to pressure switch and submersible electrical cable from pressure switch to the motor (See Figure 16).
2. To provide a suitable ground, a separate ground wire (green or bare) is required. It is connected from the disconnect box to the pressure switch and then to the ground wire of the submersible motor lead.

SUBMERSIBLE PUMP INSTALLATION (continued)

Three Wire Motor Wiring Connections

Installation with Standard Tank Installation with Contained Air Tank

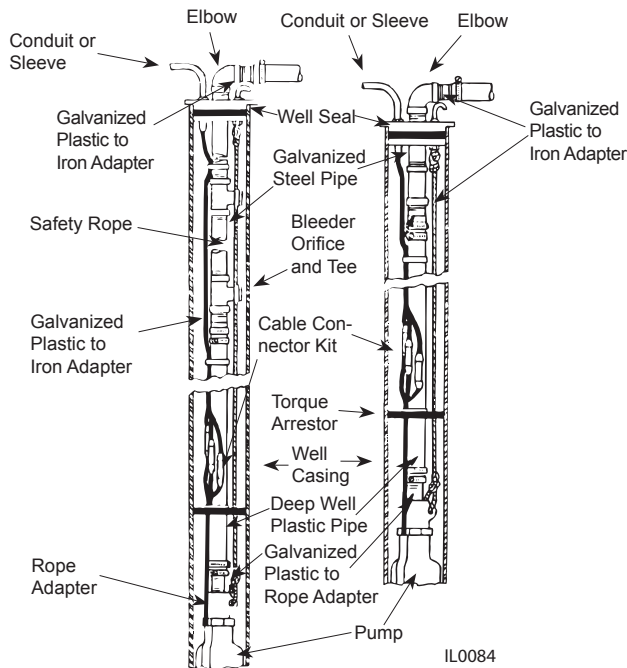

Figure 14

Pitless Adapter Installation

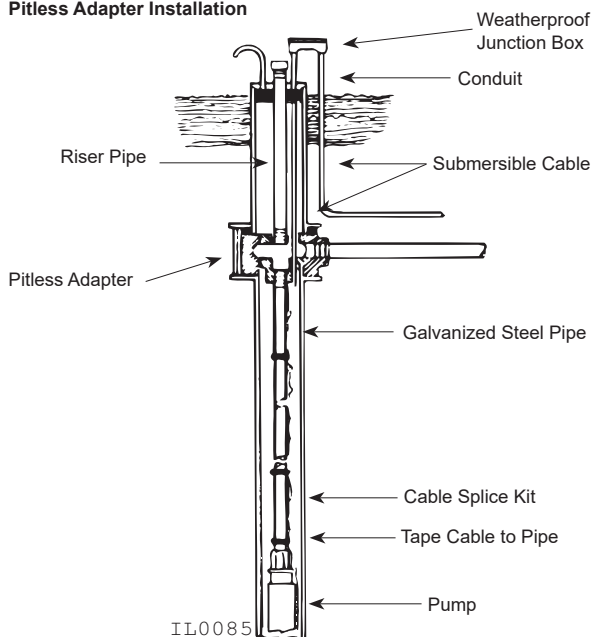

Figure 15 — Pitless Adapter Installation

1. Run submersible cable from pump to control box and connect according to color code. Two lines are connected to L1 and L2 of control box and attached to the load terminals of the pressure switch. Power line is run from electrical disconnect box and connected to the line terminals of the pressure switch (See Figure 17).
2. To provide a suitable ground, a separate ground wire (green or bare) is required. It is connected from the electrical disconnect box to the pressure switch, to the control box and then to the green ground wire of the submersible motor lead.

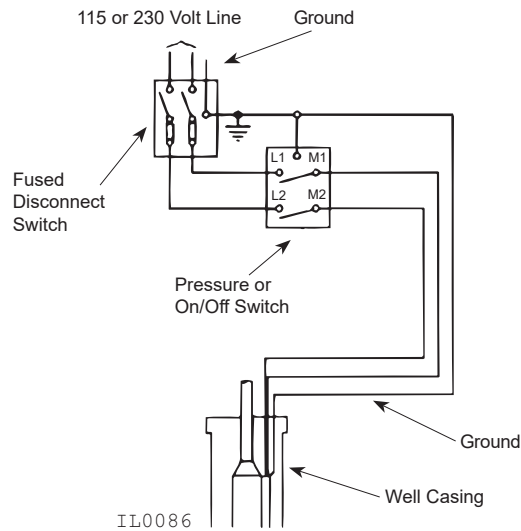

Figure 16 — 2-Wire Hook-Up

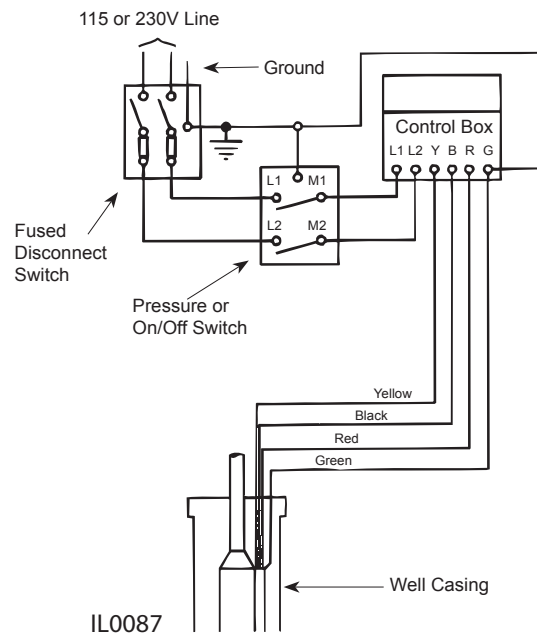

Figure 17 — 3-Wire Quick Disconnect Box

NOTE: All wiring should conform to National and Local Electrical Codes.

CAUTION Always disconnect power source before working on or near motor, its connected load or control box and wiring. If the power disconnect point is out of sight, lock in the open position and tag to prevent unexpected application of power.

FUSE SIZES

1. For proper sizing of fuses for fuse disconnect box, see Charts B, C and D. Improperly sized fuses will result in fuses blown or circuit breakers tripped.

SUBMERSIBLE PUMP INSTALLATION (continued)

GROUNDING

Proper Grounding of Submersible Motors

1. The purpose of grounding any electrical apparatus is to prevent an electrical shock hazard if exposed metal becomes connected to an electrical circuit. This can occur from a defect in construction of the electrical equipment, physical damage, or a breakdown in the insulation of the equipment. Grounding prevents shock hazard by keeping exposed metal from reaching a voltage level which could endanger anyone coming in contact with the electrical equipment. Fault current is "drained" by the ground conductor, and if the fault is severe enough, the circuit will be opened by the fuse or circuit breaker.

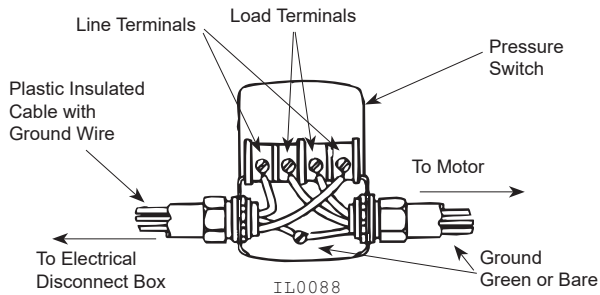

Figure 18 — Pressure Switch

2. Section 250-43 item (K) of the U.S. National Electrical Code (NEC) requires that motor-operated water pumps, including the submersible type regardless of voltage, shall be grounded. Section 26-954 of the Canadian Electrical Code specifically discusses grounding requirements for submersible pumps. Interpretation of these and other codes may vary in different states and localities, but all applicable national, state, and local codes should always be followed.

3. Any submersible motor which is to be run tested out of the well should be grounded to prevent possible shock hazard during the test.

NOTE: Always disconnect all power when making ohmmeter check and while pulling or installing a pump.

4. The most logical way to "frame" ground a submersible motor is normally as follows:
 - a. Run an extra wire with the motor power conductors. This wire must be sized to meet Table 250-95 in the U.S. National Electrical Code. If code information is unavailable, using the same size wire as the power conductors is normally adequate.
 - b. The ground wire may be insulated or bare. If insulated, it must be green with or without yellow stripe(s). The ground wire may be part of, or separate from the supply cable. It may be continuous or spliced above the pump along with the supply cable.
 - c. Connect the green or bare ground wire to the green ground wire of the submersible motor lead wire assembly. If the lead wire assembly does not include a separate ground wire. Attach a lug to the ground wire and place the lug over one of the motor studs above the pump intake flange so the pump will not be cocked. The ground lug will then be secured with the nut which holds the pump on the motor.
 - d. Connect the other end of ground wire to the power supply grounding terminal or to the control panel ground bar if it is connected to the power supply ground.
 - e. All connections should be tight and corrosion resistant. Screws, lugs or clamps should be made of corrosion resistant material.

Grounding Control Boxes

1. It is recommended the control box grounding terminal always be connected to circuits which include a grounding conductor. In fact, this is a requirement of the National Electrical Code. If the circuit has no grounding conductor and no metal conduit from the box to supply panel, use a wire at least as large as line conductors and connect from supply panel to the control box and to the motor lead ground wire.

▲ WARNING Failure to ground the box frame can result in a fatal electrical shock hazard if a circuit fault occurs.

▲ WARNING Serious or fatal electrical shock may result from failure to connect all metal plumbing, and the motor if outside a drilled well, to the power supply grounding terminal with wire no smaller than motor cable wires. Do not use motor in swimming areas.

Grounding Lightning Arrestors In Control Boxes

1. When the box has a lightning arrestor, it must be grounded, metal to metal, all the way to the water strata for the lightning arrestor to be effective. Grounding the arrestor to a driven ground rod provides little or no protection for the motor.

SUBMERSIBLE MOTOR COOLING

1. When the pump is set below any screen openings or below the bottom of the casing a top feeding well condition can exist which reduces the rate of cooling water flow past the motor.
2. If the flow rate is less than specified a flow inducer sleeve or an alternate method of increasing water velocity past the motor must be used for proper cooling.

Flow Inducer Sleeve

1. A flow inducer sleeve is a tube over the motor, closed off above the pump intake and extended to the bottom of the motor or lower. The sleeve material is corrosion resistant metal or heavy plastic.
2. A flow inducer sleeve should always be used when the pump is in an open body of water. Make sure that such an installation is grounded.

▲ CAUTION When inherent overheating protection is not provided use with approved motor control that matches motor input in full load amperes with overload elements selected or adjusted in accordance with control instructions.

▲ CAUTION When inherent overheating protection is provided use with approved control that matches motor input in full load amperes.

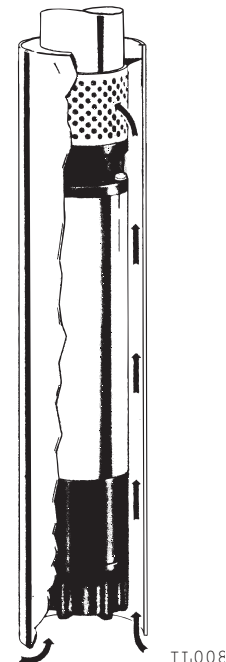

Figure 19

TROUBLESHOOTING CHART	
Symptom	Possible Cause(s)
Motor does not start	<ol style="list-style-type: none"> 1. Blown fuse/tripped breaker 2. Inadequate power supply 3. Faulty pressure switch 4. Faulty cable or motor 5. Faulty control box parts 6. Loose wiring or connections 7. Bound pump
Motor starts too often	<ol style="list-style-type: none"> 1. Waterlogged Tank 2. Pressure switch setting 3. Stuck open check valve 4. Leak in system
Motor runs continuously	<ol style="list-style-type: none"> 1. Faulty pressure switch 2. Leak in system 3. Check valve stuck closed 4. Low level well 5. Loose/broken motor/pump shaft 6. Worn pump 7. Blocked screen
Motor runs but overload protector trips	<ol style="list-style-type: none"> 1. Control box location too hot 2. Faulty cable or motor 3. Faulty control box parts 4. Incorrect voltage 5. Worn pump or motor

SUBMERSIBLE PUMP SPECIFICATIONS

TWO WIRE SPECIFICATIONS					Chart B
HP	Volts	Maximum Amps	Line to Line Resistance	Locked Rotor Amps	Dual Element Fuse Size
1/2	115	12.0	1.0 - 1.3	64.4	15
1/2	230	6.0	4.2 - 5.2	32.2	7
3/4	230	8.0	3.0 - 3.6	40.7	9
1	230	10.4	2.2 - 2.7	48.7	12
1-1/2	230	13.1	1.5 - 1.9	66.6	15

THREE WIRE SINGLE PHASE SPECIFICATIONS						Chart C
HP	Volts	Maximum Amps	Line to Line Resistance	Locked Rotor Amps	Dual Element Fuse Size	
1/2	115	Y - 12.0 B - 12.0 R - 0.0	M 1.0 - 1.3 S 4.1 - 5.1	50.5	15	
1/2	230	Y - 6.0 B - 6.0 R - 0.0	M 4.2 - 5.2 S 16.7 - 20.5	23.0	7	
3/4	230	Y - 8.0 B - 8.0 R - 0.0	M 3.0 - 3.6 S 11.0 - 13.4	34.2	9	
1	230	Y - 10.4 B - 10.4 R - 0.0	M 2.2 - 2.7 S 9.9 - 12.1	41.8	12	
1-1/2	230	Y - 11.5 B - 11.0 R - 1.3	M 1.5 - 2.3 S 6.2 - 12.0	52.0	15	
2	230	Y - 13.2 B - 11.9 R - 2.6	M 1.6 - 2.3 S 5.2 - 7.1	51.0	15	
3	230	Y - 17.0 B - 12.6 R - 6.0	M 0.9 - 1.5 S 3.0 - 4.9	83.5	2	
5	230	Y - 27.5 B - 19.1 R - 10.8	M .68 - 1.0 S 1.8 - 2.8	121.0	30	
Main (M) winding resistance: Yellow - Black Start (S) winding resistance: Yellow - Red						

FOUR INCH THREE PHASE SPECIFICATIONS					Chart D
HP	Volts	Maximum Amps	Line to Line Resistance	Locked Rotor Amps	Dual Element Fuse Size
1-1/2	230	5.9	3.2 - 4.0	33.1	7
1-1/2	460	3.0	13.0 - 16.0	16.6	4
2	230	8.1	2.4 - 3.0	46.6	10
2	460	4.1	9.7 - 12.0	23.3	5
3	230	10.9	1.8 - 2.2	62.0	12
3	460	5.5	7.0 - 8.7	31.0	6
5	230	17.8	.9 - 1.0	106.0	20
5	460	8.9	3.6 - 4.4	53.0	10
7-1/2	230	26.4	.6 - .8	164.0	30
7-1/2	460	13.2	2.4 - 3.4	82.0	15
10	460	18.8	1.8 - 2.3	116.0	25

NOTES

ZOELLER
PUMP COMPANY



MAIL TO: P.O. BOX 16347 • Louisville, KY 40256-0347
SHIP TO: 3649 Cane Run Road • Louisville, KY 40211-1961
Tel: (502) 778-2731 • 1 (800) 928-PUMP

Trusted. Tested. Tough.®

Visit our website:
zoellerpumps.com