

Patent No. 8,535,014  
 Automatic model only



MAIL TO: P.O. BOX 16347 • Louisville, KY 40256-0347  
 SHIP TO: 3649 Cane Run Road • Louisville, KY 40211-1961  
 Tel: (502) 778-2731 • 1 (800) 928-PUMP

Visit our website:  
 zoellerpumps.com

Product information presented here reflects conditions at time of publication. Consult factory regarding discrepancies or inconsistencies.

# TECHNICAL DATA SHEET

## EXPLOSION PROOF OR DUST-IGNITION PROOF RATED SERIES

Models X4186, X4188 and X4189 Submersible Effluent Pumps for Hazardous Locations

Class I, Division 1, Groups C & D Rated and Class I, Zone 1, Groups IIA & IIB Gas Areas

OR

Class II, Division 1, Groups E, F & G and Zone 20 Dust Areas

### PRODUCT SPECIFICATIONS

<b>MOTOR</b>	Horse Power	1-1/2 - 2 HP
	Voltage	200 - 460
	Phase	3 Ph
	Hertz	60 Hz
	RPM	3450
	Insulation	Class F
	Amps	4.6 - 20.5
<b>PUMP</b>	Operation	Automatic or Nonautomatic
	Auto On/Off Points	19-1/2" (495 mm) / 9.75" (248 mm)
	Discharge Size	1-1/2" NPT*
	Solids Handling	3/4" (19 mm)
	Cord Length	25' (7.6 m), Optional 50' (15.2 m)
	Cord Type	UL listed 8-wire (3 Ph) SOOW
	Max. Head	114' (34.7 m)
	Max. Flow Rate	145 GPM (549 LPM)
	Max. Operating Temp.	104 °F (40 °C)
	Cooling	Oil filled
	Motor Protection	Thermal sensor
<b>MATERIALS</b>	Upper Bearing	Ball bearing
	Lower Bearing	Ball bearing
	Mechanical Seals	Carbon and ceramic with stainless steel parts
	Impeller Type	Non-clogging vortex
	Impeller	Cast Iron
	Hardware	Stainless steel or brass
	Motor Shaft	416 stainless steel
	Gasket	Neoprene square rings

### AUTOMATIC

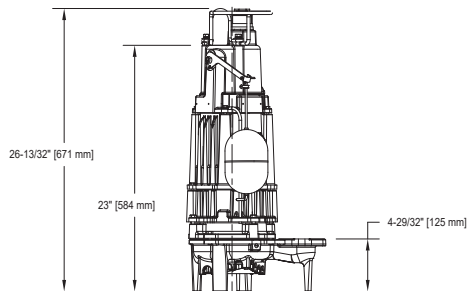
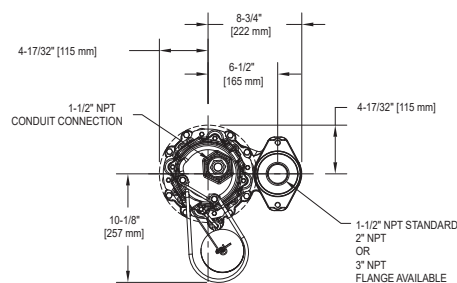

SK3449

### NONAUTOMATIC

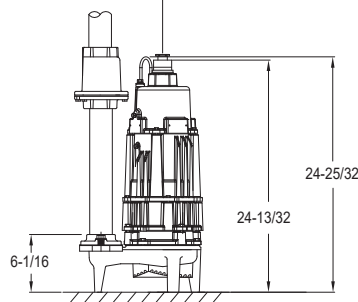
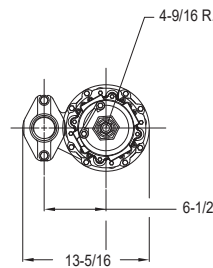

All Class 30 cast iron construction.

NOTE: The sizing of effluent systems normally requires variable level float(s) controls and properly sized basins to achieve required pumping cycles or dosing timers with nonautomatic pumps.

NOTE: Pump tags will be specific to either gas or dust areas

\* Optional discharge flanges available:

- 10-1305 - 2"
- 10-1306 - 3"



SK1992

# TOTAL DYNAMIC HEAD FLOW PER MINUTE

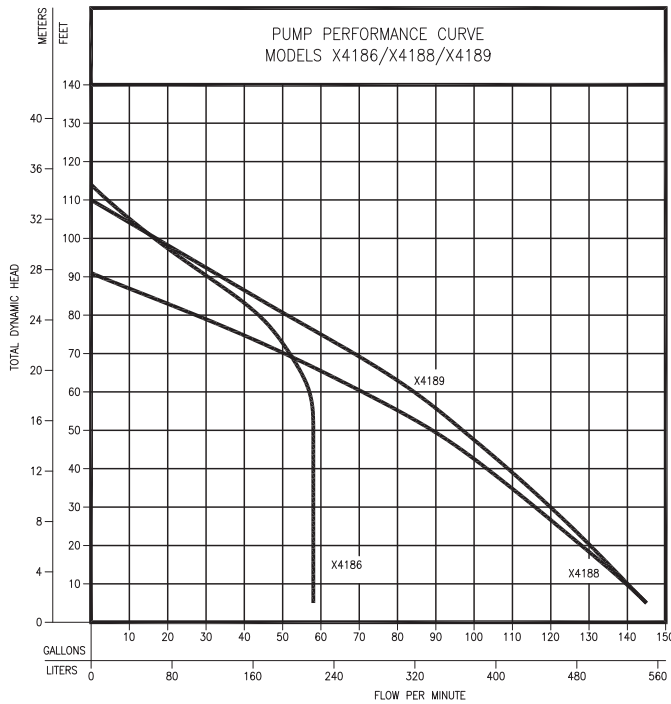

TOTAL DYNAMIC HEAD/FLOW  
PER MINUTE  
EFFLUENT AND DEWATERING

MODELS		X4186		X4188		X4189	
Feet	Meters	Gal.	Liters	Gal.	Liters	Gal.	Liters
5	1.5	58	220	145	549	145	549
10	3.0	58	220	140	530	140	530
20	6.1	58	220	128	484	130.5	494
30	9.1	58	220	116	439	120	454
40	12.2	58	220	103.5	392	109	413
50	15.2	58	220	90	341	97	367
60	18.3	58	220	71	269	85	322
70	21.3	52	197	51	193	69	261
80	24.4	45	170	28	106	51	193
90	27.4	30.5	115	2	8	34	129
100	30.5	16	60	---	---	17	64
110	32	4	15	---	---	---	---
120	36.6	---	---	---	---	---	---
130	39.6	---	---	---	---	---	---
Shut-off Head		114 ft. (35m)		91 ft. (28m)		110 ft. (34m)	

009903

Model	MODEL COMPARISON							
	*Mode	Volts	Ph	Amps	HP	Hz	Lbs	Kg
DX4186	Auto	230	1	13.7	1-1/2	60	128	58
EX4186	Non	230	1	13.7	1-1/2	60	126	57
HX4186	Auto	200	1	17.2	1-1/2	60	128	58
IX4186	Non	200	1	17.2	1-1/2	60	126	57
FX4186	Non	230	3	9.2	1-1/2	60	126	57
JX4186	Non	200	3	10.3	1-1/2	60	126	57
GX4186	Non	460	3	4.6	1-1/2	60	126	57
DX4188	Auto	230	1	14.0	1-1/2	60	128	58
EX4188	Non	230	1	14.0	1-1/2	60	126	57
HX4188	Auto	200	1	16.8	1-1/2	60	128	58
IX4188	Non	200	1	16.8	1-1/2	60	126	57
FX4188	Non	230	3	8.9	1-1/2	60	126	57
JX4188	Non	200	3	10.3	1-1/2	60	126	57
GX4188	Non	460	3	4.3	1-1/2	60	126	57
DX4189	Auto	230	1	17.1	2	60	128	58
EX4189	Non	230	1	17.1	2	60	126	57
HX4189	Auto	200	1	20.5	2	60	128	58
IX4189	Non	200	1	20.5	2	60	126	57
FX4189	Non	230	3	11.2	2	60	126	57
JX4189	Non	200	3	13.2	2	60	126	57
GX4189	Non	460	3	6.0	2	60	126	57

\*For non-auto models, water level switch is required to be set at a minimal off point of 10 inches to meet dust-ignition proof certification requirements.  
All Models are, cCSAus certified for hazardous gas or dust locations.  
Tested to FM Standards 3600 & 3615 & 3616 by CSA

## NOTE:

1. See FM3459 for correct intrinsically-safe simplex or duplex panel
2. See FM0526 for variable level control switches rated 30VDC are used as a control activator. Quantity required dependent upon panel selection.



All installation of controls, protection devices and wiring should be done by a qualified licensed electrician. All electrical and safety codes should be followed including the most recent National Electrical Code (NEC) and the Occupational Safety and Health Act (OSHA).