

Trusted. Tested. Tough.®



SECTION:2.30.010
 FM3516
 0824
 Supersedes
 New

Patent No. 8,535,014
 Automatic model only

MAIL TO: P.O. BOX 16347 • Louisville, KY 40256-0347
 SHIP TO: 3649 Cane Run Road • Louisville, KY 40211-1961
 Tel: (502) 778-2731 • 1 (800) 928-PUMP

Visit our website:
 zoellerpumps.com

Product information presented here reflects conditions at time of publication. Consult factory regarding discrepancies or inconsistencies.

TECHNICAL DATA SHEET

EXPLOSION PROOF OR DUST-IGNITION PROOF RATED SERIES
 Models X4161 and X4163 Submersible Effluent Pumps for Hazardous Locations
 Class I, Division 1, Groups C & D Rated and Class I, Zone 1, Groups IIA & IIB Gas Areas
 or
 Class II, Division 1, Groups E, F & G and Zone 20 Dust Areas

PRODUCT SPECIFICATIONS

MOTOR	Horse Power	1/2
	Voltage	115
	Phase	1 Ph
	Hertz	60 Hz
	RPM	3450
	Type	Permanent split capacitor
	Insulation	Class B
	Amps	15.0 - 15.5
PUMP	Operation	Automatic or nonautomatic
	Auto On/Off Points	19-1/2" (495 mm) / 9.75"(24.7 cm)
	Discharge Size	1-1/2" NPT*
	Solids Handling	3/4" (19 mm) spherical solids
	Cord Length	25' (7.6 m), Optional 50' (15.2 m)
	Cord Type	UL listed 5-wire (1 Ph)
	Max. Head	66' (20.1 m)
	Max. Flow Rate	100 GPM (379 LPM)
	Max. Operating Temp.	104 °F (40 °C)
	Cooling	Oil filled
	Motor Protection	Auto reset thermal overload (1 Ph)
MATERIALS	Upper Bearing	Ball bearing
	Lower Bearing	Ball bearing
	Mechanical Seals	Carbon and ceramic with stainless steel parts
	Impeller Type	Non-clogging vortex
	Impeller	Cast iron
	Hardware	Stainless steel
	Motor Shaft	416 stainless steel
	Gasket	Neoprene square rings

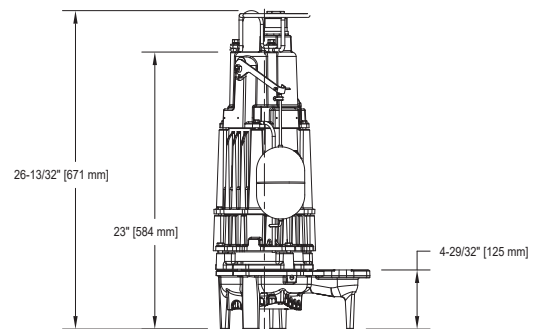
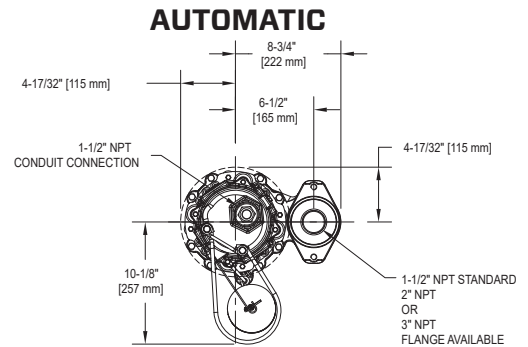

SK3449

NONAUTOMATIC

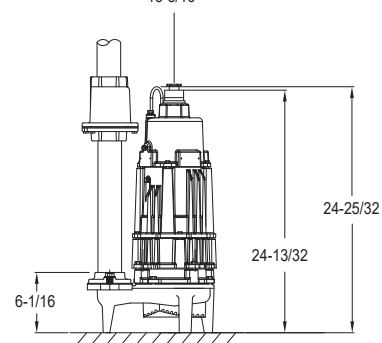
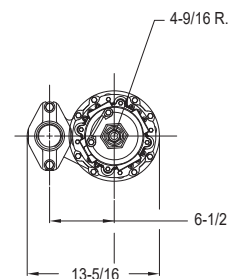

SK1992

All Class 30 cast iron construction.

NOTE: The sizing of effluent systems normally requires variable level float(s) controls and properly sized basins to achieve required pumping cycles or dosing timers with nonautomatic pumps.

NOTE: Pump tags will be specific to either gas or dust areas

* Optional discharge flanges available:

10-1305 - 2"

10-1306 - 3"



TOTAL DYNAMIC HEAD FLOW PER MINUTE

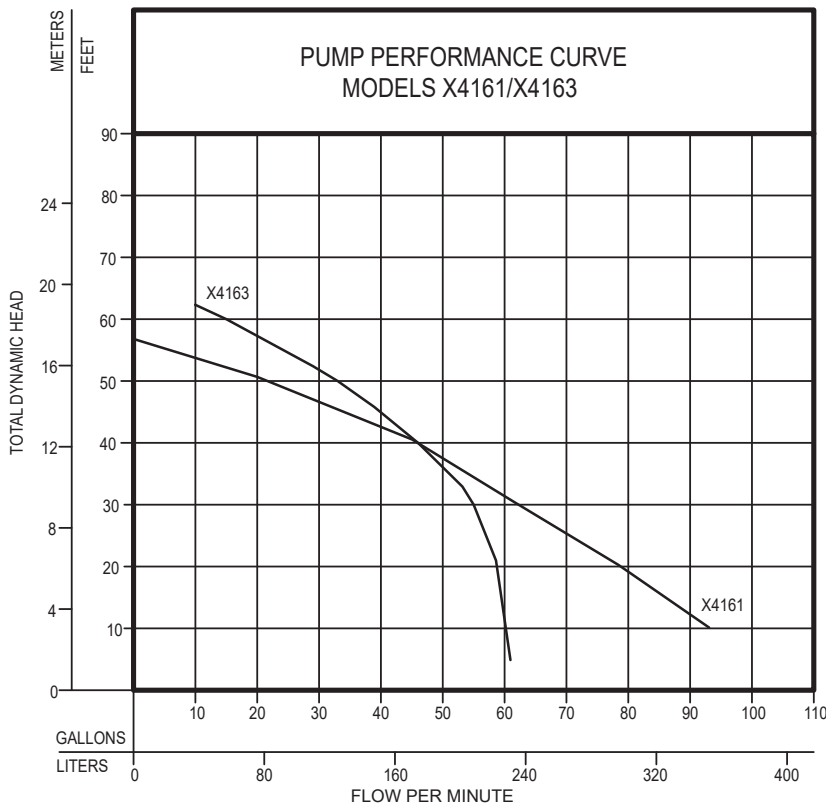

TOTAL DYNAMIC HEAD/FLOW PER MINUTE EFFLUENT AND DEWATERING

MODELS		X4161		X4163	
Feet	Meters	Gal.	Liters	Gal.	Liters
5	1.5	100	379	61	231
10	3.0	93	352	60	227
15	4.6	86	326	60	227
20	6.1	79	299	59	223
25	7.6	71	267	57	216
30	9.1	62	235	55	208
40	12.2	45	170	46	174
50	15.2	20	76	33	125
60	18.3	--	--	15	57
Shut-off Head:		56 ft. (17.1m)		66 ft. (20.1m)	

009920

Model	MODEL COMPARISON							
	*Mode	Volts	Ph	Amps	HP	Hz	Lbs	Kg
MX4161	Auto	115	1	15.5	1/2	60	123	55
NX4161	Non	115	1	15.5	1/2	60	114	51
MX4163	Auto	115	1	15.0	1/2	60	123	55
NX4163	Non	115	1	15.0	1/2	60	114	55

*For non-auto models, water level switch is required to be set at a minimal off point of 10 inches to meet dust-ignition proof certification requirements. All Models are, cCSAus certified for hazardous gas or dust locations. Tested to FM Standards 3600 & 3615 & 3616 by CSA

NOTES:

1. See FM3459 for correct intrinsically-safe simplex or duplex panel
2. See FM0526 for variable level control switches rated 30VDC are used as a control activator. Quantity required dependent upon panel selection.
3. Automatic pumps with integral float-operated mechanical switch; no external control required
4. Automatic pumps: Use the optional seal-failure panel (10-1031) to activate the moisture sensor circuit for pump protections and when required by local codes



All installation of controls, protection devices and wiring should be done by a qualified licensed electrician. All electrical and safety codes should be followed including the most recent National Electrical Code (NEC) and the Occupational Safety and Health Act (OSHA).