

Product information presented here reflects conditions at time of publication. Consult factory regarding discrepancies or inconsistencies.

Patent No. 8,535,014  
Automatic model only

## TECHNICAL DATA SHEET

EXPLOSION PROOF OR DUST-IGNITION PROOF RATED SERIES\*

Models X161, X163 and X165 Submersible Effluent Pumps for Hazardous Locations  
Class I, Division 1, Groups C & D Rated and Class I, Zone 1, Groups IIA & IIB Gas Areas

or

Class II, Division 1, Groups E, F & G and Zone 20 Dust Areas

### PRODUCT SPECIFICATIONS

<b>MOTOR</b>	Horse Power	1/2 (X161, X163) or 1 (X165)	
	Voltage	115 - 575	
	Phase	1 or 3 Ph	
	Hertz	60 Hz	
	RPM	3450	
	Type	Permanent split capacitor or 3 Ph	
	Insulation	Class B	
	Amps	2.4 - 15.5	
	<b>PUMP</b>	Operation	Automatic or nonautomatic
Auto On/Off Points		19-1/2" (495 mm) / 10" (25.4 cm)	
Discharge Size		1-1/2" NPT (optional 2" or 3" flange)	
Solids Handling		3/4" (19 mm) spherical solids	
Cord Length		20' (6 m) standard	
Cord Type		UL listed 5-wire (1 Ph) or 8-wire (3 Ph) SOOW	
Max. Head		86.5' (26 m)	
Max. Flow Rate		100 GPM (379 LPM)	
Max. Operating Temp.		104 °F (40 °C)	
Cooling		Oil filled	
Motor Protection		Auto reset thermal overload (1 Ph) or thermal sensor (3 Ph)	
<b>MATERIALS</b>		Upper Bearing	Ball bearing
		Lower Bearing	Ball bearing
	Mechanical Seals	Carbon and ceramic with stainless steel parts	
	Impeller Type	Non-clogging vortex	
	Impeller	Cast iron	
	Hardware	Stainless steel	
	Gasket	Neoprene square rings	

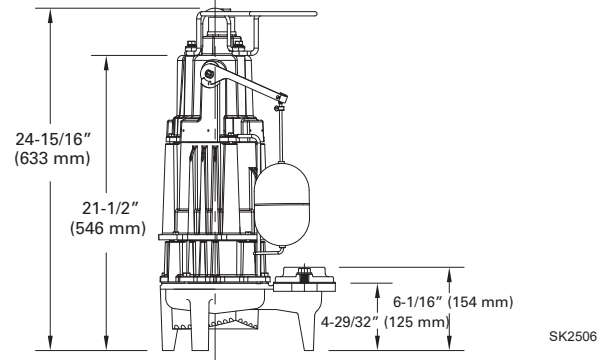
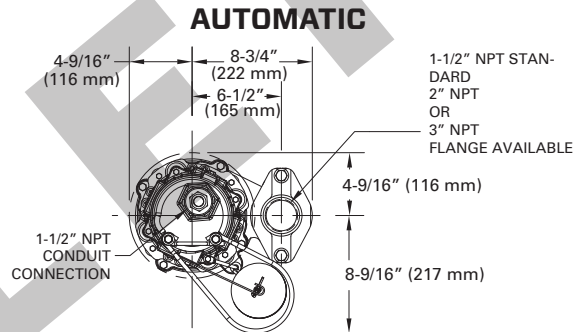

### NONAUTOMATIC

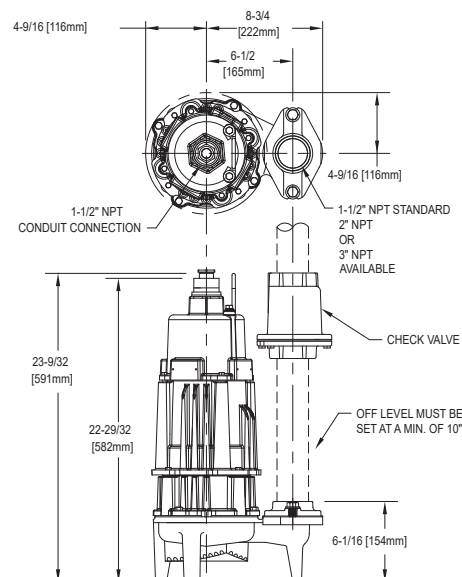

All Class 30 cast iron construction.

NOTE: The sizing of effluent systems normally requires variable level float(s) controls and properly sized basins to achieve required pumping cycles or dosing timers with nonautomatic pumps.

NOTE: \*Pump tags will be specific to either gas or dust areas



# TOTAL DYNAMIC HEAD FLOW PER MINUTE

MODELS		X161		X163		X165	
Feet	Meters	Gal.	Liters	Gal.	Liters	Gal.	Liters
5	1.5	100	379	61	231	61	231
10	3.0	93	352	60	227	60.5	229
15	4.6	86	326	60	227	60.3	228
20	6.1	79	299	59	223	60	227
25	7.6	71	267	57	216	59	223
30	9.1	62	235	55	208	58	220
40	12.2	45	170	46	174	55	208
50	15.2	20	76	33	125	50	189
60	18.3	--	--	15	57	39	148
70	21.3	--	--	--	--	22.5	85
80	24.4	--	--	--	--	10	38
Shut-off Head:		56 ft. (17.1m)		66 ft. (20.1m)		86.5 ft. (26.4m)	

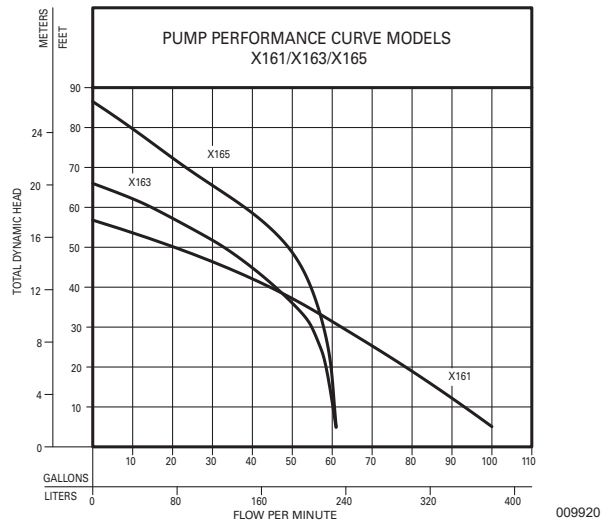

Model	MODEL COMPARISON										
	Seal	*Mode	Volts	Ph	Amps	HP	Hz	Lbs	Kg	Simplex	Duplex
MX161	Single	Auto	115	1	15.5	1/2	60	123	55	3 & 4	---
NX161	Single	Non	115	1	15.5	1/2	60	114	51	1 & 2	1 & 2
DX161	Single	Auto	230	1	7.5	1/2	60	123	55	3 & 4	---
EX161	Single	Non	230	1	7.5	1/2	60	114	51	1 & 2	1 & 2
HX161	Single	Auto	200	1	8.8	1/2	60	123	55	3 & 4	---
IX161	Single	Non	200	1	8.8	1/2	60	117	53	1 & 2	1 & 2
JX161	Single	Non	200	3	6.4	1/2	60	117	53	1 & 2	1 & 2
FX161	Single	Non	230	3	5.2	1/2	60	117	53	1 & 2	1 & 2
GX161	Single	Non	460	3	2.9	1/2	60	117	53	1 & 2	1 & 2
BAX161	Single	Non	575	3	2.4	1/2	60	117	53	1 & 2	1 & 2
MX163	Single	Auto	115	1	15.0	1/2	60	123	55	3 & 4	---
NX163	Single	Non	115	1	15.0	1/2	60	114	55	1 & 2	1 & 2
DX163	Single	Auto	230	1	7.5	1/2	60	123	55	3 & 4	---
EX163	Single	Non	230	1	7.5	1/2	60	117	53	1 & 2	1 & 2
HX163	Single	Auto	200	1	8.5	1/2	60	123	55	3 & 4	---
IX163	Single	Non	200	1	8.5	1/2	60	117	53	1 & 2	1 & 2
JX163	Single	Non	200	3	6.0	1/2	60	117	53	1 & 2	1 & 2
FX163	Single	Non	230	3	4.8	1/2	60	117	53	1 & 2	1 & 2
GX163	Single	Non	460	3	2.9	1/2	60	117	53	1 & 2	1 & 2
BAX163	Single	Non	575	3	2.4	1/2	60	117	53	1 & 2	1 & 2
DX165	Single	Auto	230	1	10.2	1	60	124	56	3 & 4	---
EX165	Single	Non	230	1	10.2	1	60	114	51	1 & 2	1 & 2
HX165	Single	Auto	200	1	12.6	1	60	124	56	3 & 4	---
IX165	Single	Non	200	1	12.6	1	60	117	53	1 & 2	1 & 2
JX165	Single	Non	200	3	7.5	1	60	117	53	1 & 2	1 & 2
FX165	Single	Non	230	3	7.4	1	60	117	53	1 & 2	1 & 2
GX165	Single	Non	460	3	3.7	1	60	117	53	1 & 2	1 & 2

\*For non-auto models, water level switch is required to be set at a minimal off point of 10 inches to meet dust-ignition proof certification requirements. Additional cord lengths are available in 25' (7.6 m), 35' (11 m) and 50' (15 m). All Models are, cCSAus certified for hazardous gas or dust locations. Tested to FM Standards 3600 & 3615 & 3616 by CSA

## SELECTION GUIDE

1. See FM1705 for correct intrinsically-safe simplex or duplex panel
2. See FM0526 for variable level control switches rated 30VDC are used as a control activator. Quantity required dependent upon panel selection.
3. Automatic pumps with integral float-operated mechanical switch; no external control required
4. Automatic pumps: Use the optional seal-failure panel (10-1031) to activate the moisture sensor circuit for pump protections and when required by local codes

**CAUTION** All installation of controls, protection devices and wiring should be done by a qualified licensed electrician. All electrical and safety codes should be followed including the most recent National Electrical Code (NEC) and the Occupational Safety and Health Act (OSHA).