

Product information presented here reflects conditions at time of publication. Consult factory regarding discrepancies or inconsistencies.

TECHNICAL DATA SHEET

Model 521 Multi-Purpose Condensate Pump Series

Automatically removes condensation from air conditioning and 90+ condensing furnaces as well as dehumidifiers, ice makers, water coolers and refrigeration systems.

PRODUCT SPECIFICATIONS

MOTOR	Horse Power	1/6
	Voltage	115
	Phase	1
PUMP	Operation	Automatic
	Discharge Size	3/8"
	Cord Length	6 ft (2m)
	Cord Type	Grounded plug
	Max. Head	22' (6.7 m)
	Max. Flow Rate	102 GPH (386 LPM)
	Max. Operating Temp.	140° F (60° C)

- Indicator lights for power (green), pump run (yellow) and high level alarm (red)
- Handles condensate up to 140° F (60° C)
- 22 ft (6.7 m) TDH
- Dimensions: 6" (15 cm) x 6" (15 cm) x 11-1/2" (29 cm) long
- 1 gallon (4 liter) capacity
- Built-in safety switch and check valve
- Will automatically shut pump down in event of failure
- 1/4" (6 mm) quick connects for safety switch and alarm
- Four inlet options

TOTAL DYNAMIC HEAD FLOW PER HOUR

Feet	Meters	Gallons	Liters
3	.9	102	386
6	1.8	90	341
9	2.7	79	299
12	3.7	66	250
15	4.6	49	185
18	5.5	23	87
Shut-off Head		22 ft. (6.7 m)	

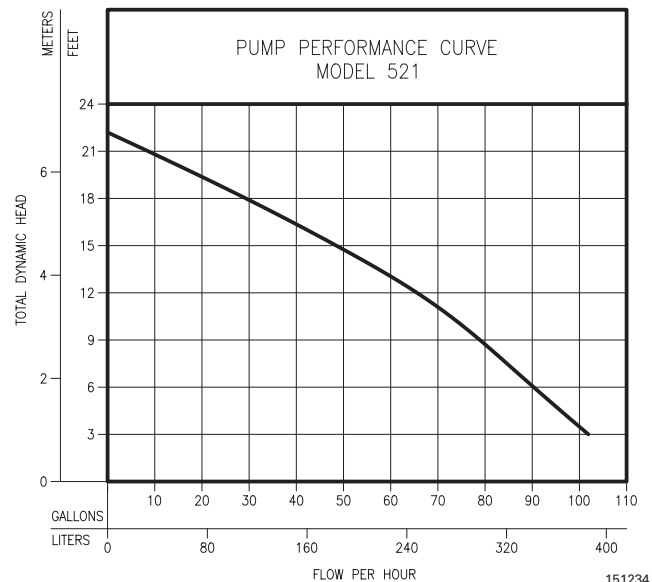
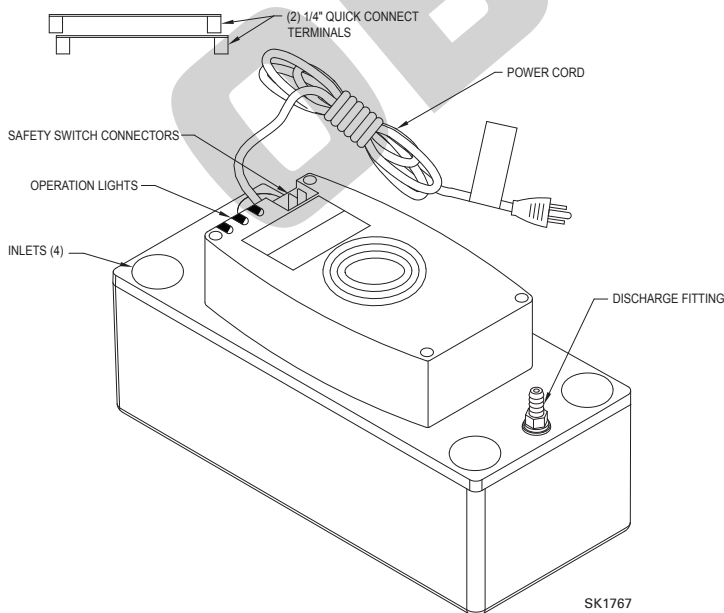

Tested to UL Standard UL778
& Certified to CSA
Standard C22.2 No. 108