

ZOELLER[®]
PUMP COMPANY
zoellerpumps.com



Trusted. Tested. Tough.[®]

Qwik Jon[®]
PREMIER



Grinder Upflush System

Add a Bathroom Anywhere! No Gravity Drain Required!
Making Bathroom Installations Easy!



Zoeller Family of Water Solutions™

Copyright Zoeller Co. All rights reserved.

Features and Benefits:

A quiet, preassembled 1/2 HP grinder pump system requiring minimal space for installation!

Install a complete bathroom without breaking concrete!

Easily connects to a tub, shower, sink, or other fixtures with 2" NPT or 1-1/2" (DN25) slip side inlets.

Tri-Slice® Cutter Technology - three independent cutting channels provide over 250,000 cuts per minute.

Install as a freestanding unit or behind a wall with the extension kit.

Automatic reset thermal overload protects the pump.

Carbon/Ceramic mechanical shaft seal for long life.

Upper and lower ball bearings for efficient and quiet operation.

Non-clogging vortex impeller for reliable operation.

Recessed side handles for carrying.

Withstands total immersion (IP68).

1" Discharge elbow with built-in check valve.

Standard 6' (1.8 m) cord with right angle plug.

Premium investment-cast 440C stainless steel cutter and cutter plate.

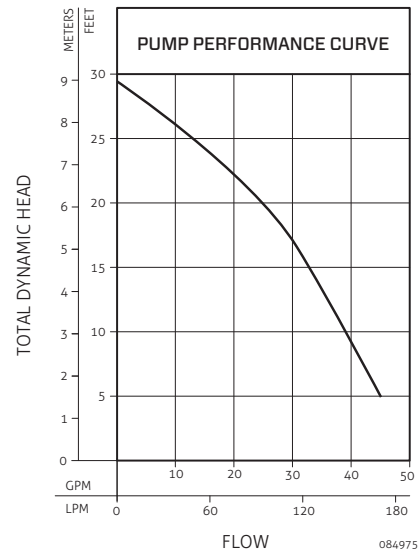
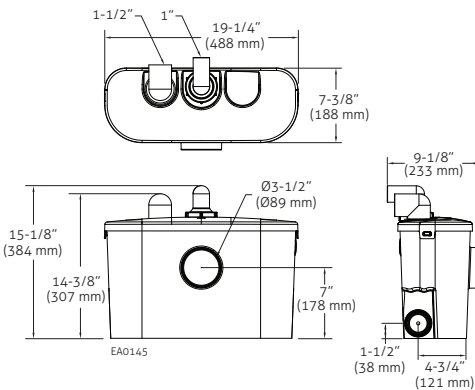
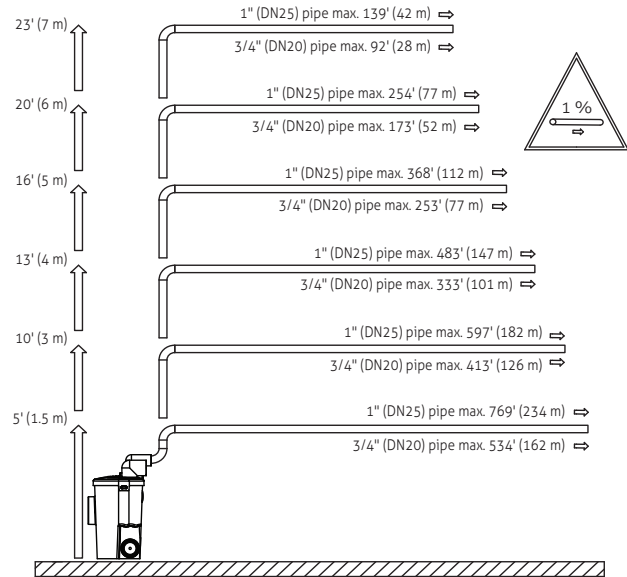

Model	Mode	Volts (V)	Ph Ø	Amps (A)	Motor		Weight	
					HP	kW (p1)	kg	lbs
201	Vertical Switch	115	1	9.6	1/2	1.0	13.5	29.8

Qwik Jon Premier Part Numbers:

Model #	Product
201-0006	Qwik Jon® Premier grinder pump and tank.
201-0021	Qwik Jon® Premier All-In-One System. QJP & Toilet, 1 box. Ships on a skid.
201-4000	Qwik Jon® Premier Ship-To-Home System. QJP & Toilet, 3 boxes.
202-2000	Qwik Jon® elongated toilet bowl.
202-3002	Qwik Jon® toilet tank and lid.
10-3050	Optional extension kit (available for recessed or behind-the-wall installations).
10-5090	Optional high water Qwik Alarm™ for Qwik Jon® Premier (201-0006).



When used with 1.28 gallon tank and fill valve



Model 202 meets the Americans with Disabilities Act guidelines and ANSI A117.1 requirements for accessible and usable facilities — check local codes



Product information presented here reflects conditions at time of publication. Consult factory regarding discrepancies or inconsistencies.

© Copyright 2024 Zoeller® Co. All rights reserved.

FM3290
0224
Supersedes
0123