

Qwik Jon<sup>®</sup>  
**CHOICE**



## Macerator Upflush System

Add a Bathroom Anywhere! No Gravity Drain Required!  
Making Bathroom Installations Easy!



**Zoeller Family of Water Solutions™**

Copyright Zoeller Co. All rights reserved.

## FEATURES AND BENEFITS:

- A quiet, preassembled macerator pump toilet system requiring minimal space for installation!
- Install a complete bathroom without breaking concrete!
- Easily connects to a tub, shower, sink, or other fixtures with 2" NPT or 1-1/2" (DN25) slip side inlets
- Install as a freestanding unit or behind a wall with the extension kit
- Automatic reset thermal overload protects the pump
- Carbon/Ceramic mechanical shaft seal for long life
- Upper and lower ball bearings for efficient and quiet operation
- Non-clogging vortex impeller for reliable operation
- Recessed side handles for carrying
- Convenient snap-fit covers for easy access to macerator and electrical junction box
- Discharge elbow with built-in check valve
- Standard 6' (1.8 m) cord

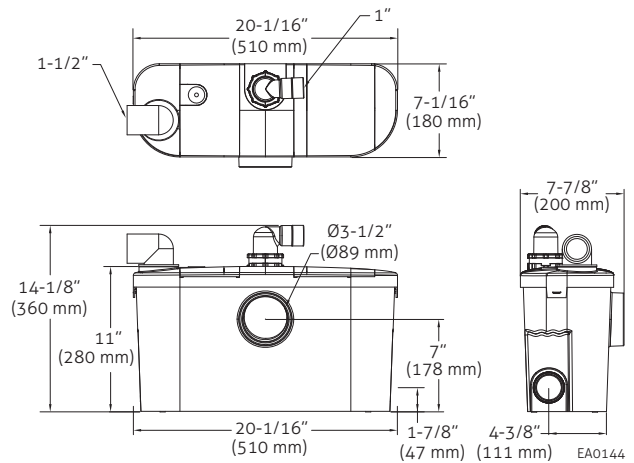
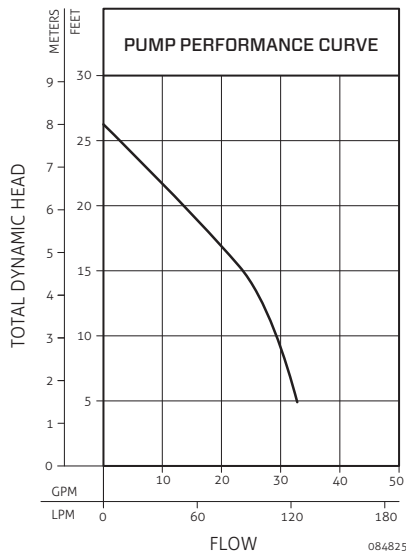
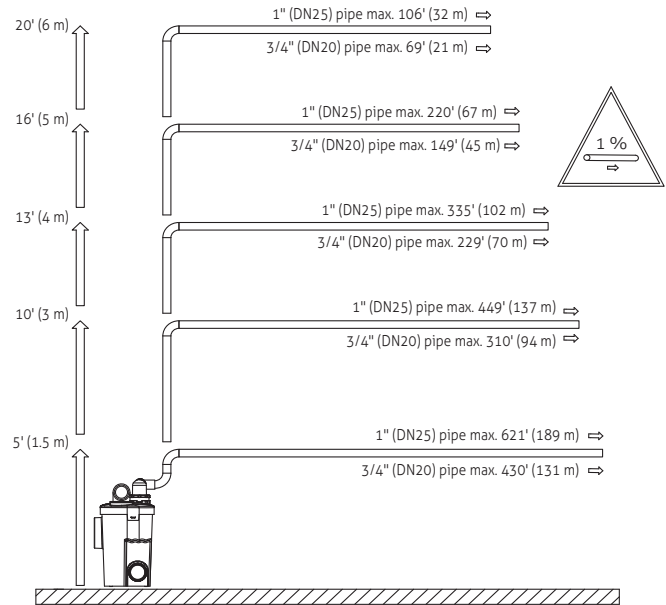

| Model | Mode            | Volts (V) | Ph Ø | Amps (A) | Motor |         | Weight |      |
|-------|-----------------|-----------|------|----------|-------|---------|--------|------|
|       |                 |           |      |          | HP    | kW (p1) | kg     | lbs  |
| 200   | Vertical Switch | 115       | 1    | 6.0      | 1/3   | 0.66    | 11     | 24.3 |

### Qwik Jon Choice Part Numbers:

| Model #  | Product  |
|----------|--|
| 200-0006 | Qwik Jon® Choice macerator pump and tank   |
| 200-0021 | Qwik Jon® Choice All-In-One System. QJC & Toilet, 1 box. Ships on a skid.        |
| 200-4000 | Qwik Jon® Choice Ship-to-Home System. QJC & Toilet, 3 boxes.                     |
| 202-2000 | Qwik Jon® elongated toilet bowl  |
| 202-3002 | Qwik Jon® toilet tank and lid  |
| 10-3050  | optional extension kit (available for recessed or behind-the-wall installations) |



When used with 1.28 gallon tank and fill valve

202-2000



Model 202 meets the Americans with Disabilities Act guidelines and ANSI A117.1 requirements for accessible and usable facilities — check local codes



Product information presented here reflects conditions at time of publication. Consult factory regarding discrepancies or inconsistencies.

© Copyright 2024 Zoeller® Co. All rights reserved.

FM3289  
0224  
Supersedes  
0123