

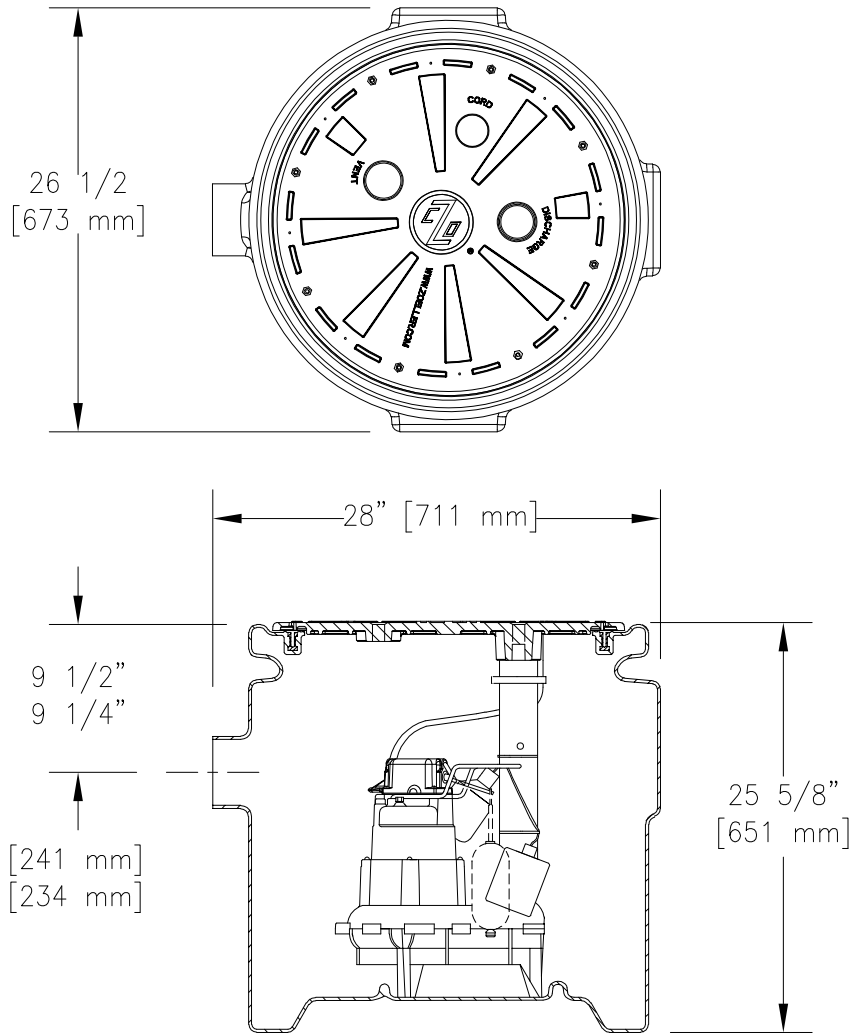

DRAWING REVISIONS

LTR	BY	DATE	ECO #	DESCRIPTION
C	GMP	03/08/18		ADD WEB ACCESS WARNING
D	PAB	01/08/19		LOWER INLET HEIGHT
E	PAB	03/09/20		ADD LIMITS INLET HEIGHT



THE INFORMATION ON THESE DRAWINGS OR WEB PAGES IS MADE AVAILABLE FOR YOUR USE. HOWEVER, YOU USE THE INFORMATION AT YOUR OWN RISK. WE BELIEVE THE INFORMATION TO BE CORRECT AND ACCURATE AT THE TIME OF ISSUE. ZOELLER COMPANY ASSUMES NO LIABILITY, EXPRESSED OR IMPLIED, RESULTING FROM YOUR ACCESSING AND USING THIS INFORMATION. DUE TO CHANGES AND/OR DOWNLOAD PROBLEMS, IT IS YOUR RESPONSIBILITY AND YOU AGREE TO BE SOLELY RESPONSIBLE TO VERIFY THAT THE INFORMATION IS CORRECT AND ACCURATE FOR YOUR PURPOSES.

DRAWING DESCRIPTION: ARCHITECTURAL SPEC. DWG. 912 SEWAGE EJECTOR SYS. 24X24 PSF BASIN ZCO PROPRIETARY		NUMBERS ENCLOSED IN A CIRCLE; ①, ARE CRITICAL TO QUALITY (CTQ) ITEMS. THIS INDICATES A CRUCIAL SPECIFICATION THAT MUST BE ROUTINELY VERIFIED.				
		© COPYRIGHT, 2019 : ALL RIGHTS RESERVED BY ZOELLER.				
TOLERANCES: .X ±~ .XXXX±~ .XX ±~ ANGLES ±~ .XXX ±~ FRACTIONS ±~		APPROVED:	ELECTRONIC SCALE: 1X DO NOT SCALE PRINT		PART NUMBER:	PART REVISION:
DRAFTER: D. DAVIS	DATE: 11/28/07		EXCEPT AS NOTED DIMENSIONS ARE IN INCHES.		DRAWING NUMBER: SK2694	
			SHEET: 1 OF 1			