

Trusted. Tested. Tough.®

U.S. Patent No.
8,562,287



SECTION: 2.25.050
FM2798
0923
Supersedes
0322

MAIL TO: P.O. BOX 16347 • Louisville, KY 40256-0347
SHIP TO: 3649 Cane Run Road • Louisville, KY 40211-1961
Tel: (502) 778-2731 • 1 (800) 928-PUMP

Visit our website:
zoellerpumps.com

Product information presented here reflects conditions at time of publication. Consult factory regarding discrepancies or inconsistencies.

THE SHARK^{Series} TECHNICAL DATA SHEET

SHARK GRINDER

Model 818/820 Single Seal Grinder Pumps

PRODUCT SPECIFICATIONS

MOTOR	Horse Power	1.0 - 2.0
	Voltage	115*, 200 & 230
	Phase	1 Ph
	Hertz	60 Hz
	RPM	3450
	Type	Capacitor start / capacitor run or 3 Ph
	Insulation	Class B
	Amps	6.5 - 15.5
PUMP	Operation	Automatic or nonautomatic
	Auto On / Off	Variable level float switch, customer sets
	Discharge Size	1-1/4" NPT vertical or horizontal
	Cord Length	20' (6 m) standard
	Cord Type	SOW or SOOW multi-wire neoprene
	Max. Head	107' (32.6 m)
	Max. Flow Rate	46 GPM (174 LPM)
	Max. Operating Temp.	130 °F (54 °C)
	Cooling	Oil filled
	Motor Protection	Auto reset thermal overload (1 Phase)
MATERIALS	Cap	Cast iron
	Motor Housing	Cast iron
	Adapter	Cast iron
	Pump Housing	Cast iron
	Upper Bearing	Ball bearing
	Lower Bearing	Ball bearing
	Mechanical Seals	Carbon/ceramic
	Impeller Type	Vortex
	Impeller	Engineered plastic with stainless steel insert
	Hardware	304 Stainless steel
	Motor Shaft	416 Stainless steel
	Gasket & Square Ring	Neoprene
	Cutter	Type 440C stainless steel hardened to Rockwell C55-60

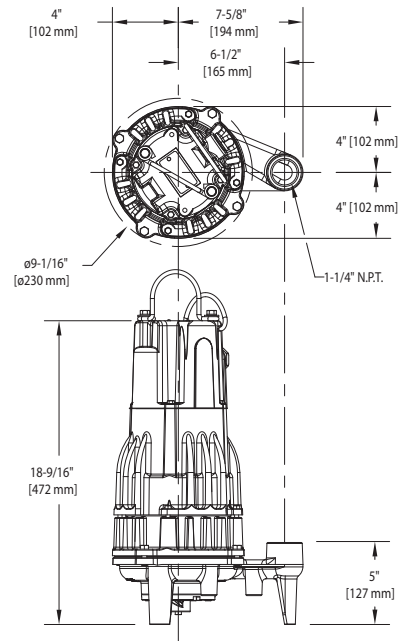

SK1621

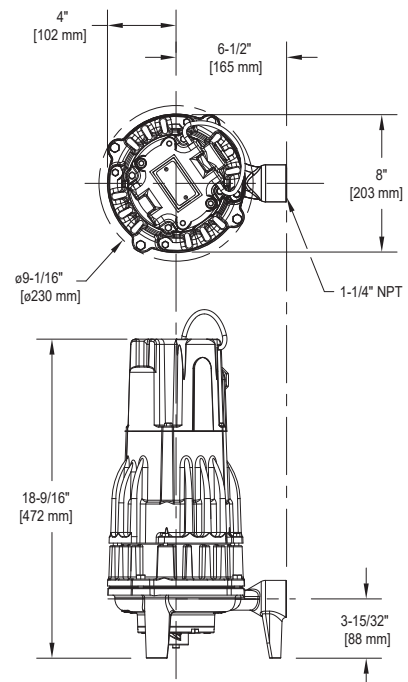

SK3352

*115 Volts for model 818 only



Tested to UL778 and
cCSAus 22.2 108
Standards.



© Copyright 2023 Zoeller® Co. All rights reserved.

502-778-2731 | 800-928-7867 | 3649 Cane Run Road | Louisville, KY 40211-1961 | zoellerpumps.com

TOTAL DYNAMIC HEAD FLOW PER MINUTE SEWAGE AND DEWATERING

MODEL		818		820	
Feet	Meters	Gal.	Liters	Gal.	Liters
5	1.5	43	163	46	174
10	3.0	42	159	46	174
15	4.6	40	151	46	174
20	6.1	37	140	46	174
25	7.6	33	125	46	174
30	9.1	28	106	46	174
35	10.7	22	83	46	174
40	12.2	16.5	62	46	174
50	15.2	-	-	46	174
60	18.3	-	-	43	163
70	21.3	-	-	36	136
80	24.4	-	-	27	102
90	27.4	-	-	16.7	63
100	30.5	-	-	7	26
Shut-off Head:		53 ft. (16.2m)		107 ft. (32.6m)	

154108

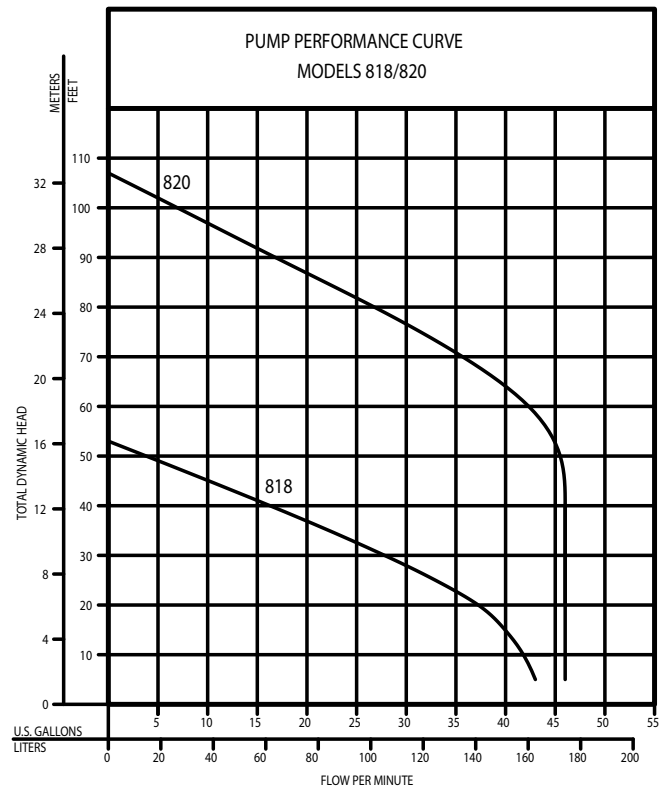

Model	MODEL COMPARISON								
	P/N	Mode	Volts	Ph	Amps	HP	Hz	Lbs	Kg
WM818	818-0006	Auto	115	1	13.6	1.0	60	89	40.3
N818	818-0002	Non	115	1	13.6	1.0	60	88	39.9
WH818	818-0008	Auto	200-208	1	7.7	1.0	60	89	40.3
I818	818-0005	Non	200-208	1	7.7	1.0	60	88	39.9
WD818	818-0007	Auto	230	1	6.5	1.0	60	89	40.3
E818	818-0004	Non	230	1	6.5	1.0	60	88	39.9
WH820	820-0005	Auto	200-208	1	15.5	2.0	60	89	40.3
I820	820-0006	Non	200-208	1	15.5	2.0	60	88	39.9
WD820	820-0011	Auto	230	1	13.7	2.0	60	89	40.3
E820	820-0004	Non	230	1	13.7	2.0	60	88	39.9

CAUTION All installation of controls, protection devices and wiring should be done by a qualified licensed electrician. All electrical and safety codes should be followed including the most recent National Electrical Code (NEC) and the Occupational Safety and Health Act (OSHA).

PUMP SYSTEM COMPONENTS

(A) GRINDER PUMP STANDARD FEATURES:

- Tri-slice® two-bladed, high-torque cutter
- Scissor-style cutting action cuts solids down to 7/32" and smaller
- 1-1/4" NPT vertical discharge
- Carbon/ceramic seal
- Thermal overload protection
- Engineered, glass-filled plastic impeller with stainless steel insert
- Stainless steel cutter and plate
- Stainless steel motor shaft
- Stainless steel hardware
- 20' (6 m) power cord

Options:

- Extra length cords
 ___ 25' ___ 35' ___ 50'

(B) CONTROL PANELS & ALARM SYSTEMS

STANDARD PANEL FEATURES:

- NEMA 4x
- Hand-Off-Automatic (H.O.A.) selector switch
- Lockable hasp
- Audible and visual high water alarm switch with silent switch
- Dry contacts
- Test switch for alarm and light
- UL listed

SIMPLEX PANELS: (For use with non-automatic pumps)

- P/N 31314-0001 1 Ph, 0-7.0 Amps
- P/N 31324-0001 1 Ph, 7.0-15.0 Amps

DUPLEX PANELS: (For use with non-automatic pumps)

- P/N 32314-0001 1 Ph, 0-7.0 Amps
- P/N 32324-0001 1 Ph, 7.0-15.0 Amps

HIGH WATER ALARMS: (For use with automatic pumps)

All alarms come with 15' variable level float switch.

- P/N 10-4012 standard indoor only (10-4011 reed switch)
- P/N 91104-0001 indoor/outdoor

(C) FLOAT SWITCHES

- 3 float switches required for simplex applications
- 3 or 4 float switches required for duplex applications
- Weight optional for high water alarms

- P/N 10-0744 Float switch w/ 20' cord
- P/N 10-1878 Float switch w/ 35' cord
- P/N 10-1879 Float switch w/ 50' cord
- P/N 10-0689 Weight only

(D) JUNCTION BOXES (optional)

SIMPLEX SYSTEM:

- P/N 10-0579 Qwik Box, 115 Volt, 15 Amp Max.
- P/N 10-0580 Qwik Box, 230 Volt, 20 Amp Max.
- P/N 10-0647 For 3-float outdoor package

DUPLEX SYSTEM:

- P/N 10-0648 For 3-float systems
- P/N 10-0649 For 4-float systems

(E) PREPACKAGED INDOOR SYSTEM STANDARD EQUIPMENT

- Fiberglass basin w/ fiberglass anti-flotation ring
- Rust-resistant steel cover (epoxy coated)
- Inspection plate
- Pump access cover (2) for duplex
- (1) 3" Adaptaflex vent seal

- (1) 1-1/4" Adaptaflex discharge pipe seal
- Cord seal
- (1) 4" Adaptaflex inlet pipe seal (field-installed)
- Pump support hardware
- 1-1/4" NPT cast iron check valve (2) for duplex
- 1-1/4" PVC Ball valve (2) for duplex

SIMPLEX SYSTEM:

- P/N 32-0011 Automatic models
 24" x 36" Fiberglass w/ inspection plate

DUPLEX SYSTEM:

- P/N 32-0009 30" x 36" Fiberglass w/ 3 float inspection plate
- P/N 32-0010 30" x 36" Inspection plate basin w/ 4 float inspection plate

TYPICAL SIMPLEX INDOOR SYSTEM

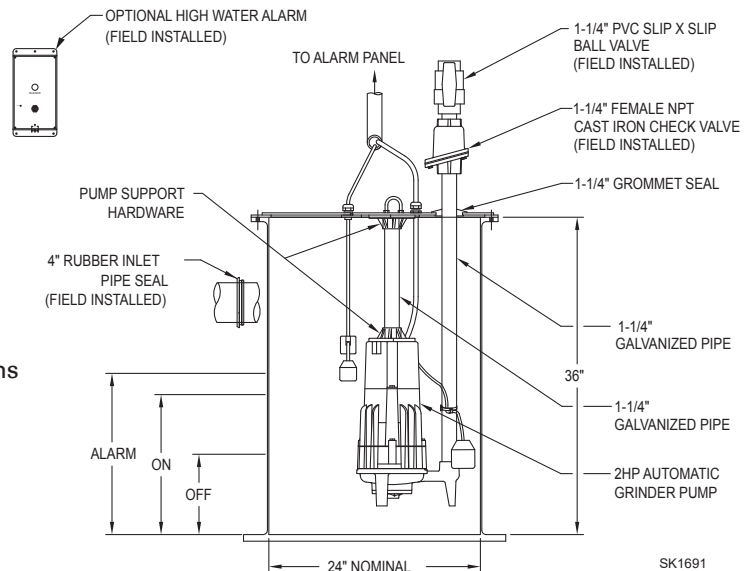

PREPACKAGED AND JOB READY SYSTEMS - INDOOR	
	REQ.
Grinder (auto or nonauto)	P/N _____ (A)
Control Panel or alarm	P/N _____ (B)
Floats and weights	P/N _____ (C)
Junction Box (optional)	P/N _____ (D)
Basin, cover and hardware	P/N _____ (E)

(F) PREPACKAGED OUTDOOR SYSTEM WITH Z-RAIL® TECHNOLOGY

- Fiberglass basin with fiberglass anti-flotation ring
- 2" Schedule 80 PVC discharge piping
- 1-1/4" x 2" Z-Rail® disconnect system, epoxy coated ductile iron
- 3/4" Galvanized rail pipes
- Stainless steel lifting cable and bail
- 2" PVC ball valve (installed)
- 2" cast iron check valve (installed)
- Pre-wired PVC float tree
- (1) 4" rubber inlet pipe seal (field install)
- (1) 2" pipe seal (field install) for electrical conduit
- Solid fiberglass cover with Zoeller imprint

PREPACKAGED AND JOB READY SYSTEMS - OUTDOOR	
	REQ.
Grinder (auto or nonauto)	P/N _____ (A)
Control panel/alarm system	P/N _____ (B)
Floats and weights	P/N _____ (C)
Junction Box (optional)	P/N _____ (D)
Basin, cover and rail system	P/N _____ (F)

SIMPLEX

<input type="checkbox"/>	24" x 48" (61 x 122 cm)	P/N 33-2054
<input type="checkbox"/>	24" x 60" (61 x 152 cm)	P/N 33-2057
<input type="checkbox"/>	24" x 72" (61 x 183 cm)	P/N 33-2060
<input type="checkbox"/>	24" x 84" (61 x 213 cm)	P/N 33-2063
<input type="checkbox"/>	24" x 96" (61 x 244 cm)	P/N 33-2069
<input type="checkbox"/>	24" x 108" (61 x 274 cm)	P/N 33-2075
<input type="checkbox"/>	24" x 120" (61 x 305 cm)	P/N 33-2078

<input type="checkbox"/>	30" x 48" (76 x 122 cm)	P/N 33-2081
<input type="checkbox"/>	30" x 60" (76 x 152 cm)	P/N 33-2084
<input type="checkbox"/>	30" x 72" (76 x 183 cm)	P/N 33-2087
<input type="checkbox"/>	30" x 84" (76 x 213 cm)	P/N 33-2090
<input type="checkbox"/>	30" x 96" (76 x 244 cm)	P/N 33-2096
<input type="checkbox"/>	30" x 108" (76 x 274 cm)	P/N 33-2102
<input type="checkbox"/>	30" x 120" (76 x 305 cm)	P/N 33-2105

DUPLX

<input type="checkbox"/>	36" x 48" (91 x 122 cm)	P/N 33-2108
<input type="checkbox"/>	36" x 60" (91 x 152 cm)	P/N 33-2111
<input type="checkbox"/>	36" x 72" (91 x 183 cm)	P/N 33-2114
<input type="checkbox"/>	36" x 84" (91 x 213 cm)	P/N 33-2117
<input type="checkbox"/>	36" x 96" (91 x 244 cm)	P/N 33-2123
<input type="checkbox"/>	36" x 108" (91 x 274 cm)	P/N 33-2129
<input type="checkbox"/>	36" x 120" (91 x 305 cm)	P/N 33-2132

<input type="checkbox"/>	48" x 48" (122 x 122 cm)	P/N 33-2135
<input type="checkbox"/>	48" x 60" (122 x 152 cm)	P/N 33-2138
<input type="checkbox"/>	48" x 72" (122 x 183 cm)	P/N 33-2141
<input type="checkbox"/>	48" x 84" (122 x 213 cm)	P/N 33-2144
<input type="checkbox"/>	48" x 96" (122 x 244 cm)	P/N 33-2150
<input type="checkbox"/>	48" x 108" (122 x 274 cm)	P/N 33-2156
<input type="checkbox"/>	48" x 120" (122 x 305 cm)	P/N 33-2159

OPTIONS

- Steel hatch cover
- Aluminum hatch cover
- Special sizes and configurations (consult factory)

LIBERTY - 39-0182

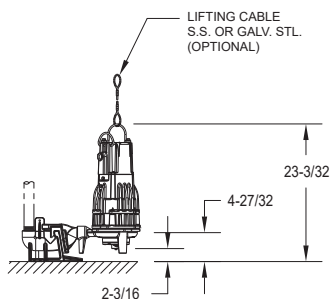
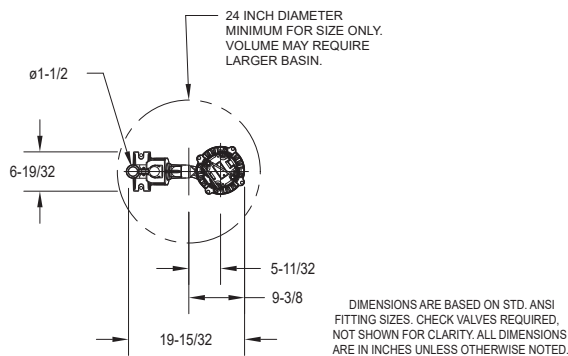

SK3357

FLYGT - 39-0183

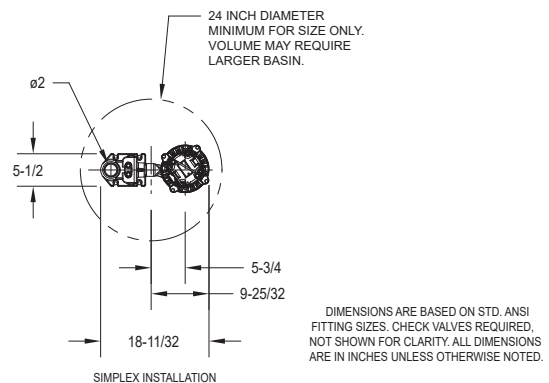

SIMPLEX INSTALLATION

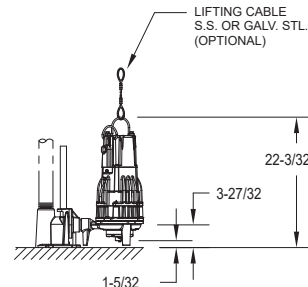

SK3356

TYPICAL SIMPLEX OUTDOOR SYSTEM

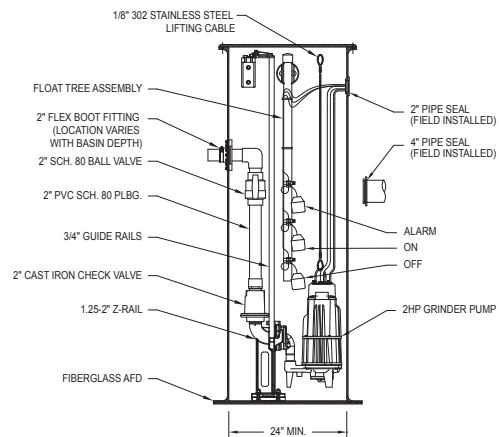
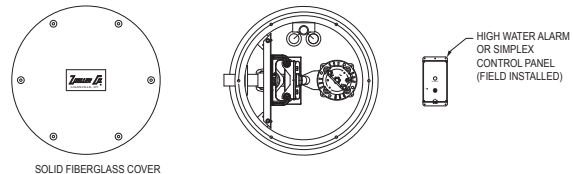

SK3110

Note: For other competitor adapters consult factory
"Liberty is trademark of Liberty Pumps".

© Copyright 2023 Zoeller® Co. All rights reserved.

502-778-2731 | 800-928-7867 | 3649 Cane Run Road | Louisville, KY 40211-1961 | zoellerpumps.com