

Notice to installing contractor: Instructions must remain with installation.  
Trusted. Tested. Tough.®

FM2681

0823

Supersedes

0515

DATE INSTALLED:
MODEL NUMBER:



MAIL TO: P.O. BOX 16347 • Louisville, KY 40256-0347  
SHIP TO: 3649 Cane Run Road • Louisville, KY 40211-1961  
Tel: (502) 778-2731 • 1 (800) 928-PUMP

Visit our website:  
zoellerpumps.com

Product information presented here reflects conditions at time of publication. Consult factory regarding discrepancies or inconsistencies.



POWERED BY  
**ZMW**  
53 pump powered by  
Zoeller Motor Works motor

Register your  
Zoeller Pump Company  
Product on our website:  
<http://reg.zoellerpumps.com/>



## INSTALLATION INSTRUCTIONS MODEL 900 PREPACKAGED SYSTEMS

### EFFLUENT/SUMP/DEWATERING



900-0008 24 x 24 Simplex Basin Assembly with Pro Pak Backup System

900-0009 24 x 30 Duplex Basin Assembly with M53 and Pro Pak Backup System

P/N 152042

## PREINSTALLATION CHECKLIST - ALL INSTALLATIONS

- Inspect your pump.** Occasionally, products are damaged during shipment. If the unit is damaged, contact your dealer before using. **DO NOT** remove the test plugs in the cover nor the motor housing.
- Carefully read the literature** provided to familiarize yourself with specific details regarding installation and use. These materials should be retained for future reference.

 <b>WARNING</b> SEE BELOW FOR LIST OF WARNINGS	 <b>CAUTION</b> SEE BELOW FOR LIST OF CAUTIONS
<ol style="list-style-type: none"> <li>Make certain that the receptacle is within the reach of the pump's power supply cord. <b>DO NOT USE AN EXTENSION CORD.</b> Extension cords that are too long or too light do not deliver sufficient voltage to the pump motor. But, more important, they could present a safety hazard if the insulation were to become damaged or the connection end were to fall into the sump.</li> <li><b>Make sure the pump electrical supply circuit is equipped with fuses or circuit breakers of proper capacity.</b> A separate branch circuit is recommended, sized according to the "National Electrical Code" for the current shown on the pump nameplate.</li> <li><b>Testing for ground.</b> As a safety measure, each electrical outlet should be checked for ground using an Underwriters Laboratory Listed circuit analyzer which will indicate if the power, neutral and ground wires are correctly connected to your outlet. If they are not, call a qualified licensed electrician.</li> <li><b>For Added Safety.</b> Pumping and other equipment with a 3-prong grounded plug must be connected to a 3-prong grounded receptacle. For added safety the receptacle may be protected with a ground-fault circuit interrupter. When a pump needs to be connected in a watertight junction box, the plug can be removed and spliced to the supply cable with proper grounding. For added safety this circuit may be protected by a ground-fault circuit interrupter. The complete installation must comply with the National Electrical Code and all applicable local codes and ordinances.</li> <li><b>FOR YOUR PROTECTION, ALWAYS DISCONNECT PUMP FROM ITS POWER SOURCE BEFORE HANDLING.</b> Single phase pumps are supplied with a 3-prong grounded plug to help protect you against the possibility of electrical shock. <b>DO NOT UNDER ANY CIRCUMSTANCES REMOVE THE GROUND PIN.</b> The 3-prong plug <b>must</b> be inserted into a mating 3-prong grounded receptacle. If the installation does not have such a receptacle, it must be changed to the proper type, wired and grounded in accordance with the National Electrical Code and all applicable local codes and ordinances. Three phase pumps require motor starting devices with motor overload protection. See FM0486 for duplex installations.</li> <li>The tank is to be vented in accordance with local plumbing code. Pumps <b>must</b> be installed in accordance with the National Electrical Code and all applicable local codes and ordinances. Pumps are not to be installed in locations classified as hazardous in accordance with National Electrical Code, ANSI/NFPA 70.</li> <li><b>"Risk of electrical shock"</b> Do not remove power supply cord and strain relief or connect conduit directly to the pump.</li> <li>Installation and servicing of electrical circuits and hardware should be performed by a qualified licensed electrician.</li> <li>Pump installation and servicing should be performed by a qualified person.</li> <li>Risk of electric shock - These pumps have not been investigated for use in swimming pool and marine areas.</li> <li>Prop65 Warning for California residents: Cancer and Reproductive Harm- <a href="http://www.P65warnings.ca.gov">www.P65warnings.ca.gov</a>.</li> </ol>	<ol style="list-style-type: none"> <li>Check to be sure your power source is capable of handling the voltage requirements of the motor, as indicated on the pump name plate.</li> <li>The installation of automatic pumps with variable level float switches or nonautomatic pumps using auxiliary variable level float switches is the responsibility of the installing party and care should be taken that the tethered float switch will not hang up on the pump apparatus or pit peculiarities and is secured so that the pump will shut off. It is recommended to use rigid piping and fittings and the pit be 18" or larger in diameter.</li> <li>Pump should be checked frequently for debris and/or build up which may interfere with the float "on" or "off" position. Repair and service should be performed by Zoeller Pump Company Authorized Service Station only.</li> <li>Dewatering and effluent sump pumps are not designed for use in pits handling raw sewage.</li> <li>Maximum operating temperature for standard model pumps must not exceed 130°F (54°C).</li> <li>Pump models 266, 267, 268, and 137 must be operated in an upright position. Do not attempt to start pump when tilted or laying on its side.</li> <li>Do not operate a pump in an application where the Total Dynamic Head is less than the minimum Total Dynamic Head listed on the Pump Performance Curves.</li> </ol> <p>NOTE: Pumps with the "UL" mark and pumps with the "US" mark are tested to UL Standard UL778. CSA Certified pumps are certified to CSA Standard C22.2 No. 108.</p>
<b>REFER TO WARRANTY ON PAGE 2.</b>	

## LIMITED WARRANTY

Manufacturer warrants, to the purchaser and subsequent owner during the warranty period, every new product to be free from defects in material and workmanship under normal use and service, when properly used and maintained, for a period of three years from the date of original manufacture. Parts that fail within the warranty period, that inspections determine to be defective in material or workmanship, will be repaired, replaced or remanufactured at Manufacturer's option, provided however, that by so doing we will not be obligated to replace an entire assembly, the entire mechanism or the complete unit. No allowance will be made for shipping charges, damages, labor or other charges that may occur due to product failure, repair or replacement.

This warranty does not apply to and there shall be no warranty for any material or product that has been disassembled without prior approval of Manufacturer, subjected to misuse, misapplication, neglect, alteration, accident or act of God; that has not been installed, operated or maintained in accordance with Manufacturer's installation instructions; that has been exposed to outside substances including but not limited to the following: sand, gravel, cement, mud, tar, hydrocarbons, hydrocarbon derivatives (oil, gasoline, solvents, etc.), or other abrasive or corrosive substances, wash towels or feminine sanitary products, etc. in all pumping applications. The warranty set out in the paragraph above is

in lieu of all other warranties expressed or implied; and we do not authorize any representative or other person to assume for us any other liability in connection with our products.

Contact Manufacturer at, 3649 Cane Run Road, Louisville, Kentucky 40211, Attention: Customer Service Department to obtain any needed repair or replacement of part(s) or additional information pertaining to our warranty.

**MANUFACTURER EXPRESSLY DISCLAIMS LIABILITY FOR SPECIAL, CONSEQUENTIAL OR INCIDENTAL DAMAGES OR BREACH OF EXPRESSED OR IMPLIED WARRANTY; AND ANY IMPLIED WARRANTY OF FITNESS FOR A PARTICULAR PURPOSE AND OF MERCHANTABILITY SHALL BE LIMITED TO THE DURATION OF THE EXPRESSED WARRANTY.**

Some states do not allow limitations on the duration of an implied warranty, so the above limitation may not apply to you. Some states do not allow the exclusion or limitation of incidental or consequential damages, so the above limitation or exclusion may not apply to you.

This warranty gives you specific legal rights and you may also have other rights which vary from state to state.

**In those instances where damages are incurred as a result of an alleged pump failure, the homeowner must retain possession of the pump for investigation purposes.**

## SERVICE CHECKLIST



**⚠ WARNING**

**ELECTRICAL PRECAUTIONS-** Before servicing a pump, always shut off the main power breaker and then unplug the pump - making sure you are wearing insulated protective sole shoes and not standing in water. Under flooded conditions, contact your local electric company or a qualified licensed electrician for disconnecting electrical service prior to pump removal.

**⚠ WARNING**

Submersible pumps contain oils which becomes pressurized and hot under operating conditions - **allow 2½ hours after disconnecting before attempting service.**

CONDITION	COMMON CAUSES
<b>A. Pump will not start or run.</b>	Check fuse, low voltage, overload open, open or incorrect wiring, open switch, impeller or seal bound mechanically, defective capacitor or relay when used, motor or wiring shorted. Float assembly held down. Switch defective, damaged, or out of adjustment.
<b>B. Motor overheats and trips overload or blows fuse.</b>	Incorrect voltage, negative head (discharge open lower than normal) impeller or seal bound mechanically, defective capacitor or relay, motor shorted.
<b>C. Pump starts and stops too often.</b>	Float tight on rod, check valve stuck or none installed in long distance line, overload open, level switch(s) defective, sump pit too small.
<b>D. Pump will not shut off.</b>	Debris under float assembly, float or float rod bound by pit sides or other, switch out of adjustment.
<b>E. Pump operates but delivers little or no water.</b>	Check strainer housing, discharge pipe, or if check valve is used vent hole must be clear. Discharge head exceeds pump capacity. Low or incorrect voltage. Incorrect motor rotation. Capacitor defective. Incoming water containing air or causing air to enter pumping chamber.
<b>F. Drop in head and/or capacity after a period of use.</b>	Increased pipe friction, clogged line or check valve. Abrasive material and adverse chemicals could possibly deteriorate impeller and pump housing. Check line. Remove base and inspect.

If the above checklist does not uncover the problem, consult the factory - Do not attempt to service or otherwise disassemble pump. Service must be performed by Zoeller Authorized Service Stations. Go to [www.zoellerpumps.com/servicestations](http://www.zoellerpumps.com/servicestations) to find the Authorized Service Station in your area.

## EASY DO'S & DON'T'S FOR INSTALLING A SUMP PUMP

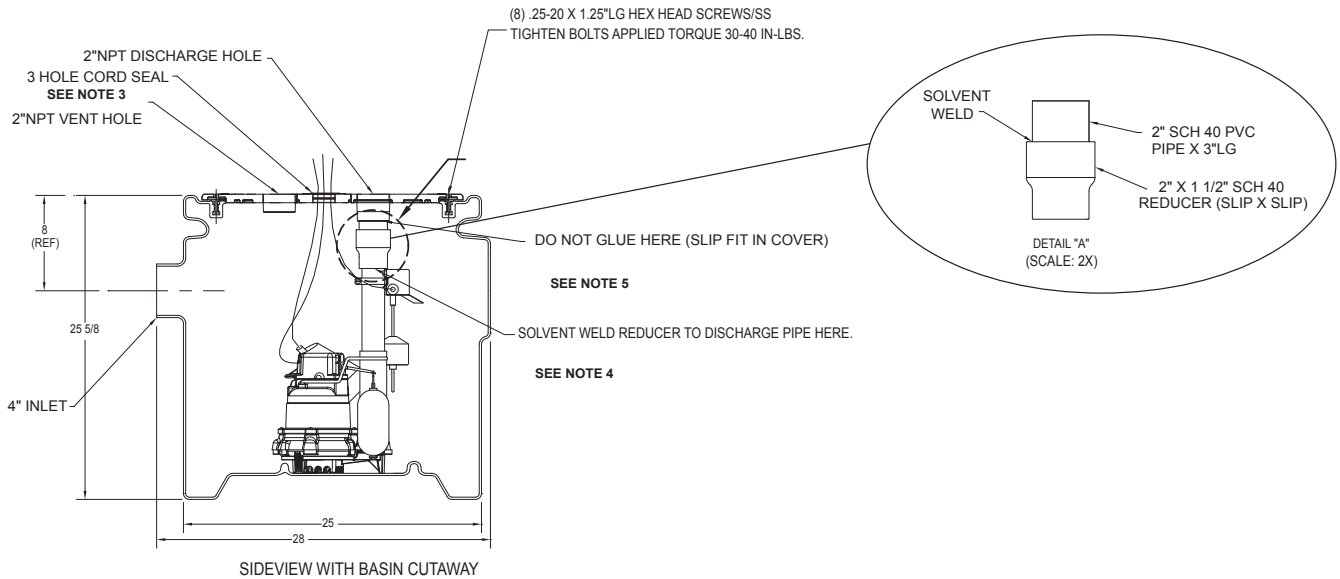
1. **DO** read thoroughly all installation material provided with the pump.
2. **DO** inspect pump for any visible damage caused by shipping. Contact dealer if pump appears to be damaged.
3. **DO** clean all debris from the sump. Be sure that the pump will have a hard, flat surface beneath it. **DO NOT** install on sand, gravel or dirt.
4. **DO** be sure that the sump is large enough to allow proper clearance for the level control switch(es) to operate properly.
5. **DO Always Disconnect Pump From Power Source Before Handling.**  
**DO** always connect to a separately protected and properly grounded circuit.  
**DO NOT** ever cut, splice, or damage power cord (Only splice in a watertight junction box).  
**DO NOT** carry or lift pump by its power cord.  
**DO NOT** use an extension cord with a sump pump.
6. **DO** install a union in the discharge line.  
**DO NOT** use a discharge pipe smaller than the pump discharge.
7. **DO NOT** use a sump pump as a trench or excavation pump, or for pumping sewage, gasoline, or other hazardous liquids.
8. **DO** test pump immediately after installation to be sure that the system is working properly.
9. **DO** cover sump with an adequate sump cover.
10. **DO** review all applicable local and national codes and verify that the installation conforms to each of them.
11. **DO** consult manufacturer for clarifications or questions.
12. **DO** consider a two pump system with an alarm where an installation may become overloaded or primary pump failure would result in property damages.
13. **DO** consider a D.C. Backup System where a sump or dewatering pump is necessary for the prevention of property damages from flooding due to A.C. power disruptions, mechanical or electrical problems or system overloading.
14. **DO** inspect and test system for proper operations at least every three months.

# INSTALLATION INSTRUCTIONS FOR 24 X 24 SIMPLEX BASIN ASSEMBLY

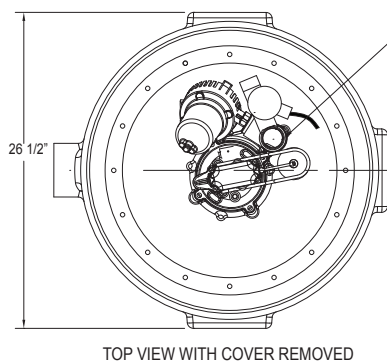
1. With basin installed in floor, remove cover from basin.
2. Remove pump with backup pump from carton.
3. Thread all power cords through cord hole in cover and insert cords in 3-hole cord seal. Place lubricant on O.D. of cord seal and insert into cover. (See Fig. 1)  
**NOTE:** Adjust cords as necessary to eliminate interference of cords with floats, switches, etc.
4. Assemble PVC pipe reducer and 2" diameter pipe x 3" lg. by solvent welding (PVC glue). Assemble reducer to pump discharge, per Detail "A".  
**NOTE:** Pump sits inside of stops.

6. Assemble cover to basin making sure that discharge pipe slips into collar on bottom of cover. Attach vent and discharge pipe using 2" NPT holes in cover. Use full-size discharge pipe.  
**NOTE:** Cover must be oriented per instructions (Fig. 3). Basin must be in accordance with applicable codes and specifications. Pump must be level and float mechanisms clear of sides of basin before starting pump. Basin must be clean and free of debris after installation.
7. Refer to Installation Instructions FM2562 for additional details pertaining to the "Pro Pak" System.

**Fig. 1**

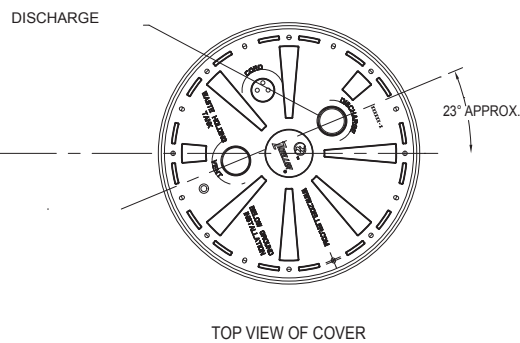


**Fig. 2**



MUST ALIGN  
SEE NOTE 5 & 6

**Fig. 3**



SK2915

# INSTALLATION INSTRUCTIONS FOR 24 X 30 DUPLEX BASIN ASSEMBLY

1. With basin installed in floor, remove cover from basin.
  2. Remove M53 pump and M53 with backup pump from cartons.
  3. Thread all power cords through cord hole in cover and insert cords in 3-hole cord seal. Place lubricant on O.D. of cord seal and insert into cover.
  4. Put M53 pump cord through appropriate cord hole in cover and insert cord in 1 hole cord seal. Place lubricant on O.D. of cord seal and insert in cover.
- NOTE:** Adjust cords as necessary to eliminate interference of cords with floats, switches, etc.
5. Place pumps in basin oriented as shown in Fig. 2.
  6. Assemble PVC pipe coupling to the backup pump discharge pipe and insert 1.5" pipe x 15" long in coupling by solvent welding (PVC glue). See Fig. 1.

7. Assemble 1.5" MPT x 1.5" socket adapter to M53 pump discharge (Fig.1).
8. Assemble PVC pipe (1.5" x 32" long with weep hole) in adapter by solvent welding (Fig. 1).
9. Assemble cover to basin making sure that discharge pipes align with appropriate holes in cover. See Fig. 3. Attach vent using 3" NPT flange on cover. Use full-size discharge pipe.
10. Refer to Installation Instructions FM2562 for additional details pertaining to the "Pro Pak" System.

**NOTE:** Cover must be oriented per instructions (Fig. 3). Basin must be in accordance with applicable codes and specifications. Pump must be level and float mechanisms clear of sides of basin before starting pump. Basin must be clean and free of debris after installation.

FIG. 2

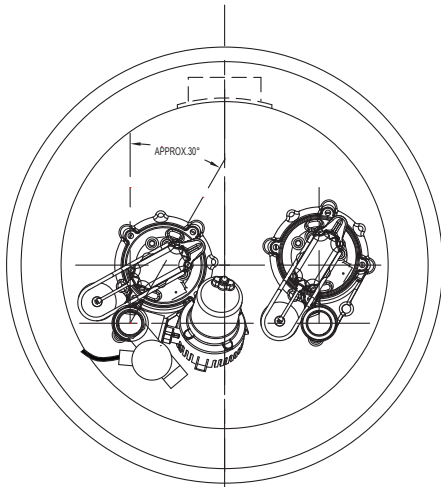


FIG. 1

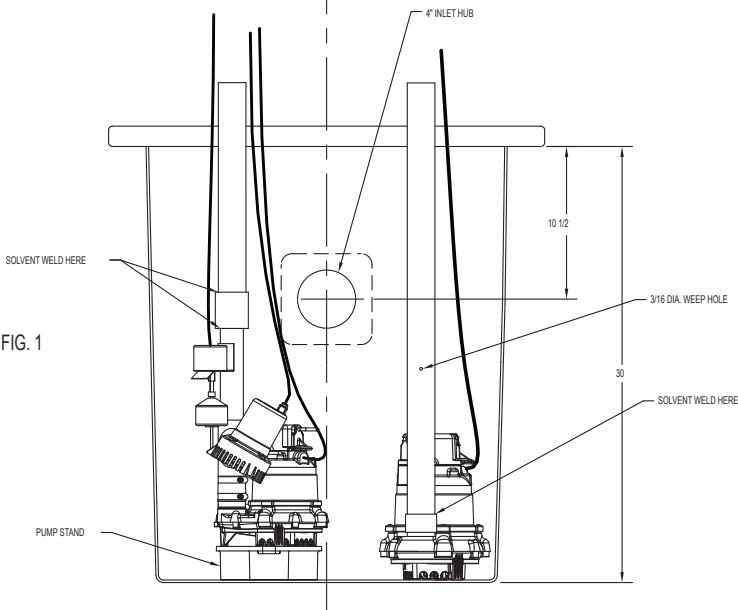
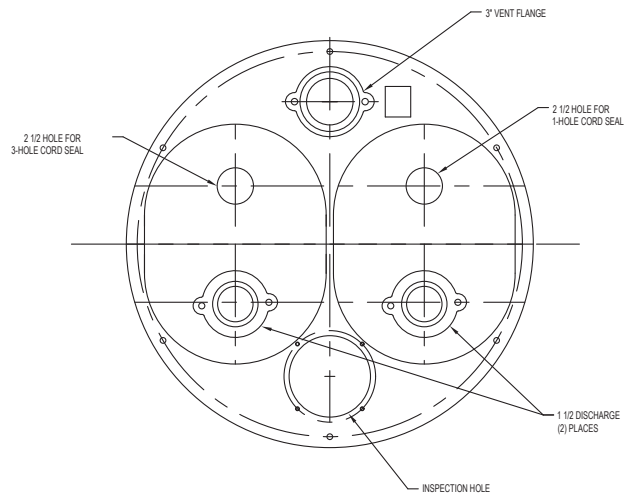


FIG. 3  
24" COVER



SK2921



MAIL TO: P.O. BOX 16347 • Louisville, KY 40256-0347  
 SHIP TO: 3649 Cane Run Road • Louisville, KY 40211-1961  
 Tel: (502) 778-2731 • 1 (800) 928-PUMP

Trusted. Tested. Tough.®

Visit our website:  
[zoellerpumps.com](http://zoellerpumps.com)