

Product information presented here reflects conditions at time of publication. Consult factory regarding discrepancies or inconsistencies.



50/60Hz

MAIL TO: P.O. BOX 16347 • Louisville, KY 40256-0347 USA
SHIP TO: 3649 Cane Run Road • Louisville, KY 40211-1961 USA
+1 (502) 778-2731 • 1-800-928-7867 • FAX +1 (502) 774-3624

visit our web site:
zoellerpumps.com

**REPLACEMENT PARTS LIST
FOR GRINDER MODELS:**

- E815 NONAUTOMATIC 230V 1PH 60 HZ
- I815 NONAUTOMATIC 200V 1PH 60 HZ
- RE815 NONAUTOMATIC / MANUAL RUN 230V 1PH 60 HZ
- RI815 NONAUTOMATIC / MANUAL RUN 200V 1PH 60 HZ
- RWD815 AUTOMATIC / MANUAL RUN W/WIRED FLOAT SWITCH 230V 1PH 60HZ
- RWH815 AUTOMATIC / MANUAL RUN W/WIRED FLOAT SWITCH 200V 1PH 60HZ
- Z815 NONAUTOMATIC / 230V 1PH 50 HZ

Consult factory for all other models.

TO ORDER REPLACEMENT PARTS

PLEASE FURNISH THE FOLLOWING INFORMATION:

- Model number
- Part number of pump
- Part number and description of part

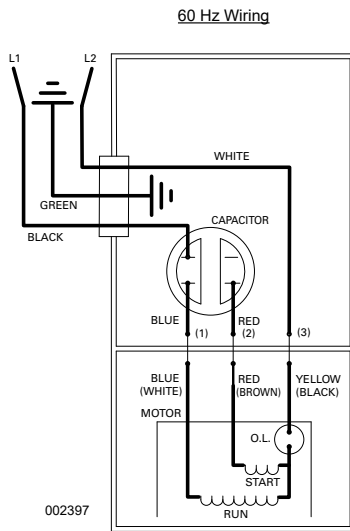

WIRING DIAGRAM FOR MODELS "E815", "I815", & "Z815"
All revisions thru Current

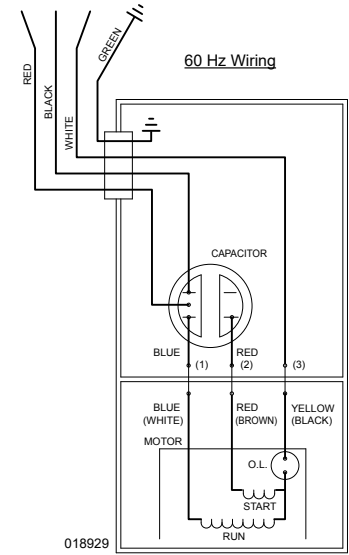

WIRING DIAGRAM FOR MODELS "E815-A" and "E815-B"
Manual Run Option
4/07 thru 3/13

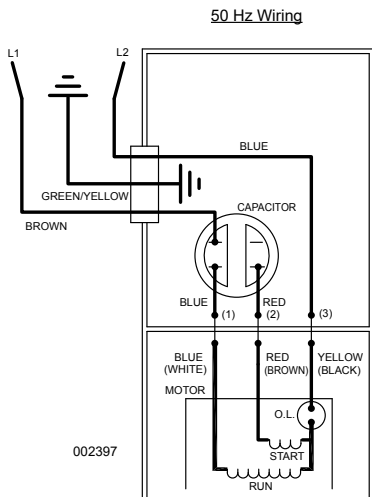

WIRING DIAGRAM FOR MODEL "Z815"
8/06 thru Current

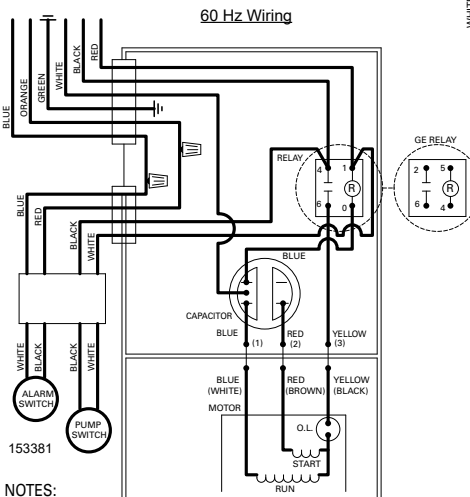

NOTES:
1) INSULATORS REQUIRED ON GE RELAY TERMINALS 2 & 5;
OMRON RELAY TERMINALS 1 & 4.

WIRING DIAGRAM FOR MODELS "RWD815", "RE815", "RWH815"
All revisions thru Current

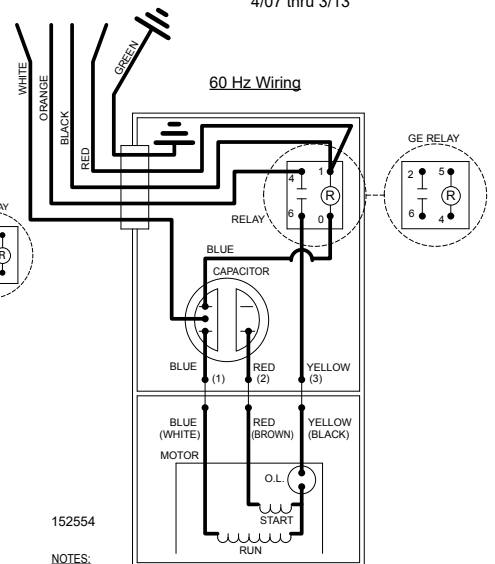

NOTES:
1) INSULATORS REQUIRED ON GE RELAY TERMINALS 2 & 5;
OMRON RELAY TERMINALS 1 & 4.

WIRING DIAGRAM FOR MODELS "RE-815" & "RI815"
all revisions thru Current

REPLACEMENT PARTS LIST FOR MODEL "E815"

See page 7 for illustration.

REF NO.	DESCRIPTION	QTY	NOTES	MODELS:				
				E815-A	E815-B	E815-C	E815-D	I815-A
				8/06 thru 8/07	9/07 thru 12/07	1/08 thru 5/16	6/16 thru Current	4/20 thru Current
1	• HANDLE	1		217069	217069	217069	217069	217069
2	COVER & CORD (CORD - 20' (6 M) LENGTH SOW 15A PLUG)	1	2	002401	002401	002401	002401	N/A
	COVER & CORD (CORD - 20' (6 M) LENGTH SOW NO PLUG)			N/A	N/A	N/A	N/A	013883
	COVER & CORD (CORD 33' (10 M) LENGTH H07RN-F3G1.5 NO PLUG/CE)			N/A	N/A	N/A	N/A	N/A
3	CORD, TERM & SEAL ASM (CORD - 20' (6 M) LENGTH SOW 15A PLUG)	1	2	002402	002402	002402	002402	N/A
	CORD, TERM & SEAL ASM (CORD - 20' (6 M) LENGTH SOW NO PLUG)			N/A	N/A	N/A	N/A	005391
	CORD, TERM & SEAL ASM (CORD 33' (10 M) LENGTH H07RN-F3G1.5 NO PLUG)			N/A	N/A	N/A	N/A	N/A
4	• SEAL, CORD-ASM & STRAIN RELIEF	1	2	094032	094032	094032	094032	094032
5	COVER-MACH. (CORD, SOW)	1		001077	001077	001077	001077	001077
	COVER-MACH. (CORD, H07RN-F3G1.5/CE)			N/A	N/A	N/A	N/A	N/A
6	• GASKET, CASE/COVER	1		001011	001011	001011	001011	001011
7	• WIRE PKG.	1		011092	011092	011092	011092	011092
8	CAPACITOR & CLAMP ASM	1		010666	010666	151706	151706	151706
9	• PLUG, TEST	2		015023	015023	015023	015023	015023
10	• SEAL, THRU WALL TERM	3		003402	003402	003402	003402	003402
11	HOUSING, MOTOR & STATOR	1	1	018909	018909	018909	018909	150961
12	• SPRING, BEARING PRELOAD	1		017192	017192	017192	017192	017192
13	• BEARING, UPPER 6201	1		006703	006703	006703	006703	006703
14	ROTOR & BEARING ASM	1		018911	018911	018911	018911	018911
15	• KEY	1		017893	017893	017893	017893	017893
16	• BEARING, LOWER 6204	1		012544	012544	012544	012544	012544
17	• SEAL, MOTOR HOUSING	1		001014	001014	001014	001014	001014
18	• OIL, DIELECTRIC-(57 OZ CAN)	1		009051	009051	009051	009051	009051
19	ADAPTER-MACH.	1		017891	017891	017891	017891	017891
20	• SEAL, SHAFT	1		018912	018912	018912	018912	018912
21	• WASHER, SEAL LOCATING & SNAP RING	1		018913	018913	018913	018913	018913
22	ROTOR, PUMP-HYDRAULIC & PIN	1		018914	018915	018915	018915	018915
23	• PIN	1		017892	018892	018892	018892	018892
24	• SEAL, PUMP HOUSING	1		017894	017894	017894	017894	017894
25	HOUSING, PUMP-MACH. & PRESS. RLF VALVE	1		018917	018917	019551	019551	019551
26	LEG, WIREFORM	2		017841	017841	017841	017841	017841
27	VALVE, PRESSURE RELIEF	1		018433	018433	018433	018433	018433
28	STATOR, HYDRAULIC	1		151617	151617	151617	151617	151617
29	• INSERT, STATOR SS	6		018369	018369	018369	018369	018369
30	CUTTER & DISC ASM 810/815	1		018918	018918	018918	154184	154184
31	SHIM SET	1		012632	012632	012632	012632	012632
32	CLAMP, STRAIN RELIEF (CORD, SOW)	1		001770	001770	001770	001770	001770
	CLAMP, STRAIN RELIEF (CORD, H07RN-F3G1.5)	1		N/A	N/A	N/A	N/A	N/A
33	• SCREW, .25-20 X .75 HHM-SS	4		001916	001916	001916	001916	001916
34	• SCREW, #6-32 X .25 RHM SL TC STLGR	3		001877	001877	001877	001877	001877
35	• SCREW, .25-20 X 1 HHM-SS	4		007790	007790	007790	007790	007790
36	• SCREW, .313-18 X 2 HH CAP FULL THREAD/SS	4		018186	018186	018186	018186	018186
37	• WASHER, FLAT-SS .313	4		015914	015914	015914	015914	015914
38	• NUT, .313-18 H-SS	4		001813	001813	001813	001813	001813
39	• WASHER, RETAINING SS	1		008533	008533	008533	008533	008533
40	• SCREW, .25-20 X .75 HH SS (NYLOCK)	1		009545	009545	009545	009545	009545
41	• WASHER, FLAT-SS .25	6	5	004480	004480	004480	N/A	N/A
42	• SCREW, .25-20 X .875 (1.125 LENGTH FOR PLATE W/O RECESS)	6		018387	018387	018387	153205	153205
43	DISC, CUTTER	1		010407	010407	010407	153203	153203
44	CUTTER/SHIM ASM/3 BLADE	1		019695	019695	019695	154185	154185
45	RELAY	0		N/A	N/A	N/A	N/A	N/A
46	INSULATION - INSULATOR	0		N/A	N/A	N/A	N/A	N/A
47	SWITCH, FLTS - TERM & SEAL	0		N/A	N/A	N/A	N/A	N/A
48	• SEAL, CORD - FLT SWITCH	0		N/A	N/A	N/A	N/A	N/A
49	• CONNECTOR WIRENUT	0		N/A	N/A	N/A	N/A	N/A
o	REBUILD KIT			018919	018920	018920	018920	018920

• Items included in Rebuild Kit.

o Not Shown in Illustration.

REPLACEMENT PARTS LIST FOR MODEL "Z815"

See page 7 for illustration.

REF NO.	DESCRIPTION	QTY	NOTES	MODELS:	
				Z815-A	Z815-B
1	• HANDLE	1		217069	217069
2	COVER & CORD (CORD - 20' (6 M) LENGTH SOW 15A PLUG)	1	2	N/A	N/A
	COVER & CORD (CORD - 20' (6 M) LENGTH SOW NO PLUG)			153109	153109
	COVER & CORD (CORD 33' (10 M) LENGTH H07RN-F3G1.5 NO PLUG/CE)			153101	153101
3	CORD, TERM & SEAL ASM (CORD - 20' (6 M) LENGTH SOW 15A PLUG)	1	2	N/A	N/A
	CORD, TERM & SEAL ASM (CORD - 20' (6 M) LENGTH SOW NO PLUG)			005391	005391
	CORD, TERM & SEAL ASM (CORD 33' (10 M) LENGTH H07RN-F3G1.5 NO PLUG)			153103	153103
4	• SEAL, CORD-ASM & STRAIN RELIEF	1	2	094032	094032
5	COVER-MACH. (CORD, SOW)	1		001077	001077
	COVER-MACH. (CORD, H07RN-F3G1.5/CE)			152044	152044
6	• GASKET, CASE/COVER	1		001011	001011
7	• WIRE PKG.	1		011092	011092
8	CAPACITOR & CLAMP ASM	1		151706	151706
9	• PLUG, TEST	2		015023	015023
10	• SEAL, THRU WALL TERM	3		003402	003402
11	HOUSING, MOTOR & STATOR	1	1	153108	153108
12	• SPRING, BEARING PRELOAD	1		017192	017192
13	• BEARING, UPPER 6201	1		006703	006703
14	ROTOR & BEARING ASM	1		018911	018911
15	• KEY	1		017893	017893
16	• BEARING, LOWER 6204	1		012544	012544
17	• SEAL, MOTOR HOUSING	1		001014	001014
18	• OIL, DIELECTRIC-(57 OZ CAN)	1		009051	009051
19	ADAPTER-MACH.	1		017891	017891
20	• SEAL, SHAFT	1		018912	018912
21	• WASHER, SEAL LOCATING & SNAP RING	1		018913	018913
22	ROTOR, PUMP-HYDRAULIC & PIN	1		018915	018915
23	• PIN	1		018992	018992
24	• SEAL, PUMP HOUSING	1		017894	017894
25	HOUSING, PUMP-MACH. & PRESS. RLF VALVE	1		019551	019551
26	LEG, WIREFORM	2		017841	017841
27	VALVE, PRESSURE RELIEF	1		018433	018433
28	STATOR, HYDRAULIC	1		151617	151617
29	• INSERT, STATOR SS	6		018369	018369
30	CUTTER & DISC ASM 810/815	1		018918	154184
31	SHIM SET	1		012632	012632
32	CLAMP, STRAIN RELIEF (CORD, SOW)	1		001770	001770
	CLAMP, STRAIN RELIEF (CORD, H07RN-F3G1.5)	1		152191	152191
33	• SCREW, .25-20 X .75 HHM-SS	4		001916	001916
34	• SCREW, #6-32 X .25 RHM SL TC STLGR	3		001877	001877
35	• SCREW, .25-20 X 1 HHM-SS	4		007790	007790
36	• SCREW, .313-18 X 2 HH CAP FULL THREAD/SS	4		018186	018186
37	• WASHER, FLAT-SS .313	4		015914	015914
38	• NUT, .313-18 H-SS	4		001813	001813
39	• WASHER, RETAINING SS	1		008533	008533
40	• SCREW, .25-20 X .75 HH SS (NYLOCK)	1		009545	009545
41	• WASHER, FLAT-SS .25	6	5	004480	N/A
42	• SCREW, .25-20 X .875 (1.125 LENGTH FOR PLATE W/O RECESS)	6		018387	153205
43	DISC, CUTTER	1		010407	153203
44	CUTTER/SHIM ASM/3 BLADE	1		019695	154185
45	RELAY	0		N/A	N/A
46	INSULATION - INSULATOR	0		N/A	N/A
47	SWITCH, FLTS - TERM & SEAL	0		N/A	N/A
48	• SEAL, CORD - FLT SWITCH	0		N/A	N/A
49	• CONNECTOR WIRENUT	0		N/A	N/A
□	REBUILD KIT			018920	018920

NOTES:

- 1) Motor housing, stator & term. (Item 11) is preassembled at the factory and must be replaced as a unit. Stator is permanently attached to the Motor Housing. Plug (Item 9) and Seal, Thru Wall Term. (Item 10) are replaceable.
- 2) If an "X" follows Model No., or Date Mfg. on brass ID tag, consult factory for ordering of this part.
- 3) See FM0160 Parts Price Sheet for listing of parts prices.
- 4) "N/A" indicates, not applicable.
- 5) Flat washers required for plate without recess.

REPLACEMENT PARTS LIST FOR MODEL "E815" MANUAL RUN OPTION

See page 7 for illustration.

REF NO.	DESCRIPTION	QTY	NOTES	MODELS:		
				E815-A	E815-B	E815-C
				4/07 thru 8/07	9/07 thru 12/07	1/08 thru 3/13
1	• HANDLE	1		217069	217069	217069
2	COVER & CORD	1	2	018927	018927	018927
3	CORD, TERM & SEAL ASM	1	2	018928	018928	018928
4	• SEAL, CORD-ASM & STRAIN RELIEF	1	2	094032	094032	094032
5	COVER-MACH.	1		001077	001077	001077
6	• GASKET, CASE/COVER	1		001011	001011	001011
7	• WIRE PKG.	1		011092	011092	011092
8	CAPACITOR & CLAMP ASM	1		010666	010666	151706
9	• PLUG, TEST	2		015023	015023	015023
10	• SEAL, THRU WALL TERM	3		003402	003402	003402
11	HOUSING, MOTOR & STATOR	1	1	018909	018909	018909
12	• SPRING, BEARING PRELOAD	1		017192	017192	017192
13	• BEARING, UPPER 6201	1		006703	006703	006703
14	ROTOR & BEARING ASM	1		018911	018911	018911
15	• KEY	1		017893	017893	017893
16	• BEARING, LOWER 6204	1		012544	012544	012544
17	• SEAL, MOTOR HOUSING	1		001014	001014	001014
18	• OIL, DIELECTRIC-(57 OZ CAN)	1		009051	009051	009051
19	ADAPTER-MACH.	1		017891	017891	017891
20	• SEAL, SHAFT	1		018912	018912	018912
21	• WASHER, SEAL LOCATING & SNAP RING	1		018913	018913	018913
22	ROTOR, PUMP-HYDRAULIC & PIN	1		018914	018915	018915
23	• PIN	1		017892	018892	018892
24	• SEAL, PUMP HOUSING	1		017894	017894	017894
25	HOUSING, PUMP-MACH. & PRESS. RLF VALVE	1		018917	018917	019551
26	LEG, WIREFORM	2		017841	017841	017841
27	VALVE, PRESSURE RELIEF	1		018433	018433	018433
28	STATOR, HYDRAULIC	1		151617	151617	151617
29	• INSERT, STATOR SS	6		018369	018369	018369
30	CUTTER & DISC ASM 810/815	1		018918	018918	018918
31	SHIM SET	1		012632	012632	012632
32	CLAMP, STRAIN RELIEF-RED	1		001770	001770	001770
33	• SCREW, .25-20 X .75 HHM-SS	4		001916	001916	001916
34	• SCREW, #6-32 X .25 RHM SL TC STLGR	4		001877	001877	001877
35	• SCREW, .25-20 X 1 HHM-SS	4		007790	007790	007790
36	• SCREW, .313-18 X 2 HH CAP FULL THREAD/SS	4		018186	018186	018186
37	• WASHER, FLAT-SS .313	4		015914	015914	015914
38	• NUT, .313-18 H-SS	4		001813	001813	001813
39	• WASHER, RETAINING SS	1		008533	008533	008533
40	• SCREW, .25-20 X .75 HH SS (NYLOCK)	1		009545	009545	009545
41	• WASHER, FLAT-SS .25	6	5	004480	004480	004480
42	• SCREW, .25-20 X 1.125	6		018387	018387	018387
43	DISC, CUTTER	1		010407	010407	010407
44	CUTTER/SHIM ASM/3 BLADE	1		019695	019695	019695
45	RELAY	1		N/A	N/A	N/A
46	INSULATION - INSULATOR	4		N/A	N/A	N/A
47	SWITCH, FLTS - TERM & SEAL	1		N/A	N/A	N/A
48	• SEAL, CORD - FLT SWITCH	1		N/A	N/A	N/A
49	• CONNECTOR WIRENUT	2		N/A	N/A	N/A
□	REBUILD KIT			018919	018920	018920

• Items included in Rebuild Kit.

□ Not Shown in Illustration.

NOTES:

- 1) Motor housing, stator & term. (Item 11) is preassembled at the factory and must be replaced as a unit. Stator is permanently attached to the Motor Housing. Plug (Item 9) and Seal, Thru Wall Term. (Item 10) are replaceable.
- 2) If an "X" follows Model No., or Date Mfg. on brass ID tag, consult factory for ordering of this part.
- 3) See FM0160 Parts Price Sheet for listing of parts prices.
- 4) "N/A" indicates, not applicable.
- 5) Flat washers required for plate without recess.

REPLACEMENT PARTS LIST FOR MODEL "RE815" MANUAL RUN OPTION

See page 7 for illustration.

REF NO.	DESCRIPTION	QTY	NOTES	MODELS:			
				RE815-A	RE815-B	RE815-C	RI815-A
				3/13 thru 1/16	2/16 thru 5/16	6/16 thru Current	4/20 thru Current
1	• HANDLE	1		217069	217069	217069	217069
2	COVER & CORD	1	2	152532	152532	152532	152532
3	CORD, TERM & SEAL ASM	1	2	152533	152533	152533	152533
4	• SEAL, CORD-ASM & STRAIN RELIEF	1	2	015634	015634	015634	015634
5	COVER-MACH.	1		014150	014150	014150	014150
6	• GASKET, CASE/COVER	1		001011	001011	001011	001011
7	• WIRE PKG.	1		004751	004751	004751	004751
8	CAPACITOR & CLAMP ASM	1		151706	151706	151706	151706
9	• PLUG, TEST	2		015023	015023	015023	015023
10	• SEAL, THRU WALL TERM	3		003402	003402	003402	003402
11	HOUSING, MOTOR & STATOR	1	1	018909	018909	018909	150961
12	• SPRING, BEARING PRELOAD	1		017192	017192	017192	017192
13	• BEARING, UPPER 6201	1		006703	006703	006703	006703
14	ROTOR & BEARING ASM	1		018911	018911	018911	018911
15	• KEY	1		017893	017893	017893	017893
16	• BEARING, LOWER 6204	1		012544	012544	012544	012544
17	• SEAL, MOTOR HOUSING	1		001014	001014	001014	001014
18	• OIL, DIELECTRIC-(57 OZ CAN)	1		009051	009051	009051	009051
19	ADAPTER-MACH.	1		017891	017891	017891	017891
20	• SEAL, SHAFT	1		018912	018912	018912	018912
21	• WASHER, SEAL LOCATING & SNAP RING	1		018913	018913	018913	018913
22	ROTOR, PUMP-HYDRAULIC & PIN	1		018915	018915	018915	018915
23	• PIN	1		018892	018892	018892	018892
24	• SEAL, PUMP HOUSING	1		017894	017894	017894	017894
25	HOUSING, PUMP-MACH. & PRESS. RLF VALVE	1		019551	019551	019551	019551
26	LEG, WIREFORM	2		017841	017841	017841	017841
27	VALVE, PRESSURE RELIEF	1		018433	018433	018433	018433
28	STATOR, HYDRAULIC	1		151617	151617	151617	151617
29	• INSERT, STATOR SS	6		018369	018369	018369	018369
30	CUTTER & DISC ASM 810/815	1		018918	018918	154184	154184
31	SHIM SET	1		012632	012632	012632	012632
32	CLAMP, STRAIN RELIEF-RED	1		013765	013765	013765	013765
33	• SCREW, .25-20 X .75 HHM-SS	4		001916	001916	001916	001916
34	• SCREW, #6-32 X .25 RHM SL TC STLGR	4		001877	001877	001877	001877
35	• SCREW, .25-20 X 1 HHM-SS	4		007790	007790	007790	007790
36	• SCREW, .313-18 X 2 HH CAP FULL THREAD/SS	4		018186	018186	018186	018186
37	• WASHER, FLAT-SS .313	4		015914	015914	015914	015914
38	• NUT, .313-18 H-SS	4		001813	001813	001813	001813
39	• WASHER, RETAINING SS	1		008533	008533	008533	008533
40	• SCREW, .25-20 X .75 HH SS (NYLOCK)	1		009545	009545	009545	009545
41	• WASHER, FLAT-SS .25	6	5	004480	004480	N/A	N/A
42	• SCREW, .25-20 X .875 (1.125 LENGTH FOR PLATE W/O RECESS)	6		018387	018387	153205	153205
43	DISC, CUTTER	1		010407	010407	153203	153203
44	CUTTER/SHIM ASM/3 BLADE	1		019695	019695	154185	154185
45	RELAY	1		217093	153833	153833	153833
46	INSULATION - INSULATOR	4		001797	001797	001797	001797
47	SWITCH, FLTS - TERM & SEAL	1		N/A	N/A	N/A	N/A
48	• SEAL, CORD - FLT SWITCH	1		N/A	N/A	N/A	N/A
49	• CONNECTOR WIRENUT	2		N/A	N/A	N/A	N/A
o	REBUILD KIT			152750	152750	152750	152750

• Items included in Rebuild Kit.

o Not Shown in Illustration.

NOTES:

- 1) Motor housing, stator & term. (Item 11) is preassembled at the factory and must be replaced as a unit. Stator is permanently attached to the Motor Housing. Plug (Item 9) and Seal, Thru Wall Term. (Item 10) are replaceable.
- 2) If an "X" follows Model No., or Date Mfg. on brass ID tag, consult factory for ordering of this part.
- 3) See FM0160 Parts Price Sheet for listing of parts prices.
- 4) "N/A" indicates, not applicable.
- 5) Flat washers required for plate without recess.

REPLACEMENT PARTS LIST FOR MODEL "RWD815" MANUAL RUN OPTION

See page 7 for illustration.

REF NO.	DESCRIPTION	QTY	NOTES	MODELS:			
				RWD815-A	RWD815-B	RWD815-C	RWH815-A
				3/15 thru 1/16	2/16 thru 5/16	6/16 thru Current	4/20 thru Current
1	• HANDLE	1		217069	217069	217069	217069
2	COVER & CORD	1	2	153382	153382	153382	153382
3	CORD, TERM & SEAL ASM	1	2	153386	153386	153386	153386
4	• SEAL, CORD-ASM & STRAIN RELIEF	1	2	015634	015634	015634	015634
5	COVER-MACH.	1		014152	014152	014152	014152
6	• GASKET, CASE/COVER	1		001011	001011	001011	001011
7	• WIRE PKG.	1		004751	004751	004751	004751
8	CAPACITOR & CLAMP ASM	1		151706	151706	151706	151706
9	• PLUG, TEST	2		015023	015023	015023	015023
10	• SEAL, THRU WALL TERM	3		003402	003402	003402	003402
11	HOUSING, MOTOR & STATOR	1	1	018909	018909	018909	150961
12	• SPRING, BEARING PRELOAD	1		017192	017192	017192	017192
13	• BEARING, UPPER 6201	1		006703	006703	006703	006703
14	ROTOR & BEARING ASM	1		018911	018911	018911	018911
15	• KEY	1		017893	017893	017893	017893
16	• BEARING, LOWER 6204	1		012544	012544	012544	012544
17	• SEAL, MOTOR HOUSING	1		001014	001014	001014	001014
18	• OIL, DIELECTRIC-(57 OZ CAN)	1		009051	009051	009051	009051
19	ADAPTER-MACH.	1		017891	017891	017891	017891
20	• SEAL, SHAFT	1		018912	018912	018912	018912
21	• WASHER, SEAL LOCATING & SNAP RING	1		018913	018913	018913	018913
22	ROTOR, PUMP-HYDRAULIC & PIN	1		018915	018915	018915	018915
23	• PIN	1		018892	018892	018892	018892
24	• SEAL, PUMP HOUSING	1		017894	017894	017894	017894
25	HOUSING, PUMP-MACH. & PRESS. RLF VALVE	1		019551	019551	019551	019551
26	LEG, WIREFORM	2		017841	017841	017841	017841
27	VALVE, PRESSURE RELIEF	1		018433	018433	018433	018433
28	STATOR, HYDRAULIC	1		151617	151617	151617	151617
29	• INSERT, STATOR SS	6		018369	018369	018369	018369
30	CUTTER & DISC ASM 810/815	1		018918	018918	154184	154184
31	SHIM SET	1		012632	012632	012632	012632
32	CLAMP, STRAIN RELIEF-RED	1		013765	013765	013765	013765
33	• SCREW, .25-20 X .75 HHM-SS	4		001916	001916	001916	001916
34	• SCREW, #6-32 X .25 RHM SL TC STLGR	4		001877	001877	001877	001877
35	• SCREW, .25-20 X 1 HHM-SS	4		007790	007790	007790	007790
36	• SCREW, .313-18 X 2 HH CAP FULL THREAD/SS	4		018186	018186	018186	018186
37	• WASHER, FLAT-SS .313	4		015914	015914	015914	015914
38	• NUT, .313-18 H-SS	4		001813	001813	001813	001813
39	• WASHER, RETAINING SS	1		008533	008533	008533	008533
40	• SCREW, .25-20 X .75 HH SS (NYLOCK)	1		009545	009545	009545	009545
41	• WASHER, FLAT-SS .25	6	5	004480	004480	N/A	N/A
42	• SCREW, .25-20 X .875 (1.125 LENGTH FOR PLATE W/O RECESS)	6		018387	018387	153205	153205
43	DISC, CUTTER	1		010407	010407	153203	153203
44	CUTTER/SHIM ASM/3 BLADE	1		019695	019695	154185	154185
45	RELAY	1		217093	153833	153833	153833
46	INSULATION - INSULATOR	4		001797	001797	001797	001797
47	SWITCH, FLTS - TERM & SEAL	1		153383	153383	153383	153383
48	• SEAL, CORD - FLT SWITCH	1		094043	094043	094043	094043
49	• CONNECTOR WIRENUT	2		003753	003753	003753	003753
□	REBUILD KIT			152750	152750	152750	152750

- Items included in Rebuild Kit.
- Not Shown in Illustration.

NOTES:

- 1) Motor housing, stator & term. (Item 11) is preassembled at the factory and must be replaced as a unit. Stator is permanently attached to the Motor Housing. Plug (Item 9) and Seal, Thru Wall Term. (Item 10) are replaceable.
- 2) If an "X" follows Model No., or Date Mfg. on brass ID tag, consult factory for ordering of this part.
- 3) See FM0160 Parts Price Sheet for listing of parts prices.
- 4) "N/A" indicates, not applicable.
- 5) Flat washers required for plate without recess.

REPLACEMENT PARTS ILLUSTRATION FOR 815 - ALL MODELS

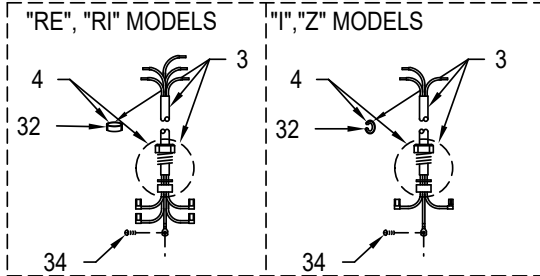
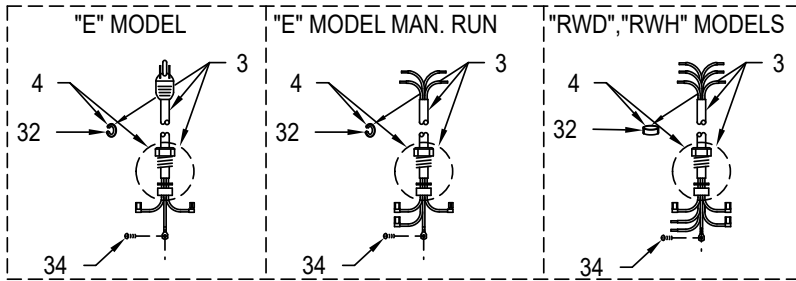

APPLICABLE CORD, SWITCH,
SEALS AND GROUND SCREW

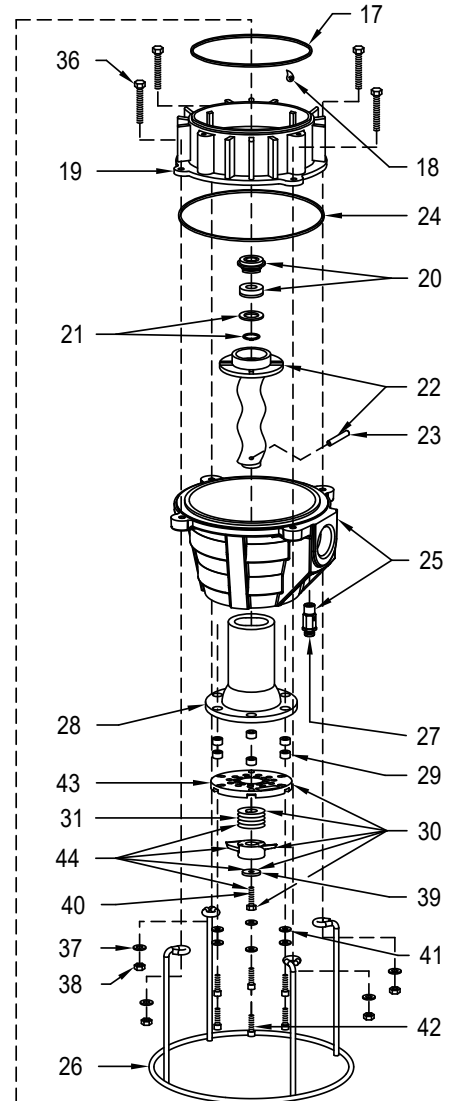
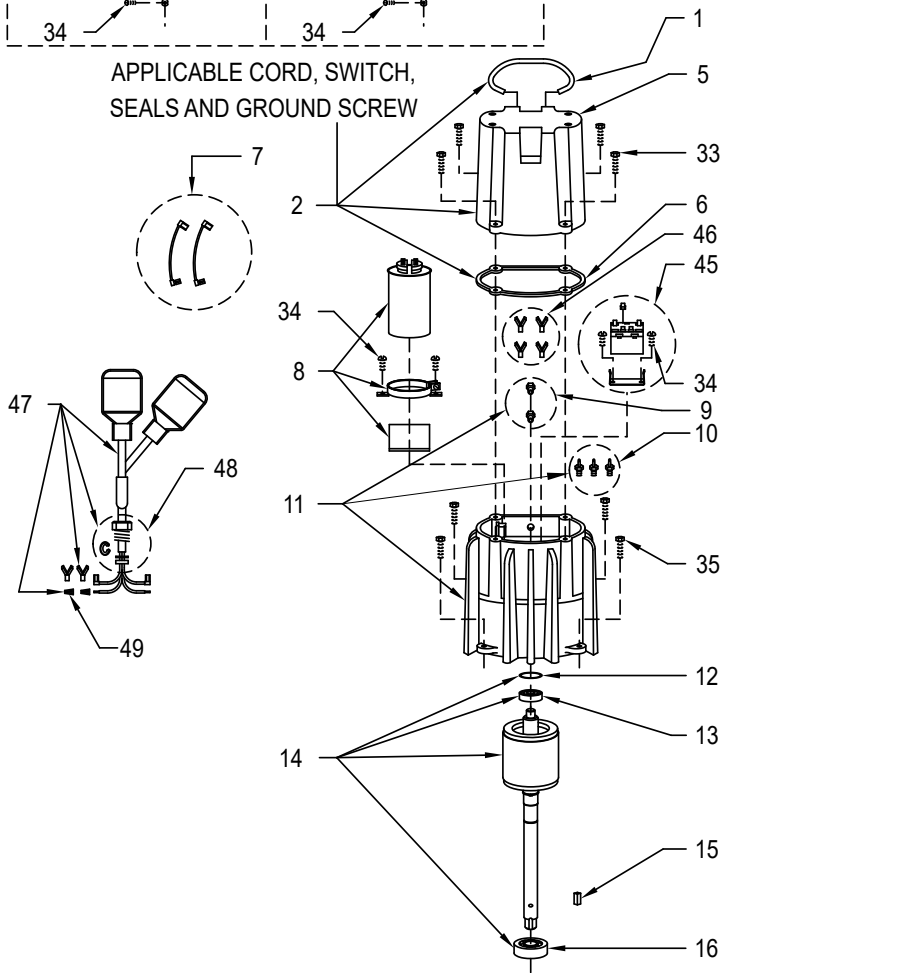

SK2653

NOTES



MAIL TO: P.O. BOX 16347 • Louisville, KY 40256-0347
SHIP TO: 3649 Cane Run Road • Louisville, KY 40211-1961
(502) 778-2731 • 1 (800) 928-PUMP • FAX (502) 774-3624

Visit our website:
zoellerpumps.com

Trusted. Tested. Tough.®

© Copyright 2020 Zoeller® Co. All rights reserved.