

Product information presented here reflects conditions at time of publication. Consult factory regarding discrepancies or inconsistencies.

MAIL TO: P.O. BOX 16347 • Louisville, KY 40256-0347
 SHIP TO: 3649 Cane Run Road • Louisville, KY 40211-1961
 TEL: (502) 778-2731 • 1 (800) 928-PUMP • FAX: (502) 774-3624

Visit our website:
 zoellerpumps.com

REPLACEMENT PARTS LIST FOR GRINDER MODELS:

E810 NONAUTOMATIC 230V 1PH
 RE810 NONAUTOMATIC/MANUAL RUN 230V 1PH
 RWD810 AUTOMATIC/MANUAL RUN W/ WIRED FLOAT SWITCH 230V 1PH

Consult factory for all other models.

**TO ORDER REPLACEMENT PARTS
 PLEASE FURNISH THE FOLLOWING INFORMATION:**

- Model number
- Part number of pump
- Part number and description of part

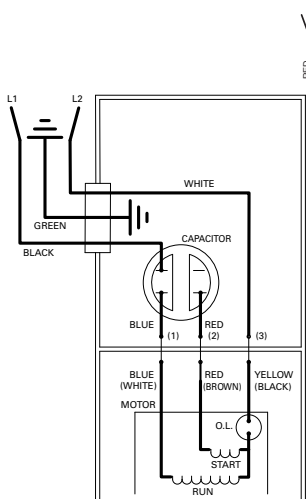

002397

WIRING DIAGRAM FOR MODELS
 "E810-A" and "E810-B"
 8/06 thru Current

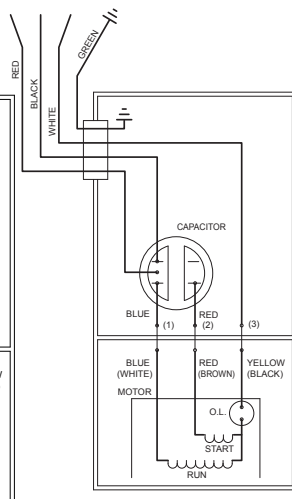

018929

WIRING DIAGRAM FOR MODELS
 "E810-A" and "E810-B"
 Manual Run Option
 4/07 thru 3/13

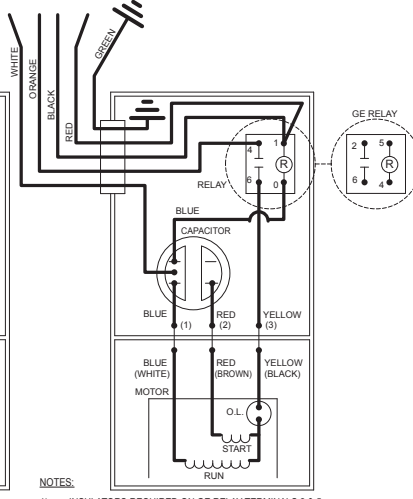

152554

WIRING DIAGRAM FOR MODEL
 RE810
 3/13 thru Current

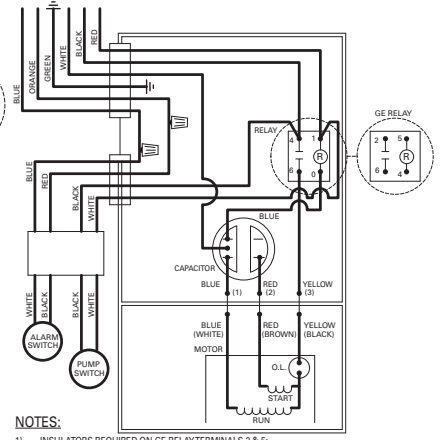

153381

WIRING DIAGRAM FOR MODEL
 RWD810
 All revisions thru Current

NOTES:
 1) INSULATORS REQUIRED ON GE RELAY TERMINALS 2 & 5;
 OMRON RELAY TERMINALS 1 & 4.

NOTES:
 1) INSULATORS REQUIRED ON GE RELAY TERMINALS 2 & 5;
 OMRON RELAY TERMINALS 1 & 4.

REPLACEMENT PARTS LIST FOR MODEL "E810"

See page 6 for illustration.

REF NO.	DESCRIPTION	QTY	NOTES	MODELS:			
				E810-A	E810-B	E810-C	E810-D
				8/06 thru 8/07	9/07 thru 12/07	1/08 thru 5/16	6/16 thru Current
1	• HANDLE	1		217069	217069	217069	217069
2	COVER & CORD	1	2	002401	002401	002401	002401
3	CORD, TERM & SEAL ASM	1	2	002402	002402	002402	002402
4	• SEAL, CORD-ASM & STR RLF	1	2	094032	094032	094032	094032
5	COVER-MACH.	1		001077	001077	001077	001077
6	• GASKET, CASE/COVER	1		001011	001011	001011	001011
7	• WIRE PKG.	1		011092	011092	011092	011092
8	CAPACITOR & CLAMP ASM	1		006135	006135	006135	006135
9	• PLUG, TEST	2		015023	015023	015023	015023
10	• SEAL, THRU WALL TERM	3		003402	003402	003402	003402
11	HOUSING, MTR-& STR	1	1	018908	018908	018908	018908
12	• SPRING, BEARING PRELOAD	1		017192	017192	017192	017192
13	• BEARING, UPPER 6201	1		006703	006703	006703	006703
14	ROTOR & BRG ASM	1		018910	018910	018910	018910
15	• KEY	1		017893	017893	017893	017893
16	• BEARING, LOWER 6204	1		012544	012544	012544	012544
17	• SEAL, MTR HSG	1		001014	001014	001014	001014
18	• OIL, DIELECTRIC-(57 OZ CAN)	1		009051	009051	009051	009051
19	ADAPTER-MACH.	1		017891	017891	017891	017891
20	• SEAL, SHAFT	1		018912	018912	018912	018912
21	• WASHER, SEAL LOCATING & SNAP RING	1		018913	018913	018913	018913
22	ROTOR, PUMP-HYDRAULIC & PIN	1		018914	018915	018915	018915
23	• PIN	1		017892	018892	018892	018892
24	• SEAL, PUMP HOUSING	1		017894	017894	017894	017894
25	HOUSING, PUMP-MACH. & PRESS. RLF VALVE	1		018916	018916	019550	019550
26	LEG, WIREFORM	2		017841	017841	017841	017841
27	VALVE, PRESSURE RELIEF	1		018432	018432	018432	018432
28	STATOR, HYDRAULIC	1		151617	151617	151617	151617
29	• INSERT, STATOR SS	6		018369	018369	018369	018369
30	CUTTER & DISC ASM 810/815	1		018918	018918	018918	154184
31	SHIM SET	1		012632	012632	012632	012632
32	CLAMP, STRAIN RELIEF-RED	1		152191	152191	152191	152191
33	• SCREW, .25-20 X .75 HHM-SS	4		001916	001916	001916	001916
34	• SCREW, #6-32 X .25 RHM SL TC STLGR	3		001877	001877	001877	001877
35	• SCREW, .25-20 X 1 HHM-SS	4		007790	007790	007790	007790
36	• SCREW, .313-18 X 2 HH CAP FULL THREAD/SS	4		018186	018186	018186	018186
37	• WASHER, FLAT-SS .313	4		015914	015914	015914	015914
38	• NUT, .313-18 H-SS	4		001813	001813	001813	001813
39	• WASHER, RETAINING SS	1		008533	008533	008533	008533
40	• SCREW, .25-20 X .75 HH SS (NYLOCK)	1		009545	009545	009545	009545
41	• WASHER, FLAT-SS .25	6	5	004480	004480	004480	N/A
42	• SCREW, .25-20 X .875 (1.125 LENGTH FOR PLATE W/O RECESS)	6		018387	018387	018387	153205
43	DISC, CUTTER	1		010407	010407	010407	153203
44	CUTTER/SHIM ASM	1		019695	019695	019695	154185
45	RELAY	0		N/A	N/A	N/A	N/A
46	INSULATION - INSULATOR	0		N/A	N/A	N/A	N/A
47	SWITCH, FLTS - TERM & SEAL	1		N/A	N/A	N/A	N/A
48	• SEAL, CORD - FLT SWITCH	1		N/A	N/A	N/A	N/A
49	• CONNECTOR WIRENUT	2		N/A	N/A	N/A	N/A
□	REBUILD KIT			018919	018920	018920	018920

• Items included in Rebuild Kit.

□ Not Shown in Illustration.

NOTES:

- 1) Mtr. Hsg, Stator & Term. (Item 11) is preassembled at the factory and must be replaced as a unit. Stator is permanently attached to the Motor Housing. Plug (Item 9) and Seal, Thru Wall Term. (Item 10) are replaceable.
- 2) If an "X" follows Model No., or Date Mfg. on brass ID tag, consult factory for ordering of this part.
- 3) See FM0160 Parts Price Sheet for listing of parts prices.
- 4) "N/A" indicates, not applicable.
- 5) Flat washers required for plate without recess.

REPLACEMENT PARTS LIST FOR MODEL "E810" MANUAL RUN OPTION

See page 6 for illustration.

REF NO.	DESCRIPTION	QTY	NOTES	MODELS:		
				E810-A	E810-B	E810-C
				4/07 thru 8/07	9/07 thru 12/07	1/08 thru 3/13
1	• HANDLE	1		217069	217069	217069
2	COVER & CORD	1	2	018927	018927	018927
3	CORD, TERM & SEAL ASM	1	2	018928	018928	018928
4	• SEAL, CORD-ASM & STR RLF	1	2	094032	094032	094032
5	COVER-MACH.	1		001077	001077	001077
6	• GASKET, CASE/COVER	1		001011	001011	001011
7	• WIRE PKG.	1		011092	011092	011092
8	CAPACITOR & CLAMP ASM	1		006135	006135	006135
9	• PLUG, TEST	2		015023	015023	015023
10	• SEAL, THRU WALL TERM	3		003402	003402	003402
11	HOUSING, MTR-& STR	1	1	018908	018908	018908
12	• SPRING, BEARING PRELOAD	1		017192	017192	017192
13	• BEARING, UPPER 6201	1		006703	006703	006703
14	ROTOR & BRG ASM	1		018910	018910	018910
15	• KEY	1		017893	017893	017893
16	• BEARING, LOWER 6204	1		012544	012544	012544
17	• SEAL, MTR HSG	1		001014	001014	001014
18	• OIL, DIELECTRIC-(57 OZ CAN)	1		009051	009051	009051
19	ADAPTER-MACH.	1		017891	017891	017891
20	• SEAL, SHAFT	1		018912	018912	018912
21	• WASHER, SEAL LOCATING & SNAP RING	1		018913	018913	018913
22	ROTOR, PUMP-HYDRAULIC & PIN	1		018914	018915	018915
23	• PIN	1		017892	018892	018892
24	• SEAL, PUMP HOUSING	1		017894	017894	017894
25	HOUSING, PUMP-MACH. & PRESS. RLF VALVE	1		018916	018916	019550
26	LEG, WIREFORM	2		017841	017841	017841
27	VALVE, PRESSURE RELIEF	1		018432	018432	018432
28	STATOR, HYDRAULIC	1		151617	151617	151617
29	• INSERT, STATOR SS	6		018369	018369	018369
30	CUTTER & DISC ASM 810/815	1		018918	018918	018918
31	SHIM SET	1		012632	012632	012632
32	CLAMP, STRAIN RELIEF	1		001770	001770	001770
33	• SCREW, .25-20 X .75 HHM-SS	4		001916	001916	001916
34	• SCREW, #6-32 X .25 RHM SL TC STLGR	4		001877	001877	001877
35	• SCREW, .25-20 X 1 HHM-SS	4		007790	007790	007790
36	• SCREW, .313-18 X 2 HH CAP FULL THREAD/SS	4		018186	018186	018186
37	• WASHER, FLAT-SS .313	4		015914	015914	015914
38	• NUT, .313-18 H-SS	4		001813	001813	001813
39	• WASHER, RETAINING SS	1		008533	008533	008533
40	• SCREW, .25-20 X .75 HH SS (NYLOCK)	1		009545	009545	009545
41	• WASHER, FLAT-SS .25	6	5	004480	004480	004480
42	• SCREW, .25-20 X .875 (1.125 LENGTH FOR PLATE W/O RECESS)	6		018387	018387	018387
43	DISC, CUTTER	1		010407	010407	010407
44	CUTTER/SHIM ASM	1		019695	019695	019695
45	RELAY	1		N/A	N/A	N/A
46	INSULATION - INSULATOR	4		N/A	N/A	N/A
47	SWITCH, FLTS - TERM & SEAL	1		N/A	N/A	N/A
48	• SEAL, CORD - FLT SWITCH	1		N/A	N/A	N/A
49	• CONNECTOR WIRENUT	2		N/A	N/A	N/A
□	REBUILD KIT			018919	018920	018920

• Items included in Rebuild Kit.

□ Not Shown in Illustration.

NOTES:

- 1) Mtr. Hsg, Stator & Term. (Item 11) is preassembled at the factory and must be replaced as a unit. Stator is permanently attached to the Motor Housing. Plug (Item 9) and Seal, Thru Wall Term. (Item 10) are replaceable.
- 2) If an "X" follows Model No., or Date Mfg. on brass ID tag, consult factory for ordering of this part.
- 3) See FM0160 Parts Price Sheet for listing of parts prices.
- 4) "N/A" indicates, not applicable.
- 5) Flat washers required for plate without recess.

REPLACEMENT PARTS LIST FOR MODEL "RE810" MANUAL RUN OPTION

See page 6 for illustration.

REF NO.	DESCRIPTION	QTY	NOTES	MODELS:		
				RE810	RE810-B	RE810-C
				3/13 thru 1/16	2/16 thru 5/16	6/16 thru Current
1	• HANDLE	1		217069	217069	217069
2	COVER & CORD	1	2	152532	152532	152532
3	CORD, TERM & SEAL ASM	1	2	152533	152533	152533
4	• SEAL, CORD-ASM & STR RLF	1	2	015634	015634	015634
5	COVER-MACH.	1		014150	014150	014150
6	• GASKET, CASE/COVER	1		001011	001011	001011
7	• WIRE PKG.	1		004751	004751	004751
8	CAPACITOR & CLAMP ASM	1		006135	006135	006135
9	• PLUG, TEST	2		015023	015023	015023
10	• SEAL, THRU WALL TERM	3		003402	003402	003402
11	HOUSING, MTR-& STR	1	1	018908	018908	018908
12	• SPRING, BEARING PRELOAD	1		017192	017192	017192
13	• BEARING, UPPER 6201	1		006703	006703	006703
14	ROTOR & BRG ASM	1		018910	018910	018910
15	• KEY	1		017893	017893	017893
16	• BEARING, LOWER 6204	1		012544	012544	012544
17	• SEAL, MTR HSG	1		001014	001014	001014
18	• OIL, DIELECTRIC-(57 OZ CAN)	1		009051	009051	009051
19	ADAPTER-MACH.	1		017891	017891	017891
20	• SEAL, SHAFT	1		018912	018912	018912
21	• WASHER, SEAL LOCATING & SNAP RING	1		018913	018913	018913
22	ROTOR, PUMP-HYDRAULIC & PIN	1		018915	018915	018915
23	• PIN	1		018892	018892	018892
24	• SEAL, PUMP HOUSING	1		017894	017894	017894
25	HOUSING, PUMP-MACH. & PRESS. RLF VALVE	1		019550	019550	019550
26	LEG, WIREFORM	2		017841	017841	017841
27	VALVE, PRESSURE RELIEF	1		018432	018432	018432
28	STATOR, HYDRAULIC	1		151617	151617	151617
29	• INSERT, STATOR SS	6		018369	018369	018369
30	CUTTER & DISC ASM 810/815	1		018918	018918	154184
31	SHIM SET	1		012632	012632	012632
32	CLAMP, STRAIN RELIEF	1		013765	013765	013765
33	• SCREW, .25-20 X .75 HHM-SS	4		001916	001916	001916
34	• SCREW, #6-32 X .25 RHM SL TC STLGR	4		001877	001877	001877
35	• SCREW, .25-20 X 1 HHM-SS	4		007790	007790	007790
36	• SCREW, .313-18 X 2 HH CAP FULL THREAD/SS	4		018186	018186	018186
37	• WASHER, FLAT-SS .313	4		015914	015914	015914
38	• NUT, .313-18 H-SS	4		001813	001813	001813
39	• WASHER, RETAINING SS	1		008533	008533	008533
40	• SCREW, .25-20 X .75 HH SS (NYLOCK)	1		009545	009545	009545
41	• WASHER, FLAT-SS .25	6	5	004480	004480	N/A
42	• SCREW, .25-20 X .875 (1.125 LENGTH FOR PLATE W/O RECESS)	6		018387	018387	153205
43	DISC, CUTTER	1		010407	010407	153203
44	CUTTER/SHIM ASM	1		019695	019695	154185
45	RELAY	1		217093	153833	153833
46	INSULATION - INSULATOR	4		001797	001797	001797
47	SWITCH, FLTS - TERM & SEAL	1		N/A	N/A	N/A
48	• SEAL, CORD - FLT SWITCH	1		N/A	N/A	N/A
49	• CONNECTOR WIRENUT	2		N/A	N/A	N/A
α	REBUILD KIT			152750	152750	152750

• Items included in Rebuild Kit.

α Not Shown in Illustration.

NOTES:

- 1) Mtr. Hsg, Stator & Term. (Item 11) is preassembled at the factory and must be replaced as a unit. Stator is permanently attached to the Motor Housing. Plug (Item 9) and Seal, Thru Wall Term. (Item 10) are replaceable.
- 2) If an "X" follows Model No., or Date Mfg. on brass ID tag, consult factory for ordering of this part.
- 3) See FM0160 Parts Price Sheet for listing of parts prices.
- 4) "N/A" indicates, not applicable.
- 5) Flat washers required for plate without recess.

REPLACEMENT PARTS LIST FOR MODEL "RWD810" MANUAL RUN OPTION

See page 6 for illustration.

REF NO.	DESCRIPTION	MODELS:		RWD810-A	RWD810-B	RWD810-C
		QTY	NOTES	3/15 thru 1/16	2/16 thru 5/16	6/16 thru Current
1	• HANDLE	1		217069	217069	217069
2	COVER & CORD	1	2	153382	153382	153382
3	CORD, TERM & SEAL ASM	1	2	153386	153386	153386
4	• SEAL, CORD-ASM & STR RLF	1	2	015634	015634	015634
5	COVER-MACH.	1		014152	014152	014152
6	• GASKET, CASE/COVER	1		001011	001011	001011
7	• WIRE PKG.	1		004751	004751	004751
8	CAPACITOR & CLAMP ASM	1		006135	006135	006135
9	• PLUG, TEST	2		015023	015023	015023
10	• SEAL, THRU WALL TERM	3		003402	003402	003402
11	HOUSING, MTR-& STR	1	1	018908	018908	018908
12	• SPRING, BEARING PRELOAD	1		017192	017192	017192
13	• BEARING, UPPER 6201	1		006703	006703	006703
14	ROTOR & BRG ASM	1		018910	018910	018910
15	• KEY	1		017893	017893	017893
16	• BEARING, LOWER 6204	1		012544	012544	012544
17	• SEAL, MTR HSG	1		001014	001014	001014
18	• OIL, DIELECTRIC-(57 OZ CAN)	1		009051	009051	009051
19	ADAPTER-MACH.	1		017891	017891	017891
20	• SEAL, SHAFT	1		018912	018912	018912
21	• WASHER, SEAL LOCATING & SNAP RING	1		018913	018913	018913
22	ROTOR, PUMP-HYDRAULIC & PIN	1		018915	018915	018915
23	• PIN	1		018892	018892	018892
24	• SEAL, PUMP HOUSING	1		017894	017894	017894
25	HOUSING, PUMP-MACH. & PRESS. RLF VALVE	1		019550	019550	019550
26	LEG, WIREFORM	2		017841	017841	017841
27	VALVE, PRESSURE RELIEF	1		018432	018432	018432
28	STATOR, HYDRAULIC	1		151617	151617	151617
29	• INSERT, STATOR SS	6		018369	018369	018369
30	CUTTER & DISC ASM 810/815	1		018918	018918	154184
31	SHIM SET	1		012632	012632	012632
32	CLAMP, STRAIN RELIEF	1		013765	013765	013765
33	• SCREW, .25-20 X .75 HHM-SS	4		001916	001916	001916
34	• SCREW, #6-32 X .25 RHM SL TC STLGR	4		001877	001877	001877
35	• SCREW, .25-20 X 1 HHM-SS	4		007790	007790	007790
36	• SCREW, .313-18 X 2 HH CAP FULL THREAD/SS	4		018186	018186	018186
37	• WASHER, FLAT-SS .313	4		015914	015914	015914
38	• NUT, .313-18 H-SS	4		001813	001813	001813
39	• WASHER, RETAINING SS	1		008533	008533	008533
40	• SCREW, .25-20 X .75 HH SS (NYLOCK)	1		009545	009545	009545
41	• WASHER, FLAT-SS .25	6	5	004480	004480	N/A
42	• SCREW, .25-20 X .875 (1.125 LENGTH FOR PLATE W/O RECESS)	6		018387	018387	153205
43	DISC, CUTTER	1		010407	010407	153203
44	CUTTER/SHIM ASM	1		019695	019695	154185
45	RELAY	1		217093	153833	153833
46	INSULATION - INSULATOR	4		001797	001797	001797
47	SWITCH, FLTS - TERM & SEAL	1		153383	153383	153383
48	• SEAL, CORD - FLT SWITCH	1		094043	094043	094043
49	• CONNECTOR WIRENUT	2		003753	003753	003753
□	REBUILD KIT			152750	152750	152750

• Items included in Rebuild Kit.

□ Not Shown in Illustration.

NOTES:

- 1) Mtr. Hsg, Stator & Term. (Item 11) is preassembled at the factory and must be replaced as a unit. Stator is permanently attached to the Motor Housing. Plug (Item 9) and Seal, Thru Wall Term. (Item 10) are replaceable.
- 2) If an "X" follows Model No., or Date Mfg. on brass ID tag, consult factory for ordering of this part.
- 3) See FM0160 Parts Price Sheet for listing of parts prices.
- 4) "N/A" indicates, not applicable.
- 5) Flat washers required for plate without recess.

REPLACEMENT PARTS ILLUSTRATION FOR 810 - ALL MODELS

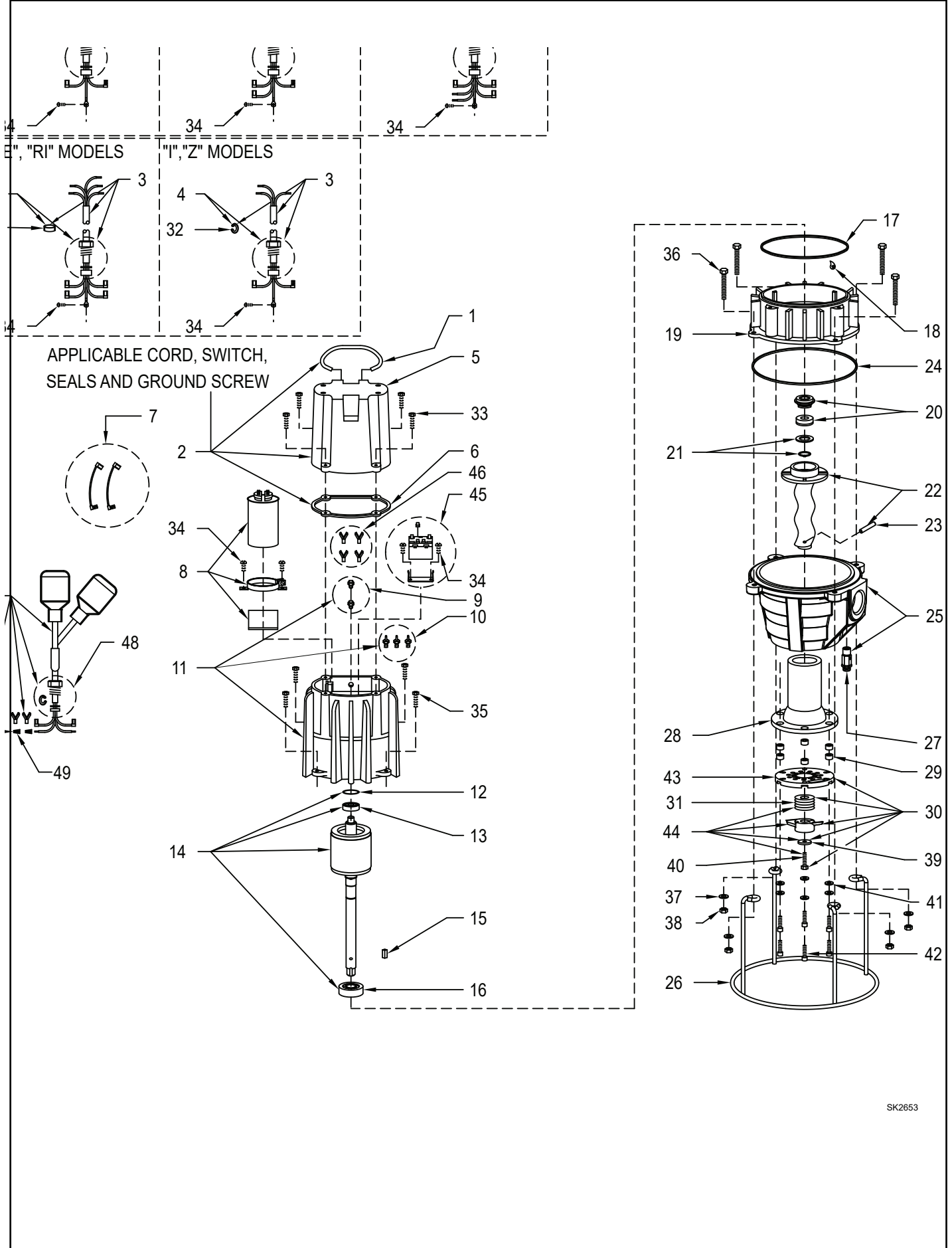

SK2653

NOTES

A large, empty rectangular box with a thin black border, occupying most of the page. It is intended for the user to write their notes.

NOTES



MAIL TO: P.O. BOX 16347 • Louisville, KY 40256-0347
SHIP TO: 3649 Cane Run Road • Louisville, KY 40211-1961
(502) 778-2731 • 1 (800) 928-PUMP • FAX (502) 774-3624

Visit our website:
zoellerpumps.com

Trusted. Tested. Tough.®

© Copyright 2021 Zoeller® Co. All rights reserved.