

Trusted. Tested. Tough.®



SECTION: 2.45.040

FM2124

0823

Supersedes

0523

MAIL TO: P.O. BOX 16347 • Louisville, KY 40256-0347
SHIP TO: 3649 Cane Run Road • Louisville, KY 40211-1961
Tel: (502) 778-2731 • 1 (800) 928-PUMP

Visit our website:
zoellerpumps.com

Product information presented here reflects conditions at time of publication. Consult factory regarding discrepancies or inconsistencies.

PREASSEMBLED SUMP PUMP SYSTEMS 900 SERIES

Job ready for a fast and easy installation.
No assembly required - Drop it in the hole-and-go!

900 SUMP PUMP SERIES INCLUDES:

Preassembled:

- Pump switch is installed 180° from inlet.
- Discharge pipe is plumbed with a predrilled 3/16" vent hole.
- Electrical cord seal is installed in cover.
- Cover is sealed and bolted down.
- Basin is filled with environmentally safe peanuts for safe transit - just add water and they dissolve!
- Automatic cast iron or thermoplastic pump with tank and all hardware.
- 18" X 22" basin with 4" inlet
- Deluxe unit has a radon-approved basin and cover for radon prevention.
- Standard model uses a polyethylene basin and cover.
- Deluxe cover has a 3" vent, 1-1/2" discharge.
- Standard cover has a 2" vent, 1-1/2" discharge.
- Fast, easy and job ready!



* Vent pipe not included.

SUMP PUMP SERIES	MODEL PUMP WITH BASIN	SYSTEM TYPE	SYSTEM WEIGHT
900-0001	M53*	DELUXE	48 LBS.
900-0002	M53*	STANDARD	53 LBS.

ALL MODELS ARE
COMPLETELY SUBMERSIBLE
HERMETICALLY SEALED

Watertight - dust tight. Permanently oiled bearings.

* Pump powered by Zoeller Motor Works motor

**DELUXE & STANDARD SYSTEMS
(Model M53 Pump)**

- Automatic, float operated mechanical switch
- 115 V/1 Ph., 60 Hz.
- 9 ft. UL Listed 3-wire cord and plug
- Stainless steel screws, guard, handle and switch arm
- Passes 1/2" spherical solids
- 1-1/2" NPT discharge
- 1550 RPM
- Non-clogging vortex impeller
- Glass-filled polypropylene base with built-in strainer
- Temperature rated 130 °F
- UL and CSA Listed Pump

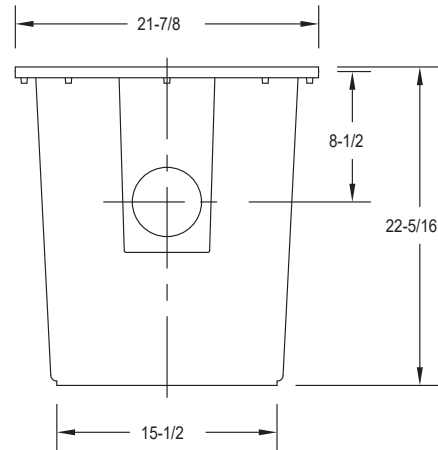
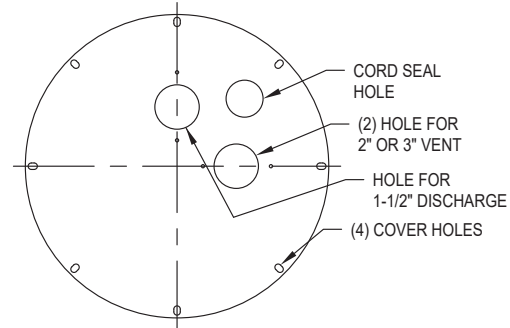

SK2297

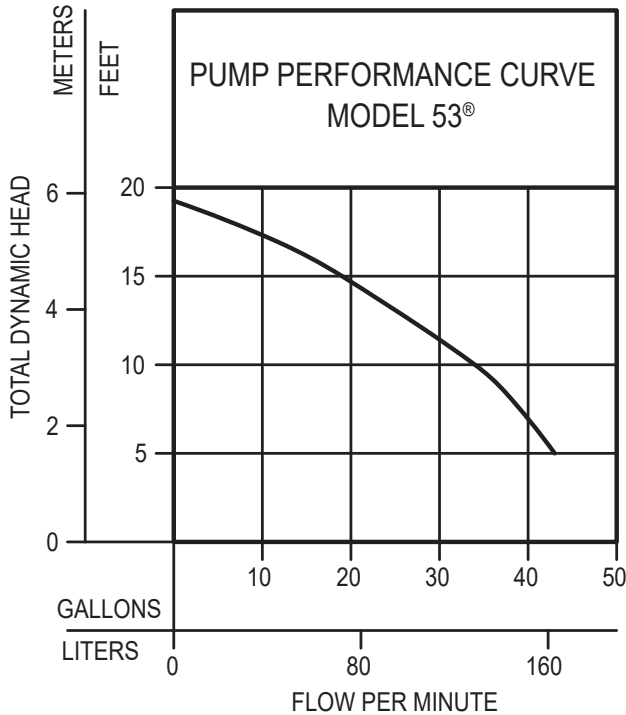

009897

**TOTAL DYNAMIC HEAD/FLOW
PER MINUTE
EFFLUENT AND DEWATERING**

MODEL		53	
Feet	Meters	Gal.	Liters
5	1.5	43	163
10	3.0	34	129
15	4.6	19	72
Shut-off Head:		19.25 ft.(5.9m)	

009897

JOB READY FOR EASY INSTALLATION

⚠ WARNING TO REDUCE THE RISK OF ELECTRICAL SHOCK A PROPERLY GROUNDED RECEPTACLE OF GROUNDTING TYPE SHALL BE INSTALLED AND PROTECTED BY A GROUND FAULT CIRCUIT INTERRUPTER (GFCI) IN ACCORDANCE WITH NATIONAL ELECTRICAL CODE AND LOCAL CODES. DO NOT REMOVE GROUND PIN FROM PLUG.

RESERVE POWERED DESIGN

For unusual conditions a reserve safety factor is engineered into the design of every Zoeller pump.