

MAIL TO: P.O. BOX 16347 • Louisville, KY 40256-0347
SHIP TO: 3649 Cane Run Road • Louisville, KY 40211-1961
Tel: (502) 778-2731 • 1 (800) 928-PUMP

Visit our website:
zoellerpumps.com

Product information presented here reflects conditions at time of publication. Consult factory regarding discrepancies or inconsistencies.

REPLACEMENT PARTS LIST FOR GRINDER MODELS:

E820 NONAUTOMATIC 230V 1PH
I820 NONAUTOMATIC 200V 1PH
WD820 AUTOMATIC w/wired float switch 230V 1PH
WH820 AUTOMATIC w/wired float switch 200V 1PH
J820 NONAUTOMATIC 200 V 3PH (Obsolete as of 10/1/2023)
F820 NONAUTOMATIC 230 V 3PH (Obsolete as of 10/1/2023)
G820 NONAUTOMATIC 460 V 3PH (Obsolete as of 10/1/2023)
BA820 NONAUTOMATIC 575 V 3PH (Obsolete as of 10/1/2023)

Consult factory for all other models

TO ORDER REPLACEMENT PARTS:

PLEASE FURNISH THE FOLLOWING INFORMATION:

- Model Number.
- Part Number of Pump.
- Part Number and Description of part.

NOTE: NEW WIRING FOR OLDER REVISION PUMPS. REWIRE PUMP JUNCTION BOX CHAMBER (TOP CAP) PER APPROPRIATE WIRING DIAGRAM BELOW.

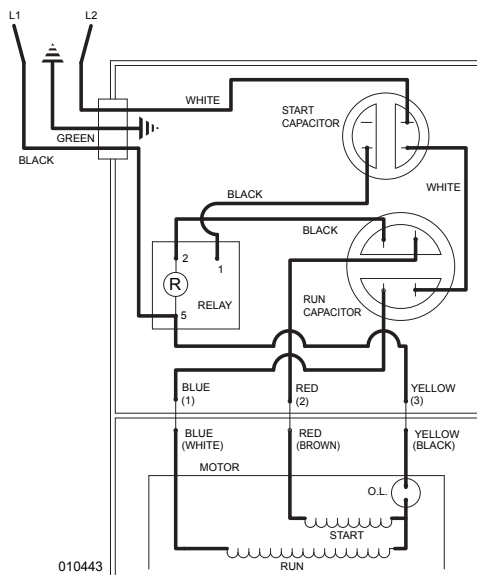

WIRING DIAGRAM FOR MODELS
"E820" All Revisions and
"I820" All Revisions
9/96 thru Current

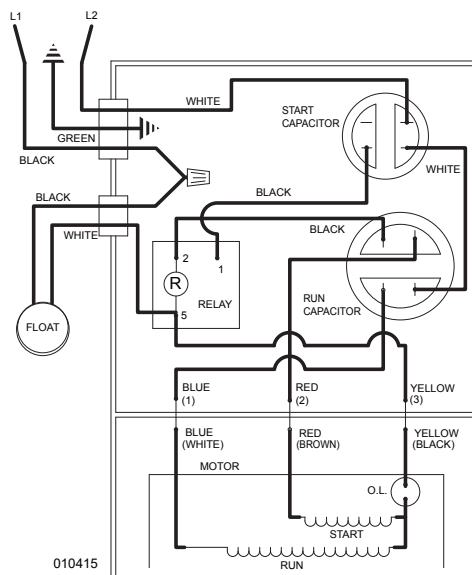

WIRING DIAGRAM FOR MODELS
"WD820" All Revisions and
"WH820" All Revisions
9/96 thru Current

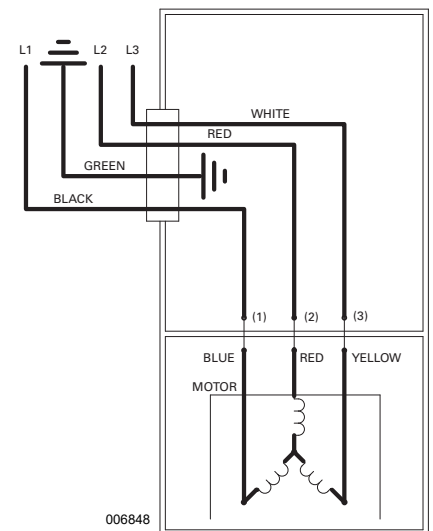

WIRING DIAGRAM FOR MODELS
"J820", "F820", "G820"
and "BA820" All Revisions
09/17 thru 10/23

REPLACEMENT PARTS LIST FOR MODEL "E820".

See page 7 for illustration.

REF NO.	DESCRIPTION	QTY	NOTE	MODELS:						
				E820-A	E820-B	E820-C	E820-D	E820-E	E820-F	
				9/96 thru 12/97	1/98 thru 8/02	9/02 thru 4/06	5/06 thru 9/08	10/08 thru 1/17	2/17 thru Current	
1	• HANDLE	1		217069	217069	217069	217069	217069	217069	
2	COVER & CORD 200/230V/1PH/NONAUTO/"820"	1	3	010836	010836	015608	015608	015608	015608	
3	COVER-MACH & HANDLE ASM	1	3	010835	010835	015612	015612	015612	015612	
4	SWITCH,FLT-TERM & SEAL "820"	0		N/A	N/A	N/A	N/A	N/A	N/A	
5	SEAL,CORD-FLOAT SWITCH	0		N/A	N/A	N/A	N/A	N/A	N/A	
6	CORD TERM&SEAL	1	3	010840	010840	015614	015614	015614	015614	
7	• SEAL,CORD-ASM&STR RLF	1	3	004375	004375	015634	015634	015634	015634	
8	• GASKET,CASE/COVER	1		001011	001011	001011	001011	001011	001011	
9	• WIRE PKG (6 WIRES)	1		010833	010833	010833	010833	010833	010833	
10	CAPACITOR-START & CLAMP ASM.	1		010829	010829	010829	010829	010829	010829	
11	CAPACITOR-RUN & CLAMP ASM	1		010830	010830	010830	010830	010830	010830	
12	RELAY,VOLTAGE SENSING	1		010410	014601	014601	014601	014601	014601	
13	• PLUG,TEST	2		015023	015023	015023	015023	015023	015023	
14	• SEAL,THRU WALL TERM	3		003402	003402	003402	003402	003402	003402	
15	HOUSING,MTR-&STR	1	4	010444	010444	010444	018231	018231	018231	
16	BEARING,SLEEVE-BRONZE OILITE	1		001012	001012	001012	N/A	N/A	N/A	
	• BEARING,6201			N/A	N/A	N/A	006703	006703	006703	
17	KEY	1		007775	011711	011711	011711	011711		
18	ROTOR & BRG ASM/1PH "820"	1		010831	010831	010831	018230	018230	018230	
19	• BEARING,7303	1		009861	009861	009861	009861	009861	009861	
20	• SEAL,MTR HSG	1		001014	001014	001014	001014	001014	001014	
21	• OIL,DIELECTRIC	1		010839	010839	010839	018233	018233	018233	
22	ADAPTER-MACH	1		001003	001003	001003	001003	001003	001003	
23	• SEAL,SHAFT	1		002430	002430	002430	002430	002430	002430	
24	WASHER,SUPPORT-SS	1		010863	010863	010863	010863	010863	010863	
25	COLLAR,SHAFT	1		010409	010409	010409	010409	010409	010409	
26	IMPELLER-MACH "820"	1		010402	010402	010402	010402	N/A	N/A	
	IMPELLER-PLASTIC "820"			N/A	N/A	N/A	N/A	019358	019358	
27	HOUSING,PUMP-MACH "820"	1		010400	010400	010400	010400	010400	154088	
28	CUTTER & DISC ASM./"820"	1		010832	010832	010832	010832	010832	154292	
29	GRINDER SHIM SET	1		012632	012632	012632	012632	012632	012632	
30	WASHER,RETAINING	1		008533	008533	008533	008533	008533	008533	
31	GUARD,CUTTER-PLASTIC	1		008528	008528	008528	008528	008528	N/A	
32	CONNECTOR,WIRENUT 14-16GA	0		N/A	N/A	N/A	N/A	N/A	N/A	
33	• SCREW,.25-.20X.75" SH CAP SS.	3		007768	007768	007768	007768	007768	N/A	
	• SCREW,.25-.20X.75" SH CAP SS.	6		N/A	N/A	N/A	N/A	N/A	007768	
34	• SCREW,.25-.20 X .75LG HH SS (NYLOCK)	1		009545	009545	009545	009545	009545	009545	
35	• SCREW,#10-24X.875-FLT SH CAP SS.	3		007761	007761	007761	007761	007761	N/A	
36	• SCREW,.313-18 X 1" HH CAP-SS	4		002608	002608	002608	002608	002608	002608	
37	• SCREW,.25-.20X1" HHM-S.S.	4		007790	007790	007790	007790	007790	007790	
38	• SCREW,.25-.20X.75 HHM-SS/INDENTED/UNSLOT	4		001916	001916	001916	001916	001916	001916	
39	• SCREW,#6-32X.25RHM SL TC STLGR	5		001877	001877	001877	001877	001877	001877	
40	• SPRING,BEARING PRELOAD	1		N/A	N/A	N/A	017192	017192	017192	
41	• WASHER,FLAT-SS .25 STANDARD	3		004480	004480	004480	004480	004480	N/A	
42	• SCREW,#6-32X.375RHM SL TC ZINC PLATED	1		019421	019421	019421	019421	019421	019421	
43	DISC, CUTTER	1		010407	010407	010407	010407	010407	153203	
44	CUTTER & SHIM ASM	1		019697	019697	019697	019697	019697	154295	
45	INSULATOR FLAG TERMINAL	3		001797	001797	001797	001797	001797	001797	
o	REBUILD KIT E & I "820"/820"	1		010844	010844	015804	018234	018234	018234	

- Items included in Rebuild Kit.
- ◻ Not Shown in Illustration.

NOTES:

- 1) See FM0160 Price Sheet for listing of parts prices.
- 2) "N/A" indicates, not applicable.
- 3) If an "X" follows Model No., or Date Mfg. on brass ID tag, consult factory for ordering of this part.
- 4) Housing, MTR & Stator (Item 15) is preassembled at factory and must be replaced as a unit. Stator is permanently attached to the Motor Housing. Plug (Item 13) and Seal, thru Wall Term. (Item 14) and Bearing (Item 16) are replaceable.

REPLACEMENT PARTS LIST FOR MODEL "I820".

See page 7 for illustration.

REF NO.	DESCRIPTION	QTY	NOTE	MODELS:						
				I820-A	I820-B	I820-C	I820-D	I820-E	I820-F	
				9/96 thru 12/97	1/98 thru 8/02	9/02 thru 4/06	5/06 thru 9/08	10/08 thru 1/17	2/17 thru Current	
1	• HANDLE	1		217069	217069	217069	217069	217069	217069	
2	COVER & CORD 200/230V/1PH/NONAUTO/"820"	1	3	010838	010838	015609	015609	015609	015609	
3	COVER-MACH & HANDLE ASM	1	3	010835	010835	015612	015612	015612	015612	
4	SWITCH,FLT-TERM & SEAL "820"	0		N/A	N/A	N/A	N/A	N/A	N/A	
5	SEAL,CORD-FLOAT SWITCH	0		N/A	N/A	N/A	N/A	N/A	N/A	
6	CORD TERM&SEAL	1	3	010841	010841	015615	015615	015615	015615	
7	• SEAL,CORD-ASM&STR RLF	1	3	004375	004375	015634	015634	015634	015634	
8	• GASKET,CASE/COVER	1		001011	001011	001011	001011	001011	001011	
9	• WIRE PKG (6 WIRES)	1		010833	010833	010833	010833	010833	010833	
10	CAPACITOR-START & CLAMP ASM.	1		010829	010829	010829	010829	010829	010829	
11	CAPACITOR-RUN & CLAMP ASM	1		010830	010830	010830	010830	010830	010830	
12	RELAY,VOLTAGE SENSING	1		010410	014601	014601	014601	014601	014601	
13	• PLUG,TEST	2		015023	015023	015023	015023	015023	015023	
14	• SEAL,THRU WALL TERM	3		003402	003402	003402	003402	003402	003402	
15	HOUSING,MTR-&STR	1	4	010449	010449	010449	018232	018232	018232	
16	BEARING,SLEEVE-BRONZE OILITE	1		001012	001012	001012	N/A	N/A	N/A	
	• BEARING,6201			N/A	N/A	N/A	006703	006703	006703	
17	KEY	1		007775	011711	011711	011711	011711	011711	
18	ROTOR & BRG ASM/1PH "820"	1		010831	010831	010831	018230	018230	018230	
19	• BEARING,7303	1		009861	009861	009861	009861	009861	009861	
20	• SEAL,MTR HSG	1		001014	001014	001014	001014	001014	001014	
21	• OIL,DIELECTRIC	1		010839	010839	010839	018233	018233	018233	
22	ADAPTER-MACH	1		001003	001003	001003	001003	001003	001003	
23	• SEAL,SHAFT	1		002430	002430	002430	002430	002430	002430	
24	WASHER,SUPPORT-SS	1		010863	010863	010863	010863	010863	010863	
25	COLLAR,SHAFT	1		010409	010409	010409	010409	010409	010409	
26	IMPELLER-MACH "820"	1		010402	010402	010402	010402	N/A	N/A	
	IMPELLER-PLASTIC "820"			N/A	N/A	N/A	N/A	019358	019358	
27	HOUSING,PUMP-MACH "820"	1		010400	010400	010400	010400	010400	154088	
28	CUTTER & DISC ASM,/"820"	1		010832	010832	010832	010832	010832	154292	
29	GRINDER SHIM SET	1		012632	012632	012632	012632	012632	012632	
30	WASHER,RETAINING	1		008533	008533	008533	008533	008533	008533	
31	GUARD,CUTTER-PLASTIC	1		008528	008528	008528	008528	008528	N/A	
32	CONNECTOR,WIRENUT 14-16GA	0		N/A	N/A	N/A	N/A	N/A	N/A	
33	• SCREW,.25-.20X.75" SH CAP SS.	3		007768	007768	007768	007768	007768	N/A	
	• SCREW,.25-.20X.75" SH CAP SS.	6		N/A	N/A	N/A	N/A	N/A	007768	
34	• SCREW,.25-.20 X .75LG HH SS (NYLOCK)	1		009545	009545	009545	009545	009545	009545	
35	• SCREW,#10-24X.875-FLT SH CAP SS.	3		007761	007761	007761	007761	007761	N/A	
36	• SCREW,.313-18 X 1" HH CAP-SS	4		002608	002608	002608	002608	002608	002608	
37	• SCREW,.25-.20X1" HHM-S.S.	4		007790	007790	007790	007790	007790	007790	
38	• SCREW,.25-.20X.75 HHM-SS/INDENTED/UNSLOT	4		001916	001916	001916	001916	001916	001916	
39	• SCREW,#6-32X.25RHM SL TC STLGR	5		001877	001877	001877	001877	001877	001877	
40	• SPRING,BEARING PRELOAD	1		N/A	N/A	N/A	017192	017192	017192	
41	• WASHER,FLAT-SS .25 STANDARD	3		004480	004480	004480	004480	004480	N/A	
42	• SCREW,#6-32X.375RHM SL TC ZINC PLATED	1		019421	019421	019421	019421	019421	019421	
43	DISC, CUTTER	1		010407	010407	010407	010407	010407	153203	
44	CUTTER & SHIM ASM	1		019697	019697	019697	019697	019697	154295	
45	INSULATOR FLAG TERMINAL	3		001797	001797	001797	001797	001797	001797	
□	REBUILD KIT E & I "820"/820"	1		010844	010844	015804	018234	018234	018234	

- Items included in Rebuild Kit.
- Not Shown in Illustration.

NOTES:

- 1) See FM0160 Price Sheet for listing of parts prices.
- 2) "N/A" indicates, not applicable.
- 3) If an "X" follows Model No., or Date Mfg. on brass ID tag, consult factory for ordering of this part.
- 4) Housing, MTR & Stator (Item 15) is preassembled at factory and must be replaced as a unit. Stator is permanently attached to the Motor Housing. Plug (Item 13) and Seal, thru Wall Term. (Item 14) and Bearing (Item 16) are replaceable.

REPLACEMENT PARTS LIST FOR MODEL "WD820".

See page 7 for illustration.

REF NO.	DESCRIPTION	QTY	NOTE	MODELS:					
				WD820-A	WD820-B	WD820-C	WD820-D	WD820-E	WD820-F
				9/96 thru 12/97	1/98 thru 8/02	9/02 thru 4/06	5/06 thru 9/08	10/08 thru 1/17	2/17 thru Current
1	• HANDLE	1		217069	217069	217069	217069	217069	217069
2	COVER,CORD & FLT	1		010825	010825	015610	015610	015610	015610
3	COVER-MACH & HANDLE ASM	1	3	010826	010826	015613	015613	015613	015613
4	SWITCH,FLT-TERM & SEAL "820"	1	3	010827	010827	010827	010827	010827	010827
5	• SEAL,CORD-FLOAT SWITCH	1		011065	011065	011065	011065	011065	011065
6	CORD TERM & SEAL	1	3	010828	010828	015632	015632	015632	015632
7	• SEAL,CORD-ASM&STR RLF	1	3	004375	004375	015634	015634	015634	015634
8	• GASKET,CASE/COVER	1		001011	001011	001011	001011	001011	001011
9	• WIRE PKG (6 WIRES)	1		010833	010833	010833	010833	010833	010833
10	CAPACITOR-START & CLAMP ASM.	1		010829	010829	010829	010829	010829	010829
11	CAPACITOR-RUN & CLAMP ASM	1		010830	010830	010830	010830	010830	010830
12	RELAY,VOLTAGE SENSING	1		010410	014601	014601	014601	014601	014601
13	• PLUG,TEST	2		015023	015023	015023	015023	015023	015023
14	• SEAL,THRU WALL TERM	3		003402	003402	003402	003402	003402	003402
15	HOUSING,MTR-&STR	1	4	010444	010444	010444	018231	018231	018231
16	BEARING,SLEEVE-BRONZE OILITE	1		001012	001012	001012	N/A	N/A	N/A
	• BEARING,6201			N/A	N/A	N/A	006703	006703	006703
17	KEY	1		007775	011711	011711	011711	011711	
18	ROTOR & BRG ASM/1PH "820"	1		010831	010831	010831	018230	018230	018230
19	• BEARING,7303	1		009861	009861	009861	009861	009861	009861
20	• SEAL,MTR HSG	1		001014	001014	001014	001014	001014	001014
21	• OIL,DIELECTRIC	1		010839	010839	010839	018233	018233	018233
22	ADAPTER-MACH	1		001003	001003	001003	001003	001003	001003
23	• SEAL,SHAFT	1		002430	002430	002430	002430	002430	002430
24	WASHER,SUPPORT-SS	1		010863	010863	010863	010863	010863	010863
25	COLLAR,SHAFT	1		010409	010409	010409	010409	010409	010409
26	IMPELLER-MACH "820"	1		010402	010402	010402	010402	N/A	N/A
	IMPELLER-PLASTIC "820"			N/A	N/A	N/A	N/A	019358	019358
27	HOUSING,PUMP-MACH "820"	1		010400	010400	010400	010400	010400	154088
28	CUTTER & DISC ASM,/"820"	1		010832	010832	010832	010832	010832	154292
29	GRINDER SHIM SET	1		012632	012632	012632	012632	012632	012632
30	WASHER,RETAINING	1		008533	008533	008533	008533	008533	008533
31	GUARD,CUTTER-PLASTIC	1		008528	008528	008528	008528	008528	N/A
32	• CONNECTOR,WIRENUT 14-16GA	1		003753	003753	003753	003753	003753	003753
33	• SCREW,.25-20X.75"SH CAP SS.	3		007768	007768	007768	007768	007768	N/A
	• SCREW,.25-20X.75"SH CAP SS.	6		N/A	N/A	N/A	N/A	N/A	007768
34	• SCREW,.25-20 X .75LG HH SS (NYLC)	1		009545	009545	009545	009545	009545	009545
35	• SCREW,#10-24X.875-FLT SH CAP SS.	3		007761	007761	007761	007761	007761	N/A
36	• SCREW,.313-18 X 1"HH CAP-SS	4		002608	002608	002608	002608	002608	002608
37	• SCREW,.25-20X1" HHM-S.S.	4		007790	007790	007790	007790	007790	007790
38	• SCREW,.25-20X.75 HHM-SS/ INDENTED/UNSLOTTED	4		001916	001916	001916	001916	001916	001916
39	• SCREW,#6-32X.25RHM SL TC STLGR	5		001877	001877	001877	001877	001877	001877
40	• SPRING,BEARING PRELOAD	1		N/A	N/A	N/A	017192	017192	017192
41	• WASHER,FLAT-SS .25 STANDARD	3		004480	004480	004480	004480	004480	N/A
42	• SCREW,#6-32X.375RHM SLTC ZINC	1		019421	019421	019421	019421	019421	019421
43	DISC, CUTTER	1		010407	010407	010407	010407	010407	153203
44	CUTTER/SHIM ASM	1		019697	019697	019697	019697	019697	154295
45	INSULATOR FLAG TERMINAL	3		001797	001797	001797	001797	001797	001797
o	REBUILD KIT WD & WH "820/6820"	1		010843	010843	015803	018234	018234	018234

• Items included in Rebuild Kit.

o Not Shown in Illustration.

NOTES:

- 1) See FM0160 Price Sheet for listing of parts prices.
- 2) "N/A" indicates, not applicable.
- 3) If an "X" follows Model No., or Date Mfg. on brass ID tag, consult factory for ordering of this part.
- 4) Housing, MTR & Stator (Item 15) is preassembled at factory and must be replaced as a unit. Stator is permanently attached to the Motor Housing. Plug (Item 13) and Seal, thru Wall Term. (Item 14) and Bearing (Item 16) are replaceable.

REPLACEMENT PARTS LIST FOR MODEL "WH820".

See page 7 for illustration.

REF NO.	DESCRIPTION	QTY	NOTE	MODELS:						
				WH820-A	WH820-B	WH820-C	WH820-D	WH820-E	WH820-F	WH820-G
				9/96 thru 12/97	1/98 thru 10/98	11/98 thru 8/02	9/02 thru 4/06	5/06 thru 9/08	10/08 thru 1/17	2/17 thru Current
1	• HANDLE	1		217069	217069	217069	217069	217069	217069	217069
2	COVER, CORD & FLT	1		010837	010837	010837	015611	015611	015611	015611
3	COVER-MACH & HANDLE ASM	1	3	010826	010826	010826	015613	015613	015613	015613
4	SWITCH, FLT-TERM & SEAL "820"	1	3	010827	010827	011880	011880	011880	011880	011880
5	• SEAL, CORD-FLOAT SWITCH	1		011065	011065	011071	011071	011071	011071	011071
6	CORD TERM & SEAL	1	3	010842	010842	010842	015633	015633	015633	015633
7	• SEAL, CORD-ASM&STR RLF	1	3	004375	004375	004375	015634	015634	015634	015634
8	• GASKET, CASE/COVER	1		001011	001011	001011	001011	001011	001011	001011
9	• WIRE PKG (6 WIRES)	1		010833	010833	010833	010833	010833	010833	010833
10	CAPACITOR-START & CLAMP ASM.	1		010829	010829	010829	010829	010829	010829	010829
11	CAPACITOR-RUN & CLAMP ASM	1		010830	010830	010830	010830	010830	010830	010830
12	RELAY, VOLTAGE SENSING	1		010410	010410	014601	014601	014601	014601	014601
13	• PLUG, TEST	2		015023	015023	015023	015023	015023	015023	015023
14	• SEAL, THRU WALL TERM	3		003402	003402	003402	003402	003402	003402	003402
15	HOUSING, MTR-&STR	1	4	010449	010449	010449	010449	018232	018232	018232
16	BEARING, SLEEVE-BRONZE OILITE	1		001012	001012	001012	001012	N/A	N/A	N/A
	• BEARING, 6201			N/A	N/A	N/A	N/A	006703	006703	006703
17	KEY	1		007775	011711	011711	011711	011711	011711	011711
18	ROTOR & BRG ASM/1PH "820"	1		010831	010831	010831	010831	018230	018230	018230
19	• BEARING, 7303	1		009861	009861	009861	009861	009861	009861	009861
20	• SEAL, MTR HSG	1		001014	001014	001014	001014	001014	001014	001014
21	• OIL, DIELECTRIC	1		010839	010839	010839	010839	018233	018233	018233
22	ADAPTER-MACH	1		001003	001003	001003	001003	001003	001003	001003
23	• SEAL, SHAFT	1		002430	002430	002430	002430	002430	002430	002430
24	WASHER, SUPPORT-SS	1		010863	010863	010863	010863	010863	010863	010863
25	COLLAR, SHAFT	1		010409	010409	010409	010409	010409	010409	010409
26	IMPELLER-MACH "820"	1		010402	010402	010402	010402	010402	N/A	N/A
	IMPELLER-PLASTIC "820"			N/A	N/A	N/A	N/A	N/A	019358	019358
27	HOUSING, PUMP-MACH "820"	1		010400	010400	010400	010400	010400	010400	154088
28	CUTTER & DISC ASM, "820"	1		010832	010832	010832	010832	010832	010832	154292
29	GRINDER SHIM SET	1		012632	012632	012632	012632	012632	012632	012632
30	WASHER, RETAINING	1		008533	008533	008533	008533	008533	008533	008533
31	GUARD, CUTTER-PLASTIC	1		008528	008528	008528	008528	008528	008528	N/A
32	• CONNECTOR, WIRENUT 14-16GA	1		003753	003753	003753	003753	003753	003753	003753
33	• SCREW, .25-.20X.75" SH CAP SS.	3		007768	007768	007768	007768	007768	007768	N/A
	• SCREW, .25-.20X.75" SH CAP SS.	6		N/A	N/A	N/A	N/A	N/A	N/A	007768
34	• SCREW, .25-.20 X .75LG HH SS (NYLC)	1		009545	009545	009545	009545	009545	009545	009545
35	• SCREW, #10-24X.875-FLT SH CAP SS.	3		007761	007761	007761	007761	007761	007761	N/A
36	• SCREW, .313-18 X 1" HH CAP-SS	4		002608	002608	002608	002608	002608	002608	002608
37	• SCREW, .25-.20X1" HHM-S.S.	4		007790	007790	007790	007790	007790	007790	007790
38	• SCREW, .25-.20X.75 HHM-SS/ INDENTED/UNSLOTTED	4		001916	001916	001916	001916	001916	001916	001916
39	• SCREW, #6-32X.25RHM SLTC STLGR	5		001877	001877	001877	001877	001877	001877	001877
40	• SPRING, BEARING PRELOAD	1		N/A	N/A	N/A	N/A	017192	017192	017192
41	• WASHER, FLAT-SS .25 STANDARD	3		004480	004480	004480	004480	004480	004480	N/A
42	• SCREW, #6-32X.375RHM SLTC ZINC	1		019421	019421	019421	019421	019421	019421	019421
43	DISC, CUTTER	1		010407	010407	010407	010407	010407	010407	153203
44	CUTTER/SHIM ASM	1		019697	019697	019697	019697	019697	019697	154295
45	INSULATOR FLAG TERMINAL	3		001797	001797	001797	001797	001797	001797	001797
o	REBUILD KIT WD & WH "820/6820"	1		010843	010843	010843	015803	018234	018234	018234

- Items included in Rebuild Kit.
- o Not Shown in Illustration.

NOTES:

- 1) See FM0160 Price Sheet for listing of parts prices.
- 2) "N/A" indicates, not applicable.
- 3) If an "X" follows Model No., or Date Mfg. on brass ID tag, consult factory for ordering of this part.
- 4) Housing, MTR & Stator (Item 15) is preassembled at factory and must be replaced as a unit. Stator is permanently attached to the Motor Housing. Plug (Item 13) and Seal, thru Wall Term. (Item 14) and Bearing (Item 16) are replaceable.

REPLACEMENT PARTS LIST FOR MODELS “J820”, “F820”, “G820”, & “BA820”. See page 7 for illustration.

REF NO.	DESCRIPTION	QTY	NOTE	MODELS:			
				J820-A	F820-A	G820-A	BA820-A
				09/17 thru 10/23	09/17 thru 10/23	09/17 thru 10/23	09/17 thru 10/23
1	• HANDLE	1		217069	217069	217069	217069
2	COVER AND CORD 3PH/NOAUTO '820"	1		154685	154685	154685	154685
3	COVER-MACH & HANDLE ASM	1		015612	015612	015612	015612
4	SWITCH, FLT-TERM & SEAL	0		N/A	N/A	N/A	N/A
5	SEAL, CORD-FLOAT SWITCH	0		N/A	N/A	N/A	N/A
6	CORD TERM & SEAL	1		014177	014177	014177	014177
7	• SEAL, CORD-ASM & STR RLF	1		015634	015634	015634	015634
8	• GASKET, CASE/COVER	1		001011	001011	001011	001011
9	• WIRE PKG (6 WIRES)	0		N/A	N/A	N/A	N/A
10	CAPACITOR-START & CLAMP ASM	0		N/A	N/A	N/A	N/A
11	CAPACITOR-RUN & CLAMP ASM	0		N/A	N/A	N/A	N/A
12	RELAY, VOLTAGE SENSING	0		N/A	N/A	N/A	N/A
13	• PLUG, TEST	2		015023	015023	015023	015023
14	• SEAL, THRU WALL TERM	3		003402	003402	003402	003402
15	HOUSING, MTR & STR	1	4	154676	154677	154679	154670
16	BEARING, SLEEVE-BRONZE OILITE	1		N/A	N/A	N/A	N/A
	• BEARING, 6201			006703	006703	006703	006703
17	KEY	1		011711	011711	011711	011711
18	ROTOR & BRG ASM 3PH '820"	1		154698	154698	154698	154698
19	• BEARING, 7303	1		009861	009861	009861	009861
20	• SEAL, MTR HSG	1		001014	001014	001014	001014
21	• OIL, DIELECTRIC	1		018233	018233	018233	018233
22	ADAPTER-MACH	1		001003	001003	001003	001003
23	• SEAL, SHAFT	1		002430	002430	002430	002430
24	WASHER, SUPPORT-SS	1		010863	010863	010863	010863
25	COLLAR, SHAFT	1		010409	010409	010409	010409
26	IMPELLER-MACH	1		N/A	N/A	N/A	N/A
	IMPELLER-PLASTIC '820"			019358	019358	019358	019358
27	HOUSING, PUMP-MACH '820"	1		154088	154088	154088	154088
28	CUTTER & DISC ASM '820"	1		154292	154292	154292	154292
29	CUTTER SHIM SET	1		012632	012632	012632	012632
30	WASHER, RETAINING	1		008533	008533	008533	008533
31	GUARD, CUTTER-PLASTIC	0		N/A	N/A	N/A	N/A
32	CONNECTOR, WIRENUT 14-16GA	0		N/A	N/A	N/A	N/A
33	• SCREW, .25-20 X .75" SH CAP SS	6		007768	007768	007768	007768
34	• SCREW, .25-20 X .75" HH SS (NYLOCK)	1		009545	009545	009545	009545
35	• SCREW, #10-24 X .875-FLT SH CAP SS	0		N/A	N/A	N/A	N/A
36	• SCREW, .313-18 X 1" HH CAP SS	4		002608	002608	002608	002608
37	• SCREW, .25-20 X 1" HHM SS	4		007790	007790	007790	007790
38	• SCREW, .25-20 X .75" HHM SS/INDENTED/UNSLLOT	4		001916	001916	001916	001916
39	• SCREW, #6-32X.25RHM SL TC STLGR	1		001877	001877	001877	001877
40	• SPRING, BEARING PRELOAD	1		017192	017192	017192	017192
41	• WASHER, FLAT-SS .25 STANDARD	0		N/A	N/A	N/A	N/A
42	• SCREW, #6-32 X .375 RHM SL TC ZINC PLATED	0		N/A	N/A	N/A	N/A
43	DISC, CUTTER	1		153203	153203	153203	153203
44	CUTTER & SHIM ASM/2 BLADE/.75" SCREW	1		154295	154295	154295	154295
45	INSULATOR FLAG TERMINAL	0		N/A	N/A	N/A	N/A
	REBUILD KIT	1		018234	018234	018234	018234

- Items included in Rebuild Kit.
- ◻ Not Shown in Illustration.

NOTES:

- 1) See FM0160 Price Sheet for listing of parts prices.
- 2) "N/A" indicates, not applicable.
- 3) If an "X" follows Model No., or Date Mfg. on brass ID tag, consult factory for ordering of this part.
- 4) Housing, MTR & Stator (Item 15) is preassembled at factory and must be replaced as a unit. Stator is permanently attached to the Motor Housing. Plug (Item 13) and Seal, thru Wall Term. (Item 14) and Bearing (Item 16) are replaceable.

REPLACEMENT PARTS ILLUSTRATION FOR 820 - ALL MODELS

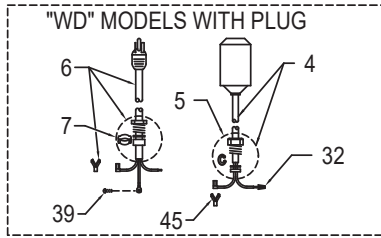
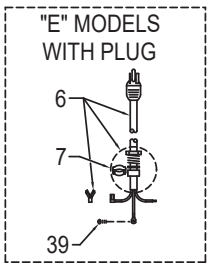

APPLICABLE CORD, SEAL & GROUND SCREW

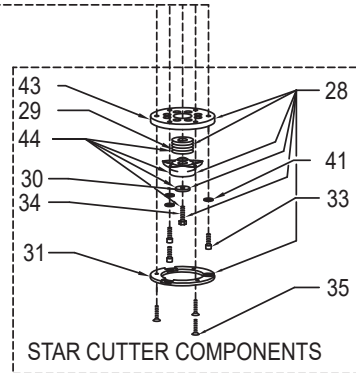
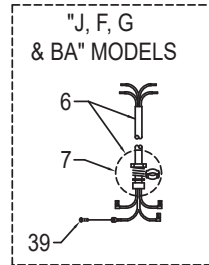
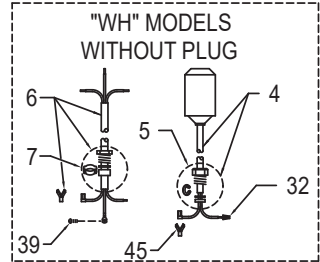
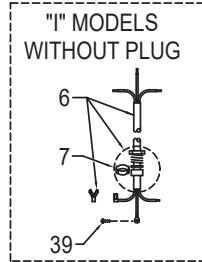
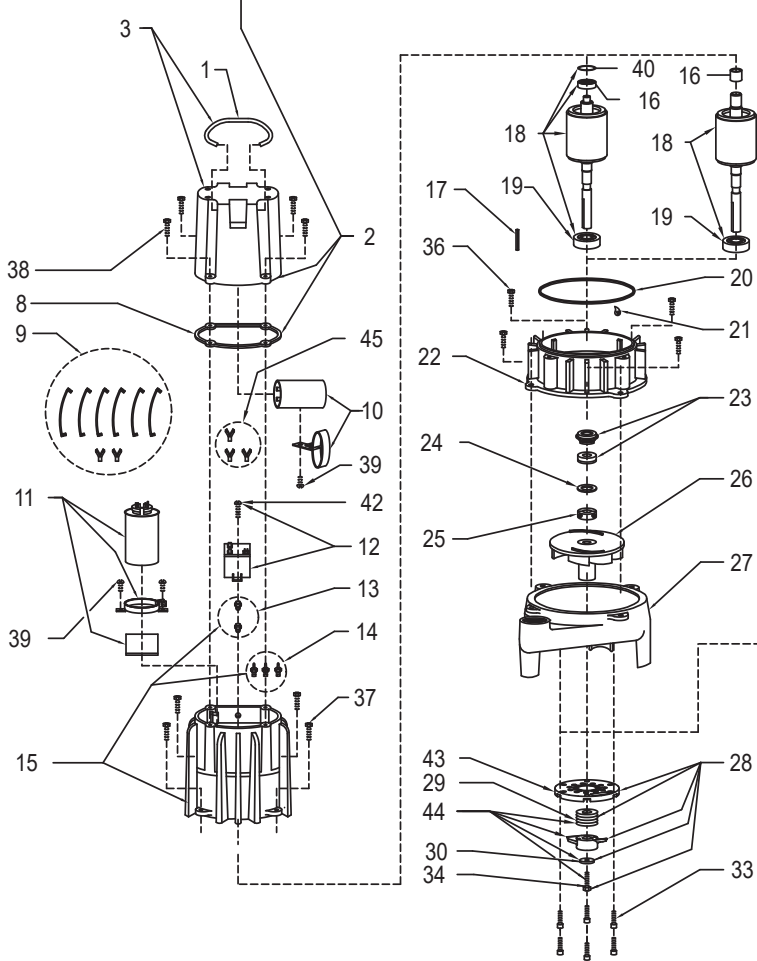

NOTES



MAIL TO: P.O. BOX 16347 • Louisville, KY 40256-0347
SHIP TO: 3649 Cane Run Road • Louisville, KY 40211-1961
Tel: (502) 778-2731 • 1 (800) 928-PUMP

Trusted. Tested. Tough.®

Visit our website:
zoellerpumps.com