

Trusted. Tested. Tough.®



FM0937
0223
Supersedes
1017

Product information presented here reflects conditions at time of publication. Consult factory regarding discrepancies or inconsistencies.

Register your
Zoeller Pump Company
Product on our website:
<http://reg.zoellerpumps.com/>



MAIL TO: P.O. BOX 16347 • Louisville, KY 40256-0347
SHIP TO: 3649 Cane Run Road • Louisville, KY 40211-1961
Tel: (502) 778-2731 • 1 (800) 928-PUMP

Visit our website:
zoellerpumps.com



OWNER'S MANUAL

NOTICE TO INSTALLER: Instructions must remain with installation.

MODEL 404/4404 AND 405/4405

Congratulations on the purchase of the Zoeller 400/4400 series submersible pump. For over fifty years the name Zoeller has represented the standard for submersible sump and sewage pumps. The same high quality workmanship and easy maintenance design has been incorporated into this line of heavy-duty solids-handling submersible sewage pumps. This Zoeller pump will provide years of trouble-free service when installed according to the manufacturers' recommendations.

This manual incorporates the installation, operation, maintenance, and service instructions into one document to aid in the ownership of a Zoeller submersible sewage product. Please read and review this manual before installing the product. Many items contained within, when followed correctly, will not only ensure a long and problem-free life for the pump, but also save time and money during installation. Should further assistance be necessary please call our Technical Service Department at 1-800-928-PUMP.

Table of Contents

Safety Instructions	1
Limited Warranty	2
Service Checklist	2
Preinstallation Information.....	3
Pump Performance Data	4
Typical Dewatering Installation	4
Typical Sewage Installation	4
Pump Wiring Instructions.....	5
Operation.....	6
Maintenance	6
Replacement Parts	7

Owner's Information

Model Number: _____ Date Code: _____

Simplex Panel P/N _____

Duplex Rail System P/N _____

Job Name: _____

Dealer: _____

Date of Purchase: _____

Contractor: _____

Date of Installation: _____

System Readings During Operation: Voltage _____ Amps _____

Safety Instructions

TO AVOID SERIOUS OR FATAL PERSONAL INJURY OR MAJOR PROPERTY DAMAGE, READ AND FOLLOW ALL SAFETY INSTRUCTIONS IN MANUAL AND ON PUMP.

THIS MANUAL IS INTENDED TO ASSIST IN THE INSTALLATION AND OPERATION OF THIS UNIT AND MUST BE KEPT WITH THE PUMP.



This is a SAFETY ALERT SYMBOL.

When you see this symbol on the pump or in the manual, look for one of the following signal words and be alert to the potential for personal injury or property damage.

▲ DANGER

Warns of hazards that WILL cause serious personal injury, death or major property damage.

▲ WARNING

Warns of hazards that CAN cause serious personal injury, death or major property damage.

▲ CAUTION

Warns of hazards that CAN cause personal injury or property damage.

▲ NOTICE

INDICATES SPECIAL INSTRUCTIONS WHICH ARE VERY IMPORTANT AND MUST BE FOLLOWED.

THOROUGHLY REVIEW ALL INSTRUCTIONS AND WARNINGS PRIOR TO PERFORMING ANY WORK ON THIS PUMP.

MAINTAIN ALL SAFETY DECALS.

NOTE: Pumps with the "UL" mark and pumps with the "US" mark are tested to UL Standard UL778. CSA Certified pumps are certified to CSA Standard C22.2 No. 108.

REFER TO WARRANTY ON PAGE 2.

Limited Warranty

Manufacturer warrants, to the purchaser and subsequent owner during the warranty period, every new product to be free from defects in material and workmanship under normal use and service, when properly used and maintained, for a period of one year from date of purchase by the end user, or 18 months from date of original manufacture of the product, whichever comes first. Parts that fail within the warranty period, one year from date of purchase by the end user, or 18 months from the date of original manufacture of the product, whichever comes first, that inspections determine to be defective in material or workmanship, will be repaired, replaced or remanufactured at Manufacturer's option, provided however, that by so doing we will not be obligated to replace an entire assembly, the entire mechanism or the complete unit. No allowance will be made for shipping charges, damages, labor or other charges that may occur due to product failure, repair or replacement.

This warranty does not apply to and there shall be no warranty for any material or product that has been disassembled without prior approval of Manufacturer, subjected to misuse, misapplication, neglect, alteration, accident or act of nature; that has not been installed, operated or maintained in accordance with Manufacturer's installation instructions; that has been exposed to outside substances including but not limited to the following: sand, gravel, cement, mud, tar, hydrocarbons, hydrocarbon derivatives (oil, gasoline, solvents, etc.), or other abrasive or corrosive substances, wash towels or feminine sanitary products,

etc. in all pumping applications. The warranty set out in the paragraph above is in lieu of all other warranties expressed or implied; and we do not authorize any representative or other person to assume for us any other liability in connection with our products.

Contact Manufacturer at, 3649 Cane Run Road, Louisville, Kentucky 40211, Attention: Customer Service Department to obtain any needed repair or replacement of part(s) or additional information pertaining to our warranty.

MANUFACTURER EXPRESSLY DISCLAIMS LIABILITY FOR SPECIAL, CONSEQUENTIAL OR INCIDENTAL DAMAGES OR BREACH OF EXPRESSED OR IMPLIED WARRANTY; AND ANY IMPLIED WARRANTY OF FITNESS FOR A PARTICULAR PURPOSE AND OF MERCHANTABILITY SHALL BE LIMITED TO THE DURATION OF THE EXPRESSED WARRANTY.

Some states do not allow limitations on the duration of an implied warranty, so the above limitation may not apply to you. Some states do not allow the exclusion or limitation of incidental or consequential damages, so the above limitation or exclusion may not apply to you.

This warranty gives you specific legal rights and you may also have other rights which vary from state to state.

In instances where property damages are incurred as a result of an alleged product failure, the property owner must retain possession of the product for investigation purpose.

Service Checklist



▲ WARNING ELECTRICAL PRECAUTIONS- Before servicing a pump, always shut off the main power breaker and then unplug the pump - making sure you are not standing in water and wearing insulated protective sole shoes. Under flooded conditions, contact your local electric company or a qualified licensed electrician for disconnecting electrical service prior to pump removal.

▲ WARNING Submersible pumps contain oils which becomes pressurized and hot under operating conditions - allow 2-1/2 hours after disconnecting before attempting service.

CONDITION	COMMON CAUSES
A. Pump will not start or run.	Check fuse, low voltage, overload open, open or incorrect wiring, open switch, impeller or seal bound mechanically, defective capacitor or relay when used, motor or wiring shorted. Float assembly held down. Switch defective, damaged, or out of adjustment.
B. Motor overheats and trips overload or blows fuse.	Incorrect voltage, negative head (discharge open lower than normal) impeller or seal bound mechanically, defective capacitor or relay, motor shorted.
C. Pump starts and stops too often.	Float tight on rod, check valve stuck or none installed in long distance line, overload open, level switch(s) defective, sump pit too small.
D. Pump will not shut off.	Debris under float assembly, float or float rod bound by pit sides or other, switch defective, damaged or out of adjustment.
E. Pump operates but delivers little or no water.	Check strainer housing, discharge pipe, or if check valve is used vent hole must be clear. Discharge head exceeds pump capacity. Low or incorrect voltage. Incorrect motor rotation. Capacitor defective. Incoming water containing air or causing air to enter pumping chamber.
F. Drop in head and/or capacity after a period of use.	Increased pipe friction, clogged line or check valve. Abrasive material and adverse chemicals could possibly deteriorate impeller and pump housing. Check line. Remove base and inspect.

If the above checklist does not uncover the problem, consult the factory - Do not attempt to service or otherwise disassemble pump. Service must be by Zoeller Authorized Service Stations.

Preinstallation Information

1. Inspect your pump. Occasionally, products are damaged during shipment. If the unit is damaged, contact your dealer before using. DO NOT remove the test plugs in the cover nor the motor housing.
2. Carefully read the literature provided to familiarize yourself with specific details regarding installation and use. These materials should be retained for future reference.



⚠ WARNING

SEE BELOW FOR
LIST OF WARNINGS

1. Do not lift, carry, or hang pump by the electrical cables. Damage to the electrical cables can cause shock, burns or death.
2. Make sure there is a properly grounded receptacle available. All pumps are furnished with provisions for proper grounding to help protect you against the possibility of electrical shock.
3. Make certain that the receptacle is within the reach of the pump's power supply cord. DO NOT USE AN EXTENSION CORD. Extension cords that are too long or too light do not deliver sufficient voltage to the pump motor. But, more important, they could present a safety hazard if the insulation were to become damaged or the connection end were to fall into the sump.
4. Make sure the pump electrical supply circuit is equipped with fuses or circuit breakers of proper capacity. A separate branch circuit is recommended, sized according to the "National Electrical Code" for the current shown on the pump nameplate.
5. FOR ADDED SAFETY. Pumping and other electrical equipment must be connected to a 3-prong grounded receptacle with integral ground-fault circuit interrupter (GFCI).
6. Risk of electric shock - These pumps have not been investigated for use in swimming pool areas.
7. Prop65 warning for California residents: cancer and reproductive harm- www.P65Warnings.ca.gov.

⚠ CAUTION

SEE BELOW FOR
LIST OF CAUTIONS

1. Check to be sure your power source is capable of handling the voltage requirements of the motor, as indicated on the pump nameplate.
2. The installation of pumps using auxiliary variable level float switches is the responsibility of the installing party and care should be taken that the tethered float switch will not hang up on the pump apparatus or pit peculiarities and is secured so that the pump will shut off. It is recommended that rigid piping and fittings be used and the pit be 36" or larger in diameter.
3. INFORMATION - VENT HOLE PURPOSE. It is necessary that all submersible sump, effluent, and sewage pumps capable of handling various sizes of solid waste be of the bottom intake design to reduce clogging and seal failures. If a check valve is incorporated in the installation, a vent hole (approx. 3/16") must be drilled in the discharge pipe below the check valve and pit cover to purge the unit of trapped air. Trapped air is caused by agitation and/or a dry basin. This vent hole should be checked periodically for clogging and cleaned as necessary. Water stream will be visible from this hole during pump run periods.
4. Water hammer creates momentary high pressure surges. These surges can cause severe damage to check valves and the piping system. Consideration for water hammer must be included in the piping system design. Reference ASPE Data Book, Chapter 2.33. Some systems may require external spring or lever weighted check valves or other engineered solutions.

REFER TO WARRANTY ON PAGE 2.

Pump Performance Data

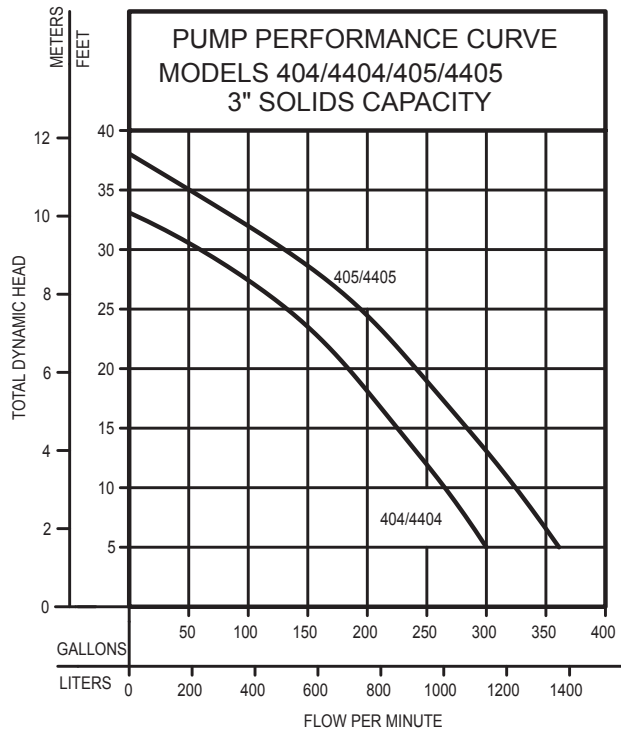

MODEL		404/4404		405/4405	
Feet	Meters	Gal.	Liters	Gal.	Liters
5	1.5	300	1136	361	1367
10	3.0	265	1003	326	1234
15	4.6	224	848	284	1075
20	6.1	184	698	241	912
25	7.6	134	503	197	746
30	9.1	60	227	134	507
35	10.7	--	--	50	189
Shut-off Head:		33 ft.(10.1m)		38 ft.(11.6m)	

012116

Electrical Data

Model	HP	RPM	Voltage	Ph	HZ	Amps Full Load (@ 5')	Amps Locked Rotor	KVA Code	Fuse/Circuit Breaker Amps (Delay)	Winding Resistance Line-to-Line
E404	2	1725	230	1	60	12.9	44.0	F	20	1.7
WD404	2	1725	230	1	60	12.9	44.0	F	20	1.7
I404	2	1725	200/208	1	60	14.4	49.5	E	20	1.2
J404	2	1725	200/208	3	60	13.8	46.0	J	20	1.5
F404	2	1725	230	3	60	10.5	42.0	K	15	2.2
G404	2	1725	460	3	60	5.2	21.0	K	10	8.8
BA404*	2	1725	575	3	60	4.1	17.9	K	10	13.6
E405	3	1725	230	1	60	19.0	44.0	C	25	1.7
WD405	3	1725	230	1	60	19.0	44.0	C	25	1.7
I405	3	1725	200/208	1	60	20.2	49.5	B	30	1.2
J405	3	1725	200/208	3	60	14.8	46.0	F	20	1.5
F405	3	1725	230	3	60	12.2	42.0	G	20	2.2
G405	3	1725	460	3	60	6.1	21.0	G	10	8.8
BA405*	3	1725	575	3	60	4.8	17.9	G	10	13.6

*Obsolete as of 1/2023

Typical Dewatering Installation

All installations must comply with all applicable electrical and plumbing codes, including, but not limited to, National Electrical Code, local, regional, and/or state plumbing codes, etc.

1. Electrical wiring and protection must be in accordance with the National Electrical Code, and any other applicable state and local electrical requirements.
2. Install proper full flow check valve, equal to Zoeller Pump Company P/N 30-0160 (3") or P/N 30-0170 (4") preferably just above the basin.
3. Install proper pump starting controls. Refer to Zoeller FM1596 or FM0486.
4. Install proper full flow shut off valve. One per pump.
5. All installations require a basin cover to prevent debris from falling into the basin and to prevent accidental injury.
6. To prevent air locking, drill a 3/16" diameter hole in the discharge pipe below the check valve even with the top of the pump. Note: The hole must be below the basin cover and cleaned periodically.
7. Secure power cord to avoid entanglement with variable level float switch mechanism.
8. Do not reduce pump discharge pipe below 3" IPS size.
9. Basin must be in accordance with all applicable codes and specifications.
10. Pump must be level and the tethered variable float switch must be free and not hang up on pump or pit peculiarities.
11. Install ring and chain for lifting pump from pit.
12. If rail system is used (not shown in sketch), discharge elbow must be firmly anchored to the bottom of basin. No part of the pump can rest on the floor. The cantilevered weight of the pump is required to seal the discharge connection. Refer to Zoeller FM0793 for rail system installation Instructions.
13. Basin must be clean and free of debris after installation.

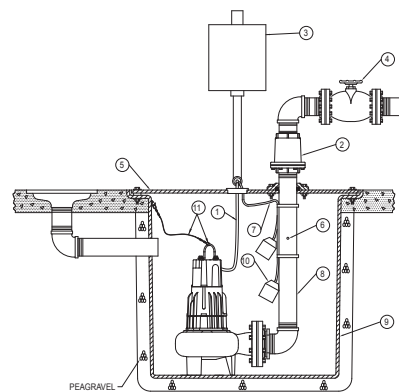

SK1026

Typical Sewage Installation

All installations must comply with all applicable electrical and plumbing codes, including, but not limited to, National Electrical Code, local, regional, and/or state plumbing codes, etc.

1. Electrical wiring and protection must be in accordance with the National Electrical Code, and any other applicable state and local electrical requirements.
2. All installations require a basin cover to prevent debris from falling into the basin and to prevent accidental injury.
3. Do not reduce pump discharge pipe below 3" IPS size.
4. Install proper full flow unichack valve, equal to Zoeller Pump Company P/N 30-0160 (3") or P/N 30-0170 (4").
5. When a check valve is installed, drill a 3/16" diameter hole in the discharge pipe below the check valve even with the top of the pump. Note: The hole must be below the basin cover and cleaned periodically.
6. Install proper full flow shut off valve. One per pump.
7. Secure power cord to avoid entanglement with variable level float switch mechanism.
8. Pump must be level and the tethered variable float switch must be free and not hang up on pump or pit peculiarities.
9. Install ring and chain for lifting pump from pit.
10. Vent gases and odors to the atmosphere through vent pipe per Local and State codes.
11. If rail system is used, discharge elbow must be firmly anchored to the bottom of basin. No part of the pump can rest on the floor. The cantilevered weight of the pump is required to seal the discharge connection. Refer to Zoeller FM0793 for rail system installation Instructions.
12. Basin must be clean and free of debris after installation.

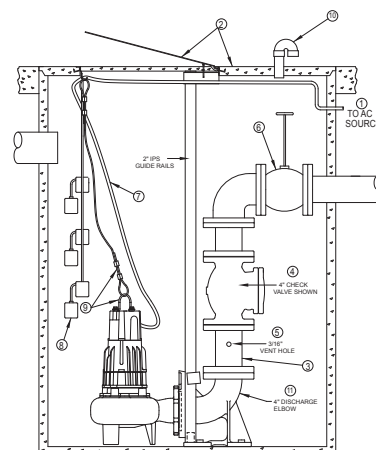

SK1025

Pump Wiring Instructions



▲ WARNING FOR YOUR PROTECTION, ALWAYS DISCONNECT PUMP FROM ITS POWER SOURCE BEFORE HANDLING. Single phase pumps are supplied with a 3-prong grounded plug to help protect you against the possibility of electrical shock. **DO NOT UNDER ANY CIRCUMSTANCES REMOVE THE GROUND PIN.** The 3-prong plug must be inserted into a mating 3-prong grounded receptacle. If the installation does not have such a receptacle, it must be changed to the proper type, wired and grounded in accordance with the National Electrical Code and all applicable local codes and ordinances.

All three phase pumps require motor starting devices with motor overload protection. See FM0514 for simplex installations or FM0486 for duplex installations. Three phase pumps must be installed in accordance with the National Electrical Code and all applicable local codes and ordinances. Pumps are not to be installed in locations classified as hazardous in accordance with National Electrical Code, ANSI/NFPA 70.



▲ WARNING "Risk of electrical shock" Do not remove power supply cord and strain relief or connect conduit directly to the pump.

▲ WARNING Installation and checking of electrical circuits and hardware should be performed by a qualified licensed electrician.

Single Phase Installation

Models E404/E405 and I404/I405 are nonautomatic. To operate automatically a control panel or 20 amp control switch (P/N 10-0748) must be added to the power circuit. Follow the instructions provided with the panel or float switch to wire the system.

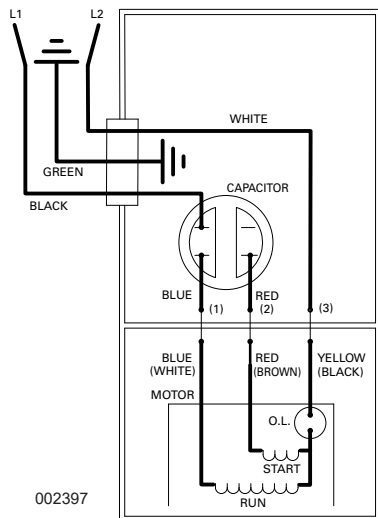

002397

WIRING DIAGRAM FOR MODELS
 E404/E405 - 230V, 1 PH, 60 HZ
 I404/I405 - 200/208V, 1 PH, 60 HZ
 E4404/E4405 - 230V, 1 PH, 60 HZ
 I4404/I4405 - 200/208V, 1 PH, 60 HZ

Three Phase Installation

Three phase pumps are nonautomatic. To operate automatically, a control panel is required. Follow the instructions provided with the panel to wire the system.

Before installing a pump, check the pump rotation to insure that wiring has been connected properly to power source, and that the green lead of power cord (See wiring diagram), is connected to a valid ground. Momentarily energize the pump, observing the directions of kick back due to starting torque. Rotation is correct if kick back is in the opposite direction of rotation arrow on the pump casing. If rotation is not correct, switching of any two power leads other than ground, should provide the proper rotation.

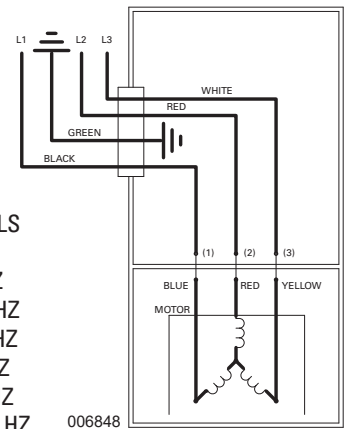

006848

WIRING DIAGRAM FOR MODELS
 F404/F405 - 230V, 3 PH, 60 HZ
 G404/G405 - 460V, 3 PH, 60 HZ
 J404/J405 - 200/208V, 3 PH, 60 HZ
 BA404/BA405 - 575V, 3 PH, 60 HZ
 F4404/F4405 - 230V, 3 PH, 60 HZ
 G4404/G4405 - 460V, 3 PH, 60 HZ
 J4404/J4405 - 200/208V, 3 PH, 60 HZ
 BA4404/BA4405 - 575V, 3 PH, 60 HZ

WD Model Installation

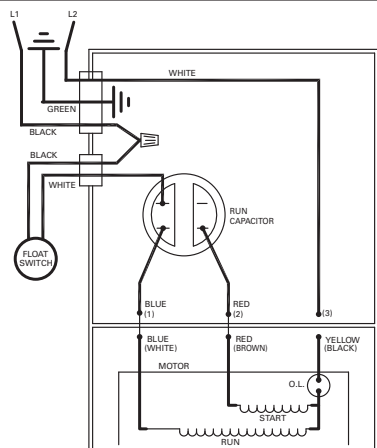

011835

WIRING DIAGRAM FOR MODELS
 WD405 - 230V, 1 PH, 60 HZ
 WH4405 - 200/208V, 1 PH, 60 HZ

Determining Pumping Range
 in Inches (1 inch - 2.5 cm)

Tether Length	5	10	15	20	22
	min.				max.
Pumping Range	9	13.5	18	22	24

Use only as a guide. Due to weight of cable, pumping range above horizontal is not equal to pumping range below horizontal. Ranges are based on testing in non-turbulent conditions. Range may vary due to water temperature and cord shape. As tether length increases, so does the variance of the pumping range.

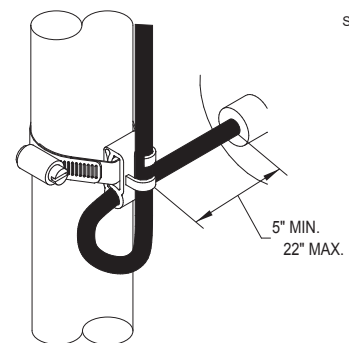

SK305D

20 AMP SWITCH (WD & WH MODELS)

Models WD404/WD405 are fully automatic. A float switch is included and factory wired in the pump circuit to provide automatic operation once the float switch is secured properly to the outlet pipe. Use the diagram above to secure the float switch properly and obtain the proper tether to customize the on-off cycle to each application.

Operation

GENERAL

Zoeller pumps are lubricated and tested at the factory prior to shipment and require minimum pre-start-up maintenance.

Maximum continuous operating temperature of pump liquid for standard model pumps must not exceed 130 °F (54 °C). WD models pump liquid should not exceed 120 °F (49 °C). Nonautomatic pumps and pumps with adjustable level controls must be totally submerged on long pumping cycles. A maximum of 1/2 hour run time per hour.

These units are not designed to handle liquids other than water or sewage. If pump is used in water contaminated with heavy, viscous, or abrasive materials, the warranty will be voided.

NAMEPLATE DATA

The nameplate, located on the top of pump, indicates specific information about the construction of the pump. The model number and date code information should be recorded on the front page in the "Owner's Information" section of this manual.

SHORT TERM STORAGE

If pump is to be stored for more than six months, the following is advised:

- Store pump inside whenever possible or cover with some type of protective covering.
- Tape or seal in plastic bag the terminal ends of wire leads.
- Spray coat unpainted surfaces with rust inhibiting oil.
- The impeller should be rotated every six months in order to keep the seals lubricated and not develop a permanent set.

If panel is to be stored for more than six months, the following is advised:

- Store the panel inside whenever possible and leave in the shipping box.
- All openings shall be sealed.
- Store in an upright position.
- Do not stack anything on top of panel.

STARTUP PROCEDURE

Before placing the equipment into operation the following checked:

- Correct pump rotation (3 Phase units only).
- Clean pit.
- Panel dry and securely installed.
- Floats positioned properly.
- Discharge valves open.
- 3/16" vent hole drilled in pipe between check valve and pump.

Once the above has been verified proceed with the following checks:

- Pump power cables properly connected to panel.
- Float cables properly connected to panel.
- Conduit connections to panel are properly sealed.
- Thermal overload adjustments made in the panel.
- After installing the pump into the containment area, with adequate submergence, open the discharge valve fully. Start the unit using manual controls. If flow is appreciably less than rated performance, pump may be air locked. To expel trapped air, jog the unit several times, using the manual controls.
- Have a qualified electrician take voltage and current measurements on the black wire of single phase or all three power wires of three phase with the pump running. Record these readings in the space provided in the "Owner's Information" section of this manual for future reference.

After the preoperational functional test has been completed, system is ready for operation. Zoeller recommends completing a Start-up Report (FM0990) whenever a system is started for the first time or after a system has had a significant change take place (i.e. pump replacement, overhaul, ect.). A copy of the Start-up Report should remain with the system for future reference.

ADJUSTMENT PROCEDURE

- Pumps: No adjustments are required other than assuring correct rotation.
- Panels: The thermal overloads in the panel (3 Ph systems) must be set to the F.L.A. rating on the pump nameplate (or refer to pump data sheet).
- Floats: Refer to the system drawing for desired location of each float function.
- Valves: Discharge valves should be placed in the fully open position. Systems should not be operated for extended periods of time with the discharge valves partially closed due to damaging the valve.

SHUTDOWN PROCEDURES

If a system is shutdown for more than six months, the following is recommended:

- Pumps: If pit is to remain dry, then the pump can remain in the pit. With the pump in the pit, it should be operated for five minutes once every three months. If the pit is to remain wet, the pump should be removed and stored as noted below.
- Panels: The panel should have all openings sealed to prevent moisture and dust from entering the enclosure. Prior to restarting system, the panel should be inspected for presence of moisture and any loose connections.
- Valves: Consult the valve/actuator supplier for information concerning these systems components (used on dewatering pump stations only).

Maintenance

▲ NOTICE Repair and service should be performed by a Zoeller Pump Company Authorized Service Station only.

SAFETY PROCEDURES

▲ WARNING For your protection, always disconnect pump and panel from its power source before handling.

▲ WARNING Never enter the basin until it has been properly vented and tested. Any person entering a basin should be wearing a harness with safety rope extending to the surface so that they can be pulled out in case of asphyxiation. Sewage water gives off methane and hydrogen sulfide gases, both of which can be highly poisonous.

Installation and checking of electrical circuits and hardware should be performed by a qualified electrician.

Pump is never to be lifted by power cord.

▲ WARNING Unit must be flushed and disinfected, inside and out, prior to servicing.

GENERAL SYSTEM INSPECTION

Before the system is placed into operation, a system Start-up Report should be conducted by a qualified technician.

▲ WARNING Wiring and grounding must be in accordance with the national electrical code and all applicable local codes and ordinances.

LUBRICATION PROCEDURES

No lubrication is required.

If pumps are to be stored for more than six months, refer to short term storage procedure in the Operation section.

PREVENTIVE MAINTENANCE

Preventive maintenance is recommended to ensure a long service life from the product. Provided is a suggested maintenance schedule.

Every month:

- Check for proper and unobstructed float operation.
- Listen for proper check valve operation.
- Activate pumps and take voltage and amperage readings.

Maintenance (continued)

- Visually inspect system and replace defective components and remove debris or mud in the basin.
- Inspect the panel for any presence of moisture in enclosure, loose connections, and general component condition.
- Check out location and condition of float switches.

Every 5 years or 10,000 hours of operation:

- Remove pump. Inspect and service using a Zoeller Rebuild Kit.
- Flush and clean basin.
- Inspect power cables for damage or wear. Replace immediately if damage or wear is detected.
- Inspect impeller for damage or wear.

DOUBLE SEAL PUMPS

- Double seal pumps offer extra protection from damage caused by seal failure.
- Oil in a motor housing and lower seal cavity must be changed when pump is serviced. If oil from the motor housing contains water or other contamination, both seals should be replaced during maintenance. Always replace with new factory recommended oil and service parts. All repairs must be made by Zoeller Authorized Service Stations.

Replacement Parts

The following parts lists are provided for ordering service parts. Consult factory for specific part numbers. Please have pump model number and date code for immediate service. All repair and service should be preformed by a Zoeller Pump Company authorized service station.

REF. NO.	DESCRIPTION	*QTY	NOTES
1	Cover & Cord Asm	1	3
2	Bolt, Eye	1	
3	Cover-Mach.	1	3
4	• Gasket, Case/Cover	1	
5	Relay 200-230V, 1 Ph	0 to 1	
6	• Wire Pkg (5) Wires	0 to 1	
7	Capacitor & Clamp Asm.	0 to 1	
8	Housing, Mtr-Str	1	1 & 2
9	Bearing, Sleeve	1	
10	• Plug, T est White	2 to 3	
11	• Seal, Thru Wall Term	3	
12	Rotor & Brg	1	2
13	• Bearing, Radial	1	
14	• Seal, Mtr Hsg	1 to 2	
15	• Oil, Dielectric-(44 Oz.Can)	1	
16	Adapter-Mach.	1	
17	• Washer, Seal Locating & Snap Ring	0 to 1	
18	• Seal, Shaft	1 to 2	
19	Adapter-Mach. Lower	0 to 1	
20	Impeller Asm	1	
21	Key, Woodruff #404	1	
22	Washer, 7/16 Std Flat SS	1	
23	Nut, 7/16-20 SS Hex	1	

REF. NO.	DESCRIPTION	*QTY	NOTES
24	Housing, Pump-Mach.	1	
25	Cord Term & Seal Power	1	3
26	• Seal, Cord-Asm & Str Rlf	1	3
27	Seal, Cord-Asm & STRRLF	0 to 1	
28	Clamp, #6 Auto-SS	0 to 1	
29	Cord Term & Seal Control	0 to 1	
30	• Seal, Cord-Asm & Str Rlf Control Cord	0 to 1	
31	Clamp Str Rlf	0 to 1	
32	• Screw, #6-32 x .25 RHM SI Tc Stlgr	1 to 4	
33	Float Switch Term & Seal	0 to 1	
34	• Seal, Float Switch Cord-Asm & Strain Relief	0 to 1	
35	Connector, Wirenut	0 to 1	
36	• Screw, .25-20 x .75 HHm-SS	4	
37	• Screw, .25-20 x 1" HHm-SS	4	
38	• Screw, .313-18 x 1 HH Cap-SS	4 to 8	
39	• Screw, .313-18 x 1 HH Cap-SS	2	
40	• Washer, Flat - SS	2	
41	Bracket, Lifting - SS	1	
42	Resistor, Moisture Sensor Asm.	0	
43	Wire Asm. Sensor	0	
44	Cord Term & Seal Sensor	0	
45	Seal, Cord-Asm & Strain Relief Sensor	0	
46	• Washer, Lock - SS	2	
	Rebuild Kit	1	

*Indicates items included in rebuild kit. *Quantities vary depending upon model, voltage, and phase.

NOTES:

- 1) Mtr. Hsg., Brg., Stator & Term. (Item 8) are preassembled at the factory and must be replaced as a unit. Stator is permanently attached to Mtr. Hsg. Plug (Item 10); Seal, Thru Wall Term. (Item 11) and Bearing (Item 9) are replaceable.
- 2) When ordering Motor Housing, Bearing, Stator, and Term (Item 8); or Rotor and Bearing (Item 12) specify either GE or Emerson motor.
- 3) If an "X" follows Model No., or Date Mfg. on brass I.D. tag, consult factory for ordering of this part.
- 4) See FM1641 (404/4404) and FM0948 (405/4405) replacement parts list for listing of part numbers.
- 5) See FM0160 Parts Price Sheet for listing of parts prices.

Replacement Parts (continued)

APPLICABLE CORD, SEAL, & GROUND SCREW

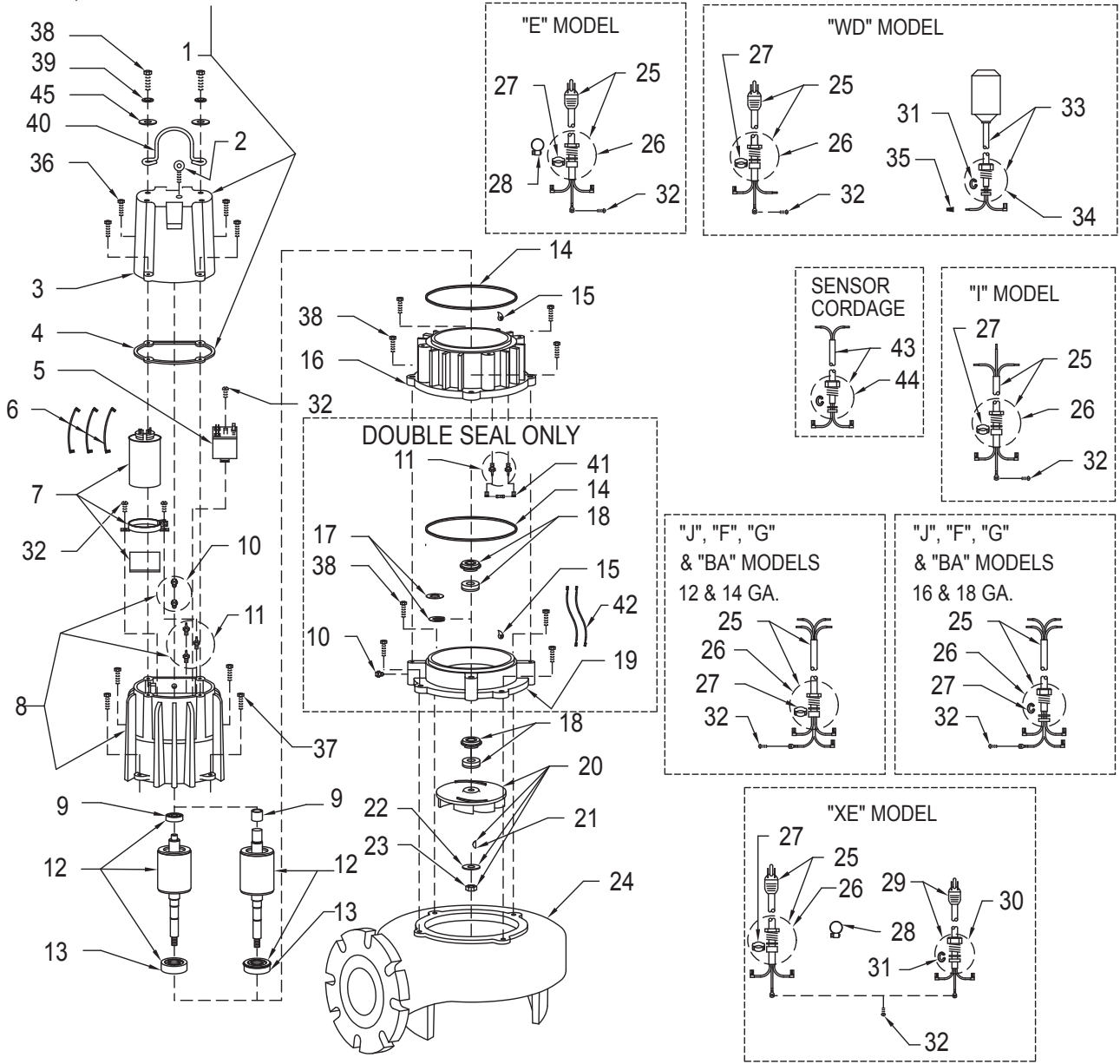

SK1814