

Before You Begin...

- This guide provides an overview of basic Pivot features - further explanation can be found in the manual
- Pivot uses intelligent logic to keep the system operational in the event of failures – certain behaviors may be unfamiliar at first
- Pivot is designed to use just 3 floats for most applications, regardless of simplex and duplex configurations

Essential Electrical Connections

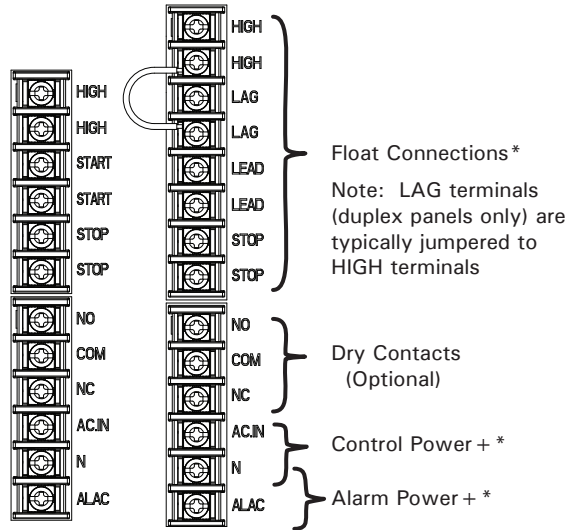

Simplex **Duplex**

+ Note: Both Control and Alarm terminals require power for proper operation

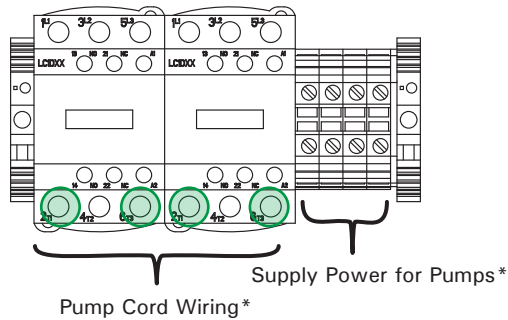

Basic Functions

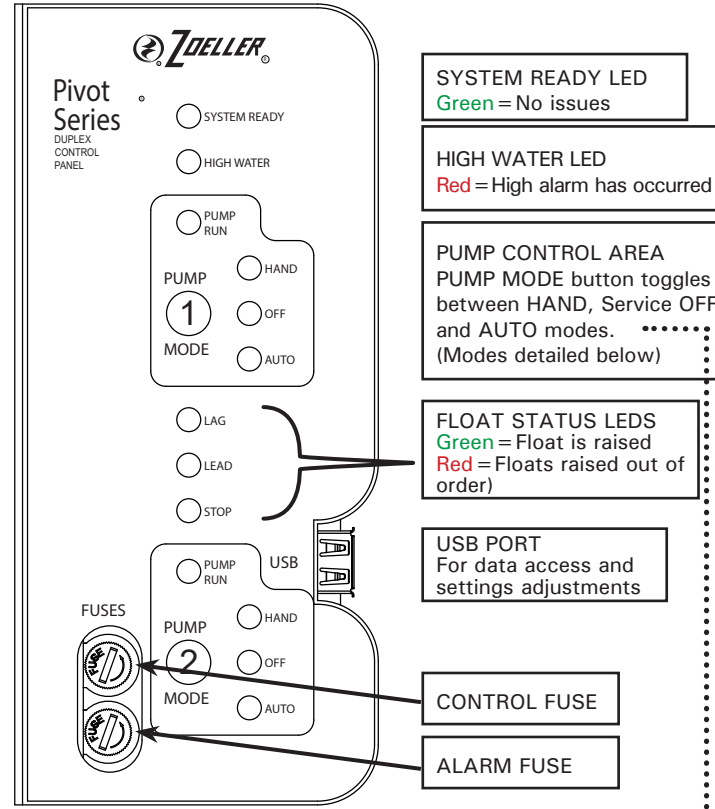

- SYSTEM READY LED**
Green = No issues
- HIGH WATER LED**
Red = High alarm has occurred
- PUMP CONTROL AREA**
PUMP MODE button toggles between HAND, Service OFF, and AUTO modes. (Modes detailed below)
- FLOAT STATUS LEDS**
Green = Float is raised
Red = Floats raised out of order
- USB PORT**
For data access and settings adjustments
- CONTROL FUSE**
- ALARM FUSE**

- HAND Mode (Solid Blue LED)**
-Pump will start and run regardless of float status.
-After 5 minutes in HAND Mode, pump will switch to AUTO Mode
- Service OFF Mode (Solid Red LED)**
-Pump will not operate regardless of float status
-After 4 hours in Service OFF Mode, an alarm will sound
- Permanent OFF Mode (Blinking Red LED)**
-Deactivates pump, without alarm, until Mode button is pressed again
-Hold PUMP MODE button for 5 seconds to enter Permanent OFF Mode
- AUTO Mode**
-Pump will operate automatically based on float status

Startup Process

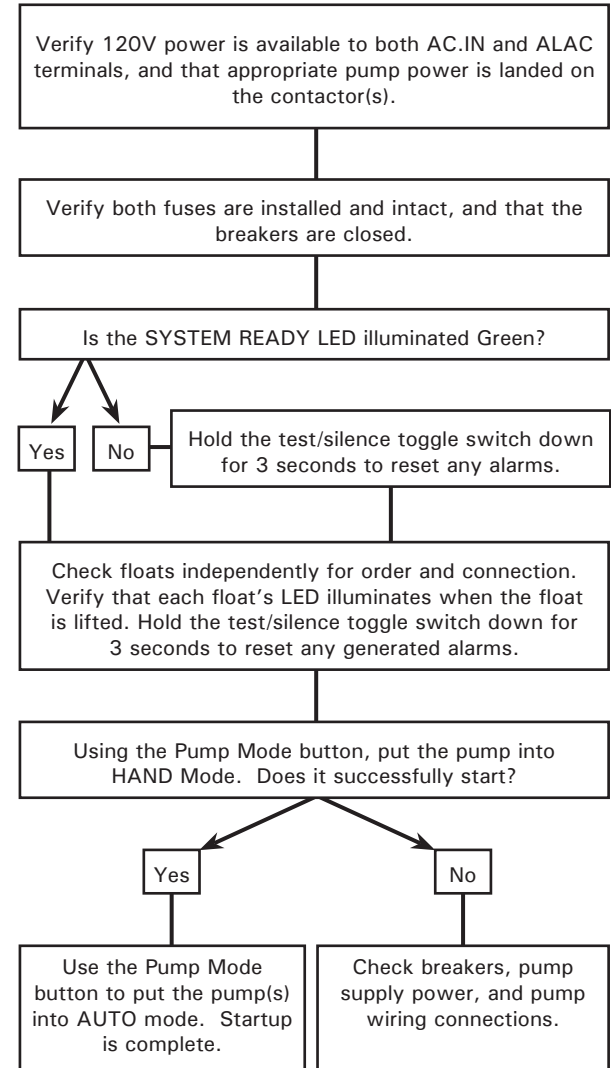

* Denotes required connections