

Trusted. Tested. Tough.™

Product information presented here reflects conditions at time of publication. Consult factory regarding discrepancies or inconsistencies.



SECTION: 2.45.030

FM2605

1216

Supersedes

0215

MAILTO: P.O. BOX 16347 • Louisville, KY 40256-0347
SHIP TO: 3649 Cane Run Road • Louisville, KY 40211-1961
TEL: (502) 778-2731 • 1 (800) 928-PUMP • FAX: (502) 774-3624

Visit our web site:
zoellerpumps.com



QWIK PAK LS Universal Lift Station



This document is designed to provide a means to configure a simplex or duplex pump system that is suitable for stocking. The systems are configured in a manner that enables them to be used with a variety of pump models. Contact the factory for a lead time for other basin sizes, pump models and accessory combinations.

Basin Sizes include:

Simplex

- 24" X 60"
- 24" X 84"

Duplex

- 36" X 60"
- 36" X 84"

The Lift Station includes:

- Fiberglass Basin with AFD
- Z-Rail® Disconnect System
- SS Lifting Bracket & Lifting Cable
- 2" Flange adapter for 160 / 180 Series
- 2" PVC Ball Valve
- 2" Cast Iron Check Valve
- 4" Pipe Seal Inlet Hub
- Outdoor rated Solid Fiberglass Cover
- (3) 15' Float switches with float tree



SEWAGE AND EFFLUENT LIFT STATION COMPONENTS

SIMPLEX SYSTEM - ONE PUMP				DUPLEX SYSTEM - TWO PUMPS			
(A) Pump Model (1 ea.)	(1)	-		(A) Pump Model (2 ea.)	(2)	-	
(B) Simplex Control Panel	(1)	10-		(B) Duplex Control Panel	(1)	10-	
(C) Rail Slide Assembly Kit	(1)	10-		(C) Rail Slide Assembly Kit (2 ea.)	(2)	10-	
(D) Simplex Basin Assembly	(1)	35-		(D) Duplex Basin Assembly	(1)	35-	
(E) Accessories*				(E) Accessories*			
	Vent	(1)	10-		Vent	(1)	10-
	Extension	(1)	31-		Extension	(1)	31-
	Junction Box	(1)	10-		Junction Box	(1)	10-

*All accessories are *optional* and **MUST** be field installed.

A - PUMP SELECTION

Sump/Effluent - 2" Discharge, 3/4" Solids Capacity

- 161 1/2 HP, N161-15.0 A / E161-7.5A / I161-8.8A
- 163 1/2 HP, N163-15.0 A / E163-7.5A / I163-8.5A
- 165 1 HP, E165-10.2A / I165-12.6A
- 185 1 HP, E185-9.8A / I185-11.5A
- 186 1-1/2 HP, E186-13.7A / I186-17.2A
- 188 1-1/2 HP, E188-14.0A / I188-16.8A
- 189 2 HP, E189-17.1A / I189-20.5A
- 191 2 HP, E191-14.5A, 5/8" solids

Sewage - 2" Discharge, 2" Solids Capacity

- 282 1/2 HP, N282-10.3A / E282-5.0A / I282-6.1A
- 284 1 HP, E284-8.9A / I284-9.3A
- 292 1/2 HP, N292-15.0A / E292-7.5A / I292-8.8A
- 293 1 HP, E293-10.2A / I293-12.0A
- 294 1-1/2 HP, E294-13.7A / I294-17.8A
- 295 2 HP, E295-17.1A / I295-20.5A

Sewage Grinder - 1-1/4" Discharge

- 820 2 HP, E820-13.7A / I820-15.5A

For additional pump configurations, consult factory.

† Pumps have 1-1/2" discharge, 2" adapter flange provided with 10-3664 Rail Assembly Kit in Section C.

Voltage Requirements

- 115 V Single Phase - N*
 - 208 V Single Phase - I*
 - 230 V Single Phase - E*
- *Use letter as prefix for pump model,
N-161 = 115V single phase



Typical Pump

SK1023

B - PANEL SELECTION

Simplex single phase panel selections

- 10-1036 0-7 amps
- 10-1037 7-15 amps
- 10-1038 15-20 amps
- 10-1201 20-30 amps (I189 only)

Duplex single phase panel selections

- 10-1043 0-7 amps
- 10-1044 7-15 amps
- 10-1045 15-20 amps
- 10-1046 20-30 amps (I189 only)

Note: For 3-phase systems contact your sales representative.

SINGLE PHASE CONTROL PANEL FEATURES

- 115-208-230 Volts
- Dead front panel
- Equipment disconnect
- Motor contactor
- NEMA 4X watertight enclosure with lockable latch
- Top mounted alarm light
- Alarm horn provides audio warning of alarm condition (83 to 85 decibel rating)

Simplex

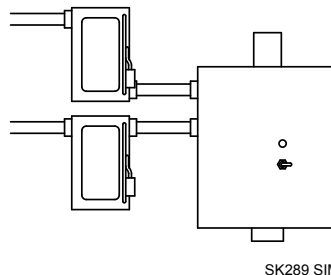

Duplex

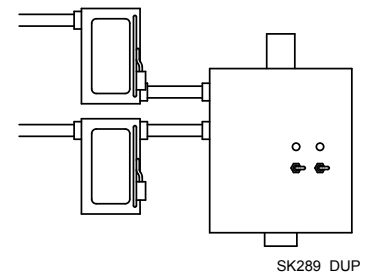

For additional control panel selections, consult selection guide FM1228 for Simplex and FM0712 for Duplex pump controls. (available on our website - www.zoellerpumps.com)

- Pump run indicator light
- Horn silence and alarm test toggle switches
- HOA switch
- Complete installation instructions included
- UL Listed for US & Canada
- Dry auxiliary contact

C - RAIL SLIDE ASSEMBLY KIT

- 10-3663 Rail Assembly Kit - 1-1/4" Pump Connection
- 10-3664 Rail Assembly Kit - 2" Pump Connection

The Rail Slide Assembly Kit includes all the necessary items to mount the pump onto the installed rail system of the prepackage basin rail system. One kit is required for simplex and two kits are required for duplex. The kit includes 1 each of the following items:

- Rail Slide with Plate, Guide and Mounting Elbow for a 1-1/4" or 2" Pump
 - 8' Stainless Steel Lifting Cable
 - Stainless Steel Lifting Bail
 - 2" Cast Iron NPT Threaded Discharge Flange (10-3664 only)
- Allows 1-1/2" discharge effluent pumps listed in Section A to be mounted on 2" rail system.*



D - FIBERGLASS BASIN ASSEMBLY

- 35-0068 24" x 60" Simplex Fiberglass Basin
- 35-0069 24" x 84" Simplex Fiberglass Basin
- 35-0070 36" x 60" Duplex Fiberglass Basin
- 35-0071 36" x 84" Duplex Fiberglass Basin

The Fiberglass Basin Assembly includes the following items:

- Fiberglass Basin
- Fiberglass Anti-Flotation Ring
- Fiberglass Cover
- 10' Stack Test steel cover available - Consult Factory*
- Z-Rail® Disconnect System with 2" Discharge
- Ductile Iron Construction
- Plate, Guide, and Mounting Elbow are included in the Rail Slide Assembly Kit (Section C).*
- 3/4" Galvanized Slide Rail Pipe
- 2" PVC Sch 40 Discharge Pipe
- 2" Cast Iron Check Valve (30-0152)
- 2" PVC Ball Valve w/ Extension Handle
- 4" Pipe Seal Inlet Hub
- PVC Float Tree & 3 -15' Float Switches (mechanical - non mercury)

The Fiberglass Basin Assembly 'D' **AND** Rail Slide Assembly Kit 'C' **MUST** be purchased together to provide a complete system. The Rail Slide Assembly Kit contains the necessary components to complete the disconnect rail system inside the basin. One kit is required for **EACH PUMP**.



E - ACCESSORIES

Junction Box*

All junction boxes are terminated for (3) Float Cords and (1) Pump Cord for Simplex and (2) Pump Cords for Duplex.

- Simplex J-Box: 10-0647 NEMA 4X
- Duplex J-Box: 10-0648 NEMA 4X

*Junction Box is **optional** - Check local requirements for use and location.

J-Box is shipped for field installation.

Junction Box

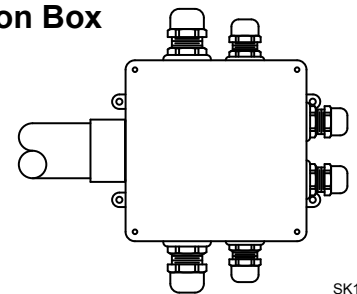

Fiberglass Basin Extension

- 31-0994 12" FG Extension for 24" Basin
- 31-0813 12" FG Extension for 36" Basin

Note: Use of more than one extension is not recommended!

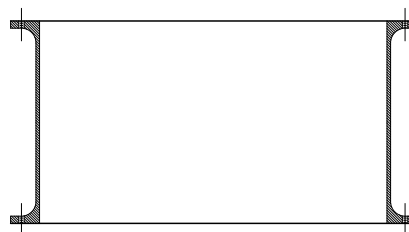

Extension



Vent & Flange

QWIK PAK LS: Preassembled Lift Station

SIMPLEX SYSTEM - ONE PUMP				DUPLEX SYSTEM - TWO PUMPS			
(A) Pump Model (1 ea.)	(1)	-	_____	(A) Pump Model (2 ea.)	(2)	-	_____
(B) Simplex Control Panel	(1)	10-	_____	(B) Duplex Control Panel	(1)	10-	_____
(C) Rail Assembly Kit	(1)	10-	_____	(C) Rail Assembly Kit (2 ea.)	(2)	10-	_____
(D) Simplex Basin Assembly	(1)	35-	_____	(D) Duplex Basin Assembly	(1)	35-	_____
(E) Accessories*	Vent	(1)	10-	(E) Accessories*	Vent	(1)	10-
	Extension	(1)	31-		Extension	(1)	31-
	Junction Box	(1)	10-		Junction Box	(1)	10-

*All accessories are *optional* and **MUST** be field installed.

SOLID FG COVER

DUPLEX

SIMPLEX

OPTIONAL
2" VENT
(FIELD-
INSTALLED)

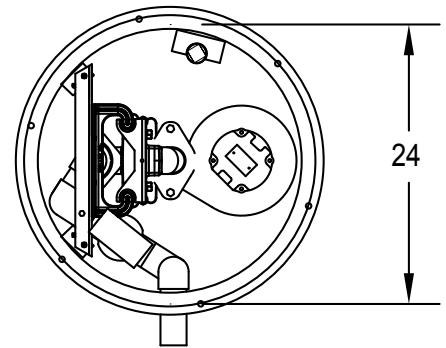
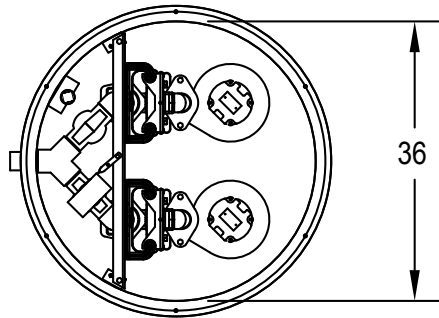
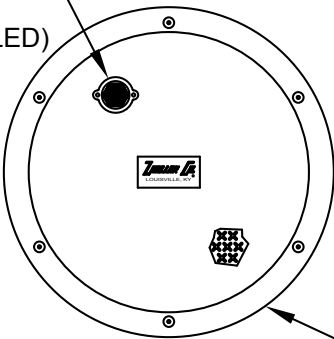

SOLID FIBERGLASS COVER

REMOVABLE FLOAT TREE

BALL VALVE
EXTENSION HANDLE

2" PVC BALL VALVE

36

4" PIPE SEAL
(FIELD INSTALLED)

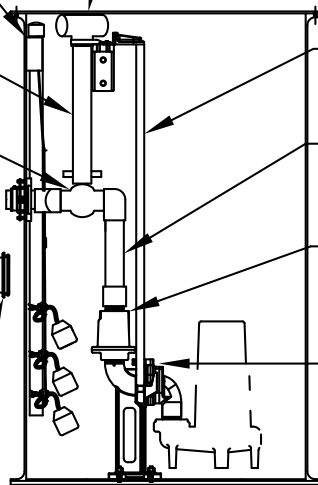

GUIDE RAIL PIPE
(GALVANIZED)

2" PVC PLUMBING
(SCH 40)

2" CAST IRON
CHECK VALVE

Z-RAIL

□ 60
□ 84

SK3023