

Trusted. Tested. Tough.®



SECTION: C1.20.130
CL0020
0421
Supersedes
0615

Product information presented here reflects conditions at time of publication. Consult factory regarding discrepancies or inconsistencies.

MAIL TO: P.O. BOX 16347 • Louisville, KY 40256-0347
SHIP TO: 3649 Cane Run Road • Louisville, KY 40211-1961
Tel: (502) 778-2731 • 1 (800) 928-PUMP

Visit our website:
zoellerpumps.com

Register your
Zoeller Pump Company Product
on our website:
<http://reg.zoellerpumps.com/>

Turbine STEP Systems OWNER'S MANUAL

Congratulations on the purchase of the Zoeller Pump Turbine STEP System. This system will provide years of trouble-free service when installed according to the manufacturer recommendations. This manual incorporates the installation, operation, maintenance, and service instructions into one document to aid in the ownership of a Zoeller Pump Company onsite wastewater product. Please read and review this manual before installing the product. Many items contained within, when followed correctly, will not only ensure a long and problem-free life for the system, but also save time and money during installation. Should further assistance be necessary please call Zoeller Pump Company at 1-800-928-7867.

GENERAL

The Turbine STEP System is designed to be an easily installed drop-in pump vault that does not require an additional pump chamber. However, it can be installed in a secondary pumping chamber. By utilizing a turbine effluent pump, high head pressures are achieved. Designed for convenience, the filters, as well as the float tree, are easily removed for servicing. The filter has 924 linear feet of 1/16" filtration. This large surface area ensures adequate filtering and a longer interval between servicing.

Table of Contents

Safety Instructions.....	1
Limited Warranty.....	2
General Instructions.....	2,4
Typical Filtered STEP System.....	3
Discharge Pipe & Pump Installation.....	4
Floats and Float Tree Installation.....	4-6
System Wiring Instructions.....	7
Junction Box Wiring.....	8
Startup.....	8
Operation.....	9
Maintenance.....	9
Replacement Parts.....	10
Engineered Systems.....	11

Safety Instructions

TO AVOID SERIOUS OR FATAL PERSONAL INJURY OR MAJOR PROPERTY DAMAGE, READ AND FOLLOW ALL SAFETY INSTRUCTIONS IN MANUAL AND ON PUMP.

THIS MANUAL IS INTENDED TO ASSIST IN THE INSTALLATION AND OPERATION OF THIS UNIT AND MUST BE KEPT WITH THE PUMP.



This is a **SAFETY ALERT SYMBOL**.

When you see this symbol on the pump or in the manual, look for one of the following signal words and be alert to the potential for personal injury or property damage.

▲ DANGER

Warns of hazards that **WILL** cause serious personal injury, death or major property damage.

▲ WARNING

Warns of hazards that **CAN** cause serious personal injury, death or major property damage.

▲ CAUTION

Warns of hazards that **CAN** cause personal injury or property damage.

▲ NOTICE

Indicates special instructions which are very important and must be followed.

THOROUGHLY REVIEW ALL INSTRUCTIONS AND WARNINGS PRIOR TO PERFORMING ANY WORK ON THIS SYSTEM. MAINTAIN ALL SAFETY DECALS.

Prop65 Warning for California residents: Cancer and reproductive harm-
www.P65warnings.ca.gov.

REFER TO WARRANTY ON PAGE 2.

Owner's Information

Model Number: _____ Date Code: _____

Job Name: _____

Dealer: _____

Date of Purchase: _____

Contractor: _____

Date of Installation: _____

System Readings During Operation: Voltage _____ Amps _____

Limited Warranty

Manufacturer warrants, to the purchaser and subsequent owner during the warranty period, every new product to be free from defects in material and workmanship under normal use and service, when properly used and maintained, for a period of one year from date of purchase by the end user, or 18 months from date of original manufacture of the product, whichever comes first. Parts that fail within the warranty period, one year from date of purchase by the end user, or 18 months from the date of original manufacture of the product, whichever comes first, that inspections determine to be defective in material or workmanship, will be repaired, replaced or remanufactured at manufacturer's option, provided however, that by so doing we will not be obligated to replace an entire assembly, the entire mechanism or the complete unit. No allowance will be made for shipping charges, damages, labor or other charges that may occur due to product failure, repair or replacement.

This warranty does not apply to and there shall be no warranty for any material or product that has been disassembled without prior approval of manufacturer, subjected to misuse, misapplication, neglect, alteration, accident or act of God; that has not been installed, operated or maintained in accordance with manufacturer's installation instructions; that has been exposed to outside substances including but not limited to the following: sand, gravel, cement, mud, tar, hydrocarbons, hydrocarbon derivatives (oil, gasoline, solvents, etc.), or other abrasive or corrosive substances, wash towels or feminine sanitary products, etc. in all pumping applications. The warranty set out in the paragraph above is in lieu of all other warranties expressed

or implied; and we do not authorize any representative or other person to assume for us any other liability in connection with our products.

Contact manufacturer at, 3649 Cane Run Road, Louisville, Kentucky 40211, Attention: Customer Support Department to obtain any needed repair or replacement of part(s) or additional information pertaining to our warranty.

MANUFACTURER EXPRESSLY DISCLAIMS LIABILITY FOR SPECIAL, CONSEQUENTIAL OR INCIDENTAL DAMAGES OR BREACH OF EXPRESSED OR IMPLIED WARRANTY; AND ANY IMPLIED WARRANTY OF FITNESS FOR A PARTICULAR PURPOSE AND OF MERCHANTABILITY SHALL BE LIMITED TO THE DURATION OF THE EXPRESSED WARRANTY.

Some states do not allow limitations on the duration of an implied warranty, so the above limitation may not apply to you. Some states do not allow the exclusion or limitation of incidental or consequential damages, so the above limitation or exclusion may not apply to you.

This warranty gives you specific legal rights and you may also have other rights which vary from state to state.

In instances where property damages are incurred as a result of an alleged product failure, the property owner must retain possession of the product for investigation purpose.

General Instructions

1. Installation must comply with all applicable electric codes, plumbing codes and health department regulations, including, but not limited to, the National Electrical Code, local, regional and/or state plumbing codes, etc.
2. If the Zoeller Pump Company Turbine STEP System is being retrofitted into an existing septic system, it will be necessary to pump and clean out the septic tank prior to installing. Before pumping, measure down from the top of the septic tank to the liquid level (not the scum layer) and record in the chart (see page 4). The top of the septic tank will become the reference plane for measuring to correctly install your system.
3. The inlet pipe is typically 3" above the outlet pipe. On a conventional gravity system, once the system is pumped and cleaned, check the dimensions from the top of the septic tank to the bottom of the inlet and outlet pipes. Record in the chart (see page 4). Each system varies! Therefore, don't assume a 3" difference between the inlet and outlet.
4. An 18" hole is required in the top of the septic tank to install the STEP system. If the hole in your septic tank is less than 18", provision must be made to enlarge the hole to 18" (you may have to change the lid of the septic tank).
5. If your system is not equipped with a riser, install a new Zoeller Pump Company 24" or 30" diameter riser on the outlet end of the septic tank. Follow the installation instructions provided with the riser.
6. Unpack the STEP system from the carton. Remove everything from the pump vault: filter pack, float tree, discharge assembly and instructions/hardware pack.
7. If necessary, cut a single inlet hole in the tank inlet tube (see page 11).
8. Install the two 16" long 1" schedule 80 PVC hanger pipes through the rim holes in the pump vault and lower the pump system through the riser and into the septic tank opening (see Fig. 1). In most cases, the pump vault will be suspended in the septic tank by the pipe hangers. If the septic tank is shallow, the pump vault may rest on the tank floor. The system is designed to operate properly in either case.
9. Install the piping from the lateral field to the outside of the riser on the septic tank.
10. If supplied or required, attach the check valve to the pump outlet. Disconnect the Zoeller pump company flexible pipe discharge assembly at the union on the ball valve. Connect the long part of the discharge assembly to the pump outlet or check valve with the pump set up outside the pump vault. If check valve is used, weep hole should be below check valve.
11. Tie off the power cord by strapping it to the upper end of the discharge pipe. Make certain the cord cannot become entangled or obstruct the movement of the floats. Lower the pump by the discharge pipe into the right or left pump well of the pump vault (see Fig. 1).
12. Reconnect the union loosely to see approximately where to install the pipe seal through the riser wall. Remove the pump by the discharge assembly. Drill the appropriate hole through the riser wall (see Fig. 2). Install the pipe seal through the riser wall to prevent ground water intrusion. Disconnect the union on the discharge assembly and install the flexible pipe through the pipe seal with the union ball valve on the inside of the riser (see Fig. 3). Solvent weld the flexible pipe to the lateral field piping using PVC pipe cement.
13. Lower the pump by the discharge assembly back into the appropriate pump well in the pump vault. Adjust the piping using the threaded elbows and flexible piping of the discharge assembly to achieve proper fit. Securely connect the union on the ball valve. Repeat steps 9-12 for a second pump in a dual pump system.
14. Measure and mark all float locations on the float tree. Install the cord holders on the float tree. Place one at each marked location rotating them approximately 90° apart in two quadrants (see Fig. 10).
15. Unpack variable level float switches from system. Remove and discard any float holders/clamps attached to float switch cords. Cut any piggyback plugs from any float switches. Measure 3-1/2" from the float switch on the cord and mark this spot. Using the appropriate float diagram section (see Figs. 6, 7, 8 & 9), assemble each float cord through the float holder and hand tighten (see Fig. 11).

Continued on page 4.

▲ WARNING Do not lower the pump by the power cord.

Typical Zoeller Pump Company Turbine STEP System

Zoeller Pump Company Turbine STEP Systems are designed for installation in septic tanks. The system should be installed through the riser on the discharge end of the septic tank. A complete system should include: 1) Filter and pump vault, 2) Filter cartridges, 3) Float tree/ switch assembly, 4) Effluent rated turbine pump, 5) Discharge pipe assembly, 6) Control/alarm system, 7) Junction box, 8) Prewired conduit, 9) Riser and lid.

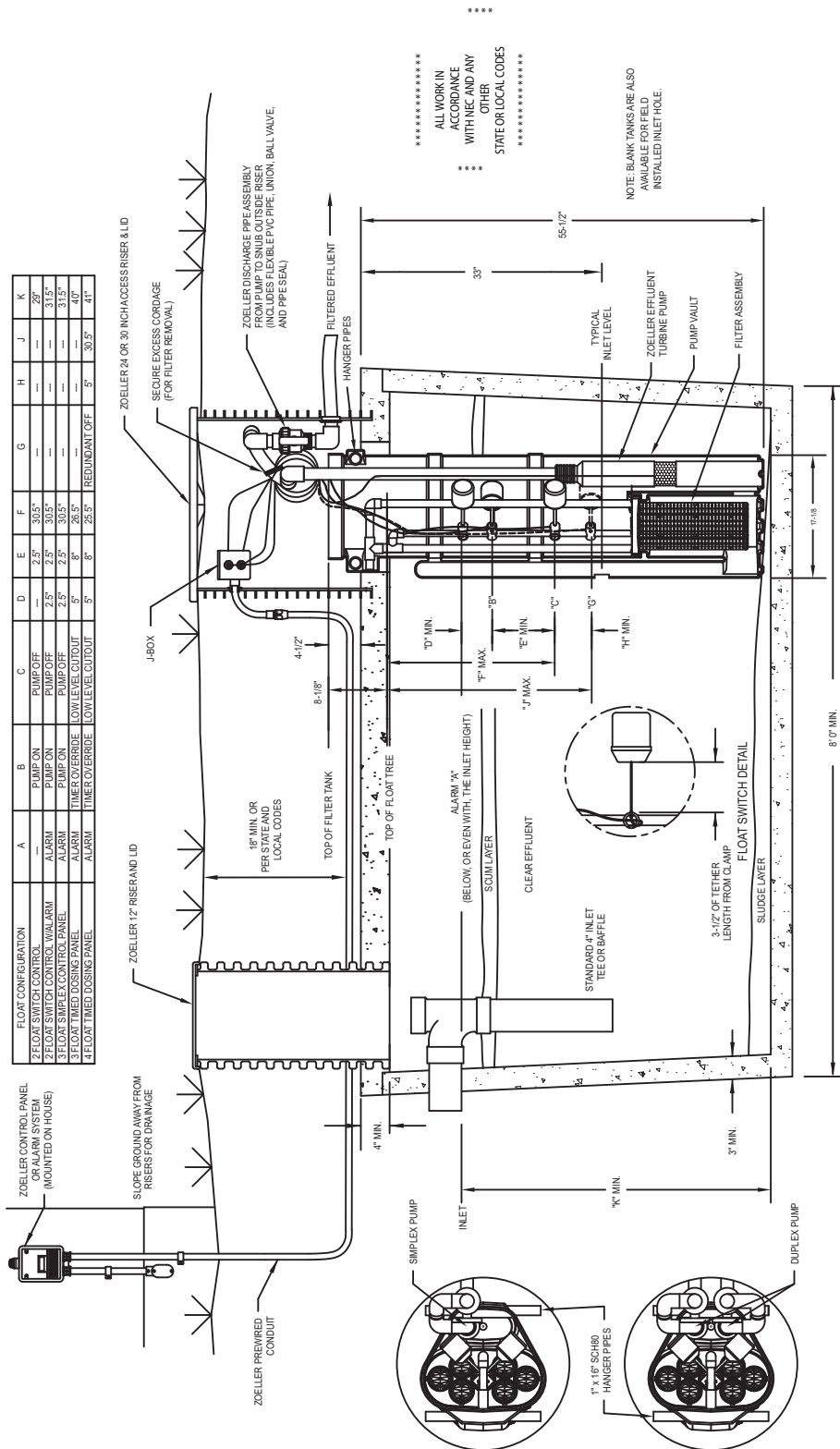

FLAT CONFIGURATION	A	B	C	D	E	F	G	H	J	K
1) FLOAT CONTROL PANEL	ALARM	PUMP ON	PUMP OFF	2.5"	2.5"	30.5"	---	---	---	30.5"
2) FLOAT SWITCH CONTROL PANEL	ALARM	PUMP ON	PUMP OFF	2.5"	2.5"	30.5"	---	---	---	31.5"
3) FLOAT SIMPLEX CONTROL PANEL	ALARM	TIMER OVERRIDE	LOW LEVEL CUTOUT	5"	8"	26.5"	---	---	---	40"
4) FLOAT TIMED DOSSING PANEL	ALARM	TIMER OVERRIDE	LOW LEVEL CUTOUT	5"	8"	26.5"	---	---	---	40"
				5"	8"	26.5"	REDUANT OFF	5"	30.5"	41"

Fig. 1

General Instructions, continued from page 2

16. Secure float cords to top of the float tree to prevent hang-ups (see Fig. 10).

CAUTION Small dimension float switches are recommended in all applications to prevent hang-ups.

17. Place the filter holder assembly down in the pump vault, tilting it toward the pump well side to allow the handle to be placed into the anti-flotation pocket (see Fig. 1 & 13).

18. Place the float tree assembly down into the pump vault. The bottom of the float tree must go into the top of the filter holder. Snap the top of the float tree to the filter holder handle (see Fig. 1 & 12).

19. Connect the pump, floats, alarms and control panels. Follow installation instructions and wiring diagrams supplied with each.

20. After wiring, fill the septic tank with water. This must be done to check the pump, float operating levels and the alarm. **Be sure the floats do not hang up during operation! Do not fully empty the septic tank of water to help prevent float-out.**

Fig. 2

DISCHARGE PIPE ASSEMBLY	HOLE SAW REQUIRED
1"	1-3/4"
1-1/4"	2"
2"	3"

Fig. 3

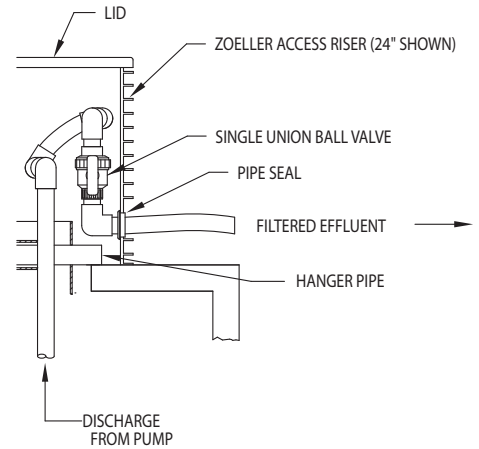

SK1833

Float Tree Assembly

	Top of septic tank to liquid level (bottom of outlet).
	Top of septic tank to bottom of inlet.
	Top of septic tank to inside floor
	STEP system pump vault inlet height (to the center of the inlet).

NOTICE The alarm must be activated at or before the point when the effluent level reaches the bottom of the inlet pipe. If the STEP system is being installed in an existing septic tank, the outlet pipe must be plugged.

Fig. 4

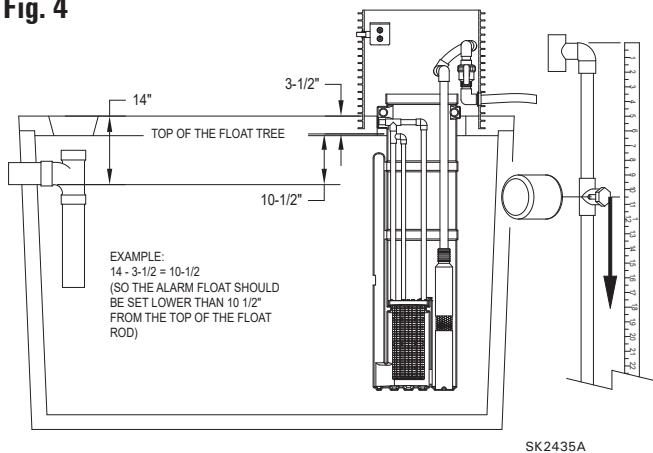
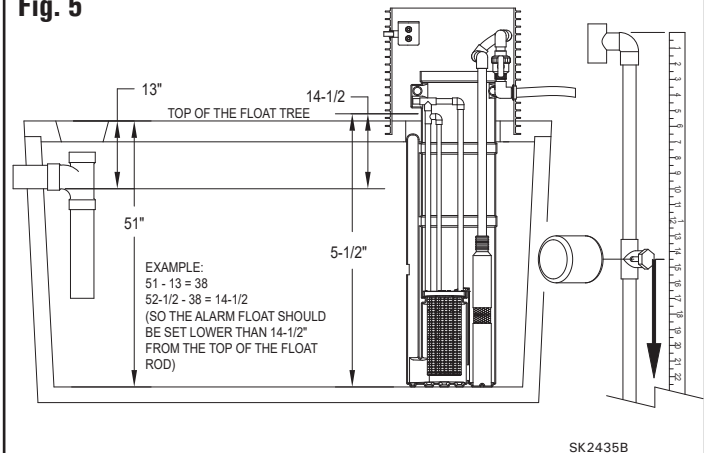

Fig. 5



Float Tree Assembly (continued)

Transferring float locations if the pump vault is hung from the top of the tank:

When the pump vault is hung, the top of the float tree is 3-1/2" below the top of the septic tank. Therefore, any distance measured from the top of the septic tank, minus 3-1/2", will transfer to the top of the float tree (see Fig. 4 for example).

Transferring float locations if the pump vault is placed on the septic tank floor:

When the pump vault is placed on the floor, the top of the float tree is 52-1/2" from the floor. Measure the depth of the tank and record above. Subtract any distance measured from the depth of the tank, then subtract that number from 52-1/2" and the answer will transfer to the top of the float tree (see Fig. 5 for example).

Double Piggyback Application

Fig. 6

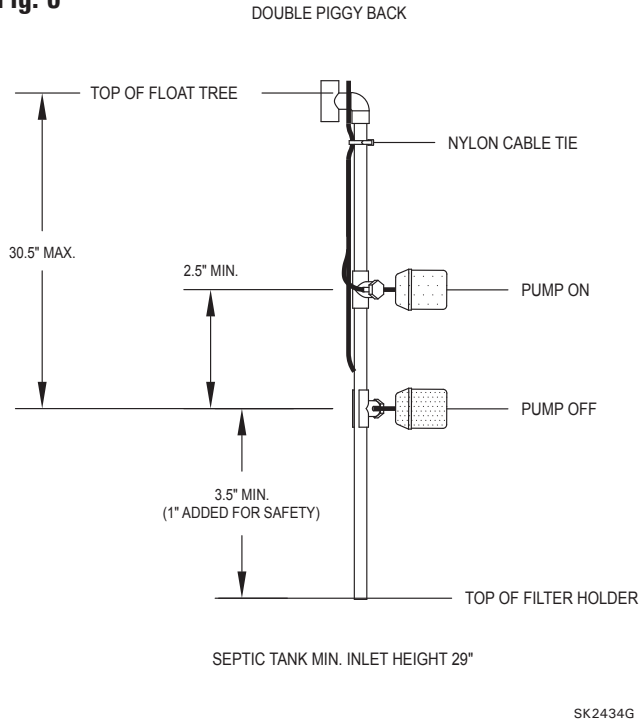

If using the double piggyback float switch option, the floats should be set as follows (see Fig. 6).

Zoeller Pump Company recommends an auxiliary high water alarm when using the double piggyback float switch option. The alarm should be plugged into a different circuit than the pump circuit. Follow the installation instructions provided with the alarm (see Fig. 7).

The alarm must be activated at or before the point when the effluent level reaches the bottom of the inlet pipe.

Record the actual settings measured from the top of the float tree in the table provided for future reference.

Float switch distance from top of the float tree w/o alarm.

	Pump on - Gray (below the bottom of the inlet.)
	Pump off - Black (maximum 30-1/2")

Float switch distance from top of the float tree with alarm.

	Alarm - Black (below or even w/ bottom of inlet)
	Pump on - Gray (varies)
	Pump off - Black (maximum 30-1/2")

Simplex Control Panel Applications

Fig. 7

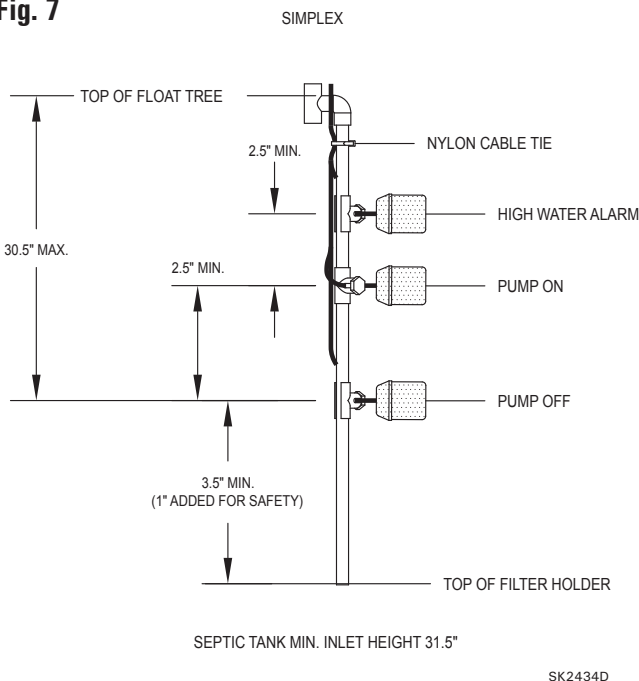

If using a simplex control panel, the floats should be set as follows (see Fig. 7).

The alarm must be activated at or before the point when the effluent level reaches the bottom of the inlet pipe.

Record the actual settings measured from the top of the float tree in the table provided for future reference.

Float switch distance from top of the float tree.

	Alarm - Black (below or even w/ bottom of inlet)
	Pump on - Black (varies)
	Pump off - Black (maximum 30-1/2")

Timed Dosing Applications

Fig. 8

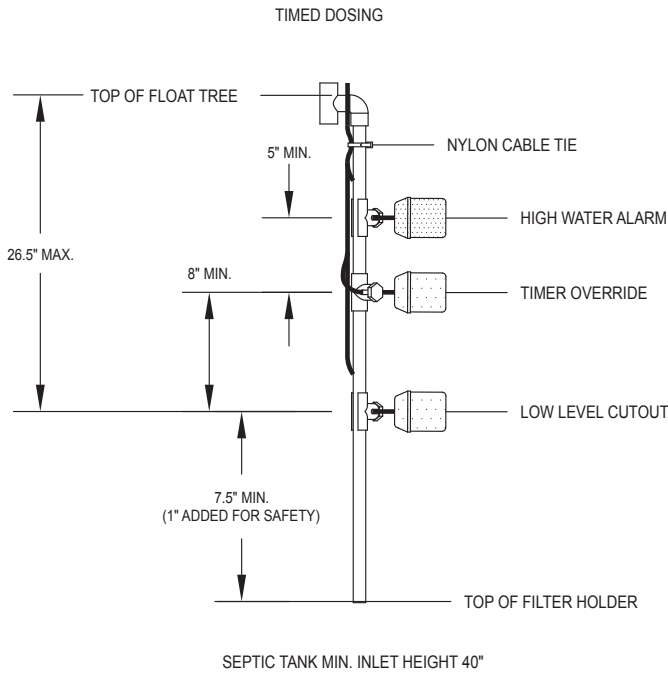

SK2434E

If using a timed dosing panel, the floats should be set as follows: Timed dosing without redundant off (see Fig. 8). Timed dosing with redundant off (see Fig. 9).

If the system is dosing a collection system drain field, media filter, wetland or some other secondary wastewater treatment system, the ideal dosing pattern should be known and applied.

The alarm must be activated at or before the point when the effluent level reaches the bottom of the inlet pipe.

Record the actual settings measured from the top of the float tree in the table provided for future reference.

Float switch distance from top of the float tree w/o redundant off.

	Alarm - Black (below or even w/ bottom of inlet)
	Timer override - Gray (varies)
	Low level cutout - Gray (maximum 26-1/2")

Float switch distance from top of the float tree with redundant off.

	Alarm - Black (below or even w/ bottom of inlet)
	Timer override - Gray (varies)
	Low level cutout - Gray (varies - maximum 25-1/2")
	Redundant off - Black (maximum 30-1/2")

Fig. 9

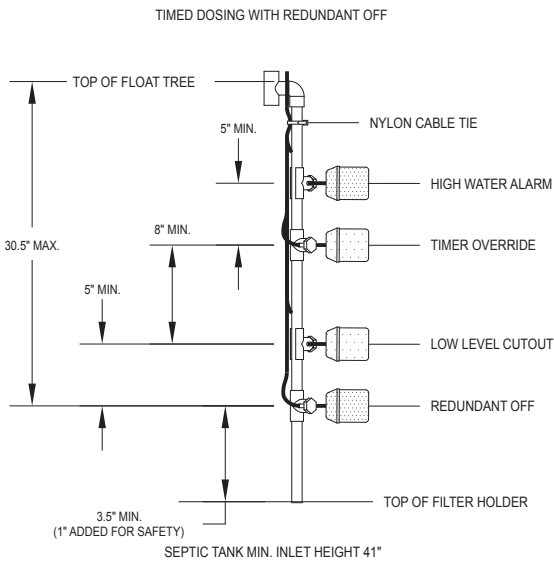

SK2434F

Fig. 10

NOTE: IN ALL CASES, THE LOOSE CORD ABOVE FLOAT CORD HOLDER MUST BE ATTACHED TO THE FLOAT TREE USING TAPE OR NYLON WIRE TIES.

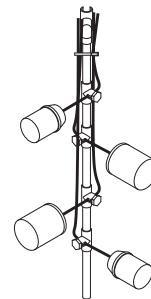

NOTE: FLOATS ARE 90° OPPOSED AND LOCATED OPPOSITE THE INSIDE WALL OF THE PUMP VAULT.

SK2415

Fig. 11

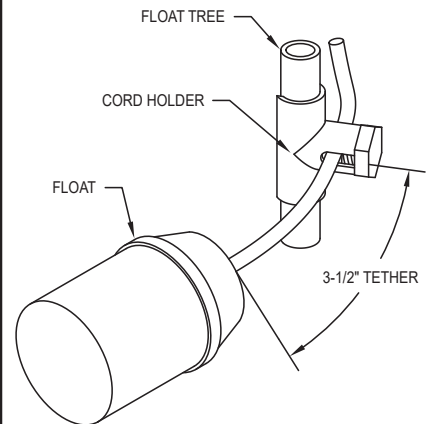

SK2504

Fig. 12

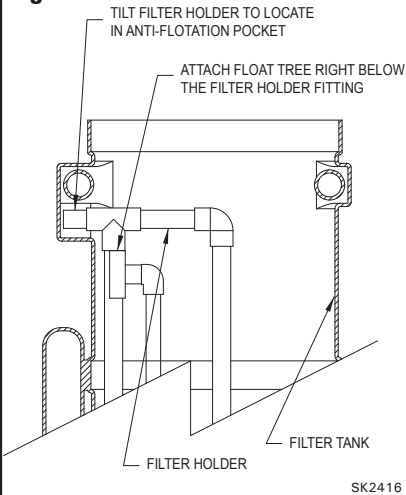

HP	Volts	Ph	Hz	S.F.	Maximum		Locked Rotor Amps	KVA Code	Fuse/Circuit Breaker Amps		Winding Resistance Line to Line
					Amps	Watts			Std.	Delay	
					1/2	115			1	60	
1/2	230	1	60	1.6	6	970	32.2	R	15	8	4.2 - 5.2
3/4	230	1	60	1.5	8	1325	40.7	N	20	10	3.0 - 3.6
1	230	1	60	1.4	9.8	1600	48.7	N	25	11	2.2 - 2.7
1-1/2	230	1	60	1.3	13.1	2250	56.8	L	35	15	1.5 - 1.9
2	230	1	60	1.25	Y 13.2	2650	51.0	G	30	15	1.6 - 2.3 M 5.2 - 7.15 S
					B 11.9						
					R 2.6						
3	230	1	60	1.15	Y 14.0	3650	82.0	G	45	20	.9 - 1.5 M 3.0 - 4.9 S
					B 14.5						
					R 4.5						

Wiring Instructions



⚠ WARNING "Risk of electrical shock" Do not remove the power supply cord and strain relief or connect conduit directly to the pump. Installation and checking of electrical circuits and hardware should be performed by a qualified and licensed electrician.

For your protection, make certain that the pump ground wire is



⚠ WARNING properly connected to the ground wire in the incoming power line. Test for ground at the junction box using an Underwriters Laboratory listed circuit analyzer which will indicate if the power, neutral and ground wires are correctly connected.

In 230 VAC pump installations, one side of the line going to the pump is



⚠ WARNING always hot. This condition exists if the switch is on or off. Install a double pole disconnect on all 230 VAC pump circuits.

GENERAL WIRING RECOMMENDATIONS

- Follow the correct wiring diagram for your system.
- Use an auxiliary alarm with the double piggyback float switch option or any other control method that does not include a high water alarm. Install the alarm inside the house or in a weather protected location per installation instructions with the alarm kit. Make sure the alarm is plugged into a different circuit than the pump circuit.
- If a junction box is being used, follow the installation instructions and wiring directions with the junction box or follow the directions below. All wiring, from the power source to the pump, must conform to the National Electrical Code.
- Be sure to leave a sufficient amount of cord so the filter can be serviced without disconnecting the cordage from the junction box (see maintenance section).

Double Piggyback Float Switch Installations

120 VAC

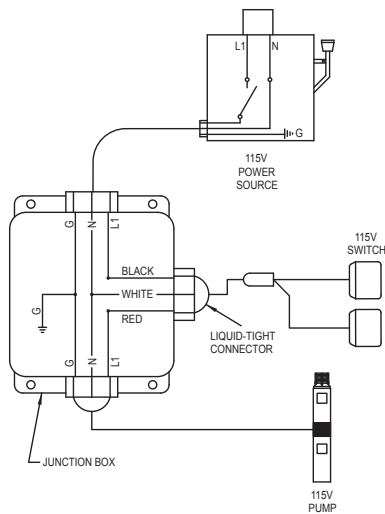

SK1837A

230 VAC

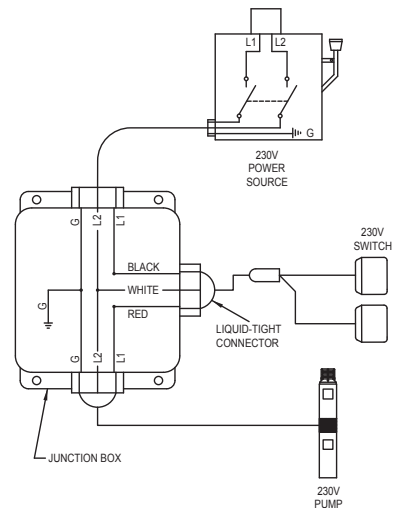

SK1837B

Watertight Junction Box Wiring

The preferred location of the junction box is inside the riser. Some codes require the junction box to be outside the riser. Check with your local health department and electrical inspector before deciding upon the location.

- Junction boxes must be watertight. All wiring that passes through the wall of the box must use watertight connectors and be sealed properly.
- NOTE: See CLO121 for a list of suggested junction boxes. Junction boxes for the high head filter system are fully assembled and are provided with a 3/4" PVC conduit attachment and the appropriate number of cord seals for the pump and floats.

- For junction boxes that are not fully assembled or predrilled, drill a 1-1/8" hole in the box for the 3/4" PVC conduit fitting. Install with washer on the outside of box. Silicone is recommended around the opening for the best seal. Drill a 7/8" hole in the box for each cord seal. Install with washer on the outside of box. Silicone is recommended around each opening for the best seal.

Start-up

Before placing the equipment into operation the following must be checked:

- Septic tank or pump chamber should be pumped and cleaned prior to installation in existing system.
- Septic tank or pump chamber must be watertight.
- Installation needs to be according to instructions.
- Installation should include an easy access riser and tamper resistant lid.
- Filter assembly needs to be in place and secure.
- Float tree needs to be in place, secure and adjusted for proper cycling.
- Make sure float switches are free to move within the basin.
- Be sure electrical connections are watertight and conform to the Uniform Building Code and the National Electrical Code (NEC).
- Fill the septic tank with water and check the system for operation.

After installing the pump into the containment area with adequate

submergence, open the discharge valve fully. Start the unit using manual controls. If flow is appreciably less than rated performance, pump may be air locked. To expel trapped air, jog the unit several times, using the manual controls. If your system has a check valve, make sure the weep hole is clear.

Check float levels during operation and adjust accordingly as needed.

Have a qualified electrician take voltage and current measurements on the black wire of single phase. Record these readings in the space provided in the "Owner's Information" section on the front this manual for future reference.

Be sure to complete all items such as installing the lid on the riser, securely closing the control panel, and checking the system operation have been completed before placing the system into service.

Operation

- If the system is dosing a collection system, drainfield, sand filter, wetland, or some other secondary wastewater treatment system, the ideal dosing pattern should be known and applied.
- The high water alarm will indicate the system needs maintenance. However, regular maintenance by trained professionals is a necessary part of operation.
- During operation, the system owner must continue to use proper septic tank ownership practices. Ground garbage, hair, grease, and non-flushable paper products should be prevented from entering any septic system. These materials will be prevented from entering the drainfield by the filter apparatus, but abuse of the system will result in the need for more frequent servicing.

Maintenance



For your personal safety and health, a high quality pair of rubber gloves are recommended while servicing this unit. For your personal health, always wash your hands with antibacterial soap after servicing this unit.

▲ WARNING Always disconnect pump and panel from its power source before servicing.

GENERAL

Zoeller Pump Company Turbine STEP Systems require periodic maintenance to remain in operational condition. A qualified service technician should carry out the required maintenance. These technicians will not only service the pump unit, but can assess the health of the septic tank.

SERVICE FREQUENCY

- The system contains an effluent filter. This filter will prevent solids larger than 1/16" from entering the pump compartment. The filter will require cleaning. The cleaning interval is determined by household use patterns. For example, a low water use household with no children may need a filter cleaning and inspection on yearly intervals, but a larger family may require filter maintenance every six months, or sooner. The pump tank and pump should be serviced at a minimum each time the septic tank is pumped. Annual inspections by trained professionals are recommended.
- Continual alarm indicator activation between service intervals is a clear indicator that the system is not being serviced often enough. **The alarm indicates a high liquid level and service is required immediately to avoid flooding and back up into the house.**

SERVICING THE UNIT

During filter maintenance, the service technician must perform the following:

- Check the sludge level of the septic tank. If the sludge level approaches 50% of the pump basin inlet height then, the septic tank needs to be pumped.
- The pump should be removed, cleaned, and inspected. Any defective components should be replaced. Inspect and remove any sand, debris, or mud present in the pump vault.
- Inspect the panel for any presence of moisture in enclosure, loose connections, and general component condition.
- Check for proper location and unobstructed float operation.

To remove the filter pack only:

1. The filter pack can be removed on a periodic basis for inspection and servicing without disturbing the pump and piping. Remove the riser cover only **after disconnecting power to both the pump and alarm.**
2. Remove the float tree assembly. Remove filter pack from pump tank by pulling the handle on the filter pack towards the pump(s) and through the opening on the top of tank. Place each component over the septic tank

- opening and hose down thoroughly. The cordage from the junction box to the float tree should be of sufficient length to avoid the necessity of disconnecting the electrical wiring in the junction box. Do not disturb wiring connection unless floats or pump is being replaced or repaired.
3. Reinstall assemblies back in pump tank.
4. Follow **Start-up** procedures located in CLO020 to get system running again.

To remove the entire system:

1. The pump and pump tank must be removed for cleaning and servicing of the septic tank. This provides an opening for pumping out the septic tank. Remove the riser ring cover only **after disconnecting power to both the pump and alarm.**
2. Remove the float tree assembly. Remove filter pack from pump tank by pulling the handle on the filter pack towards the pump(s) and through the opening on the top of pump tank. Hose off each assembly as it is being removed to avoid any spillage of sewage or effluent outside the septic tank.
3. Disconnect the pipe union in the discharge pipe to remove the pump from pump vault. The cordage from the junction box to the pump should be of sufficient length to avoid the necessity of disconnecting the electrical wiring in the junction box. Do not disturb wiring connection unless pump is being replaced or repaired.
4. Lift the pump vault out of the riser and stand upright on ground or level working surface.
5. Place each component over the septic tank opening and hose down thoroughly. Also hose down the inside and outside of pump tank.
6. Reinstall pump tank and related assemblies back in septic tank in reverse order.
7. Follow **Start-up** procedures located in CLO020 to get system running again.

Replacement Parts for Zoeller Pump Company Turbine STEP System

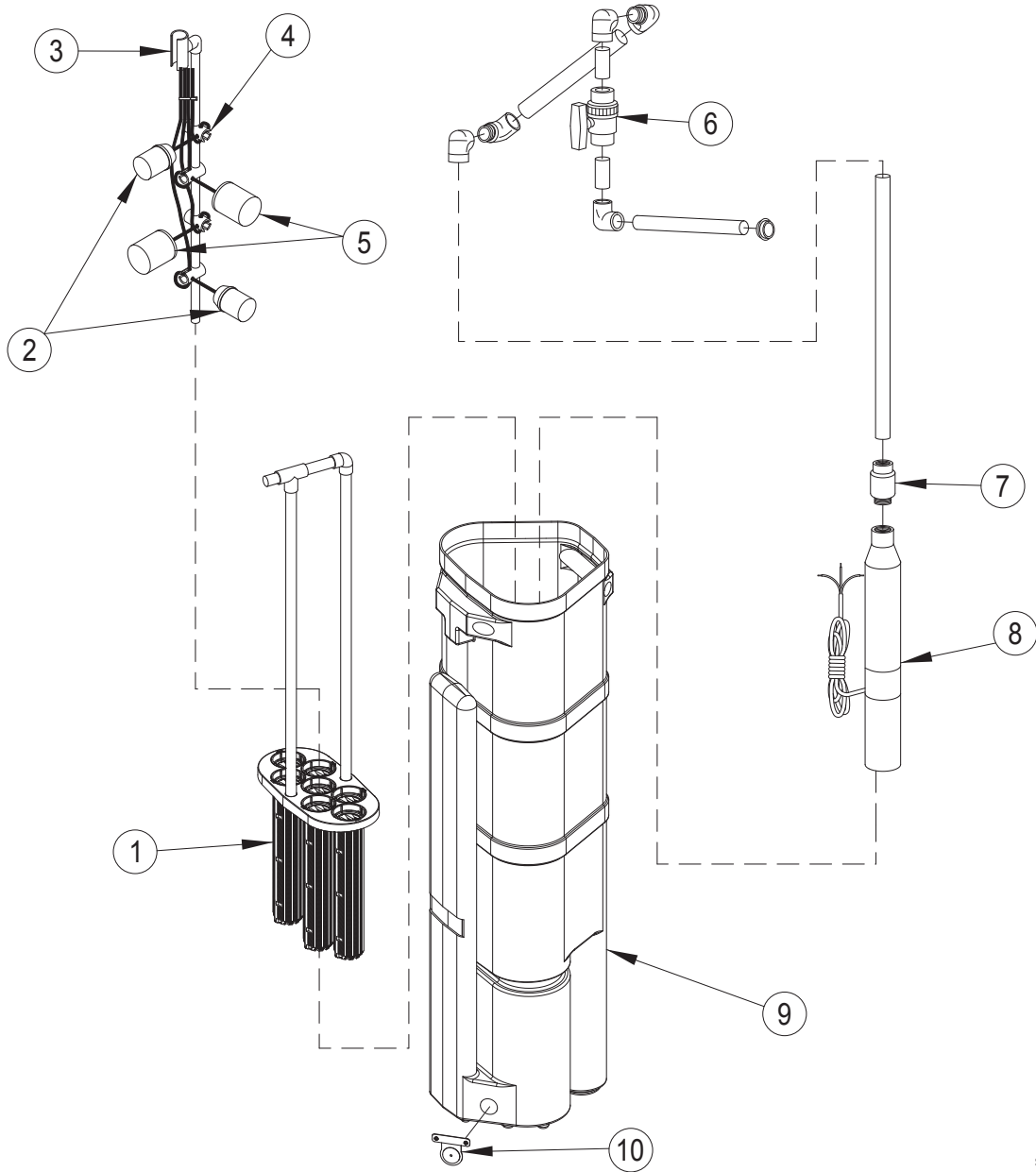

SK2417

SERVICE PARTS LIST TURBINE EFFLUENT STEP SYSTEM

PART NAME	PART NUMBER 4/04 THRU CURRENT
1 FILTER ASSEMBLY	016140
2 FLOAT (NARROW ANGLE)	011833
3 FLOAT TREE (TEE ONLY)	10-1681
4 FLOAT HOLDER	013940
5 FLOAT (WIDE ANGLE)	004066
6 DISCHARGE ASSEMBLY	170-0082
7 EXTERNAL CHECK VALVE	30-0187
8 PUMP	consult factory
9 PUMP TANK*	016452
10 FLAPPER ASSEMBLY	016141

The accompanying parts list is provided for ordering service parts. Please have pump model number and date code ready for immediate service.

*NOTE: Replacement tank will require field cutting of the inlet.

ENGINEERED SYSTEMS

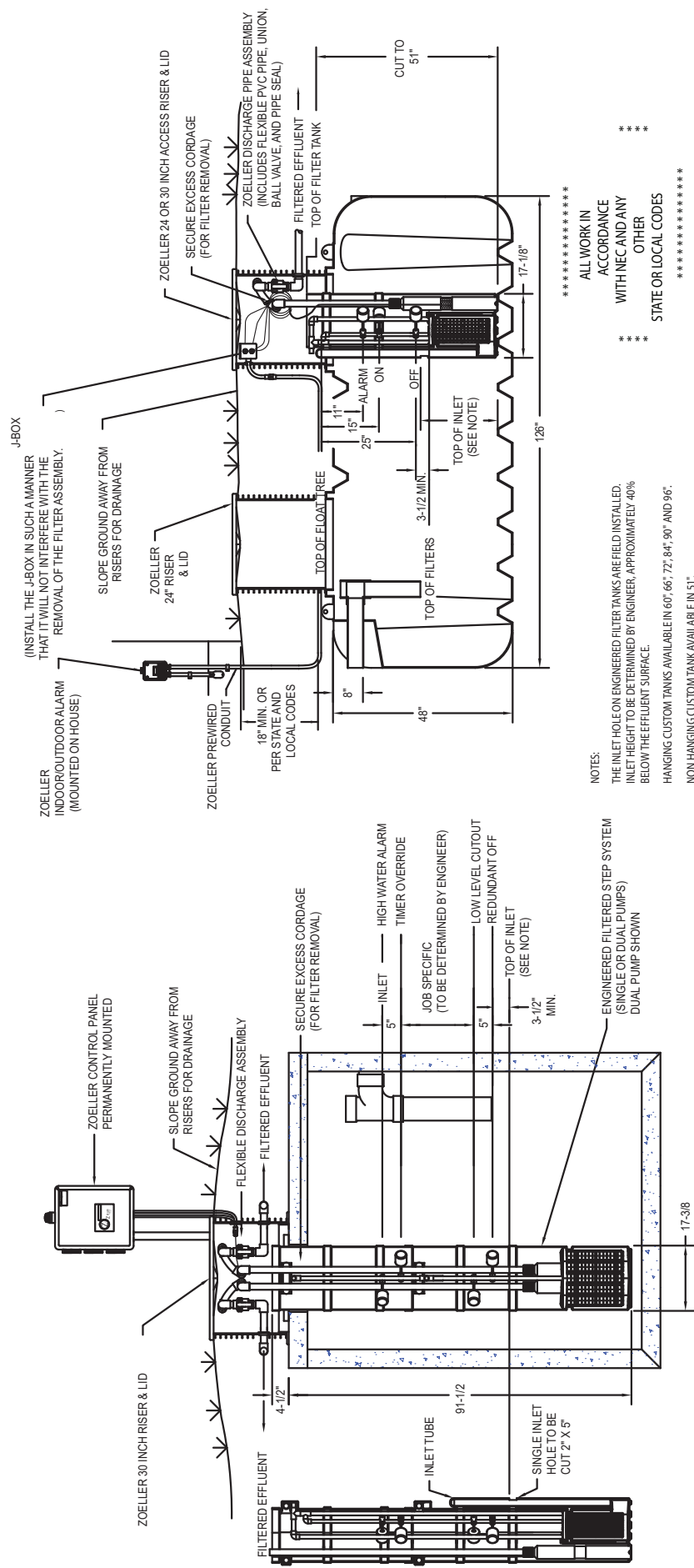

 ALL WORK IN ACCORDANCE WITH NEC AND ANY OTHER STATE OR LOCAL CODES *****

NOTES:
 THE INLET HOLE ON ENGINEERED FILTER TANKS ARE FIELD INSTALLED. INLET HEIGHT TO BE DETERMINED BY ENGINEER, APPROXIMATELY 40% BELOW THE EFFLUENT SURFACE.
 HANGING CUSTOM TANKS AVAILABLE IN 60", 66", 72", 84", 90" AND 96".
 NON HANGING CUSTOM TANK AVAILABLE IN 51".

Notes

All Zoeller Pump Company products must be installed and maintained in accordance with all applicable codes. Product information presented here reflects conditions at time of publication. Consult factory regarding discrepancies or inconsistencies.



MAIL TO: P.O. BOX 16347 • Louisville, KY 40256-0347
SHIP TO: 3649 Cane Run Road • Louisville, KY 40211-1961
Tel: (502) 778-2731 • 1 (800) 928-PUMP

Trusted. Tested. Tough.®

Visit our website:
zoellerpumps.com