

NOTICE TO INSTALLER: Instructions must remain with installation.

Trusted. Tested. Tough.®

Register your  
Zoeller Pump Company  
Product on our website:  
<http://reg.zoellerpumps.com/>



FM3315  
0725  
Supersedes  
0724

MAIL TO: P.O. BOX 16347 • Louisville, KY 40256-0347  
SHIP TO: 3649 Cane Run Road • Louisville, KY 40211-1961  
Tel: (502) 778-2731 • 1 (800) 928-PUMP

Visit our website:  
[zoellerpumps.com](http://zoellerpumps.com)

Product information presented here reflects conditions at time of publication. Consult factory regarding discrepancies or inconsistencies.

Patent No. D740329



<b>DATE INSTALLED:</b>
<b>MODEL NUMBER:</b>

### AQUANOT KEY 507/73

PREASSEMBLED SUMP PUMP SYSTEM WITH BATTERY BACKUP

MODEL 507 - 12 V DC BATTERY BACKUP SYSTEM

WITH 115 V AC POWERED SUMP PUMP

MODEL M73

## INSTALLATION INSTRUCTIONS

157391-E

### PREINSTALLATION CHECKLIST

1. Inspect your pump. Occasionally, products are damaged during shipment. If the unit or any of the parts are damaged, contact your dealer before using.
2. Carefully read the literature provided to familiarize yourself with specific details regarding installation and use. These materials should be retained for future reference.



#### WARNING

SEE BELOW FOR LIST OF WARNINGS

1. Testing for ground. As a safety measure each electrical outlet should be checked for ground using an Underwriters Laboratory listed circuit analyzer, which will indicate if the power, neutral and ground wires are correctly connected to your outlet. If they are not, call a qualified, licensed electrician.
2. For your protection, always disconnect the power supply from its power source before handling the components of your DC backup pump or the primary pump.
3. Installation and servicing of electrical circuits and hardware should be performed by a qualified, licensed electrician.
4. All electrical and safety codes must be followed including the National Electrical Code and all applicable local codes.
5.  It is the owner's responsibility to check the battery and battery connection at least once a month. Batteries contain acid, and caution must be taken when handling.
6. Risk of electric shock. These pumps have not been investigated for use in swimming pools and marine areas.
7. Prop 65 Warning for California residents: Cancer and Reproductive Harm-[www.P65Warning.ca.gov](http://www.P65Warning.ca.gov).

This equipment has been tested and found to comply with the limits for a class B digital device, pursuant to part 15 of the FCC Rules. These limits are designed to provide reasonable protection against harmful interference in a residential installation. This equipment generates, uses and can radiate radio frequency energy and if not installed and used in accordance with the instructions, may cause harmful interference to radio communications. However, there is no guarantee that interference will not occur in a particular installation. If this equipment does cause harmful interference to radio or television reception, which can be determined by turning the equipment off and on, the user is encouraged to try to correct the interference by one or more of the following measures:

- Reorient or relocate the module/ product.
- Increase the separation between the equipment and module / product.
- Consult the dealer or an experienced radio / TV technician for help.

#### CAUTION

SEE BELOW FOR LIST OF CAUTIONS

1. Make sure there is a properly grounded 115 V receptacle available. We recommend the primary sump pump and controller be on separate circuits. The location must be within 6' (1.8 m) of the control box and battery. The power supply for your DC control system plugs directly into the 115 V outlet. **DO NOT USE AN EXTENSION CORD.**
2. Make sure the 115 V electrical supply circuit is equipped with fuses or circuit breakers of proper capacity.
3. DC emergency pumps are designed for handling clear water. Do not use in septic tanks to pump effluent or in sewage pits to pump sewage.
4. Repair and service of your DC backup system should be performed by an authorized service station.
5. The installation of DC automatic backup pumps requires the use of a variable level float switch for operation. It is the responsibility of the installing party to ensure that the float switch will not hang up on the pump apparatus or pit peculiarities and is secured so the pump will turn "on" and "off".
6. For indoor use only.

**CAUTION** Turbulence caused by high-velocity incoming water can cause sump pumps to airlock. If this condition exists, the incoming water must be baffled to avoid excessive turbulence.

**REFER TO WARRANTY ON PAGE 2.**

---

## LIMITED WARRANTY

---

Manufacturer warrants, to the purchaser and subsequent owner during the warranty period, every new product to be free from defects in material and workmanship under normal use and service, when properly used and maintained, for a period of 3 years from date of purchase by the end user. Zoeller batteries have a 3 year warranty. Proof of purchase is required. Parts that fail within the warranty period, that inspections determine to be defective in material or workmanship, will be repaired, replaced or remanufactured at Manufacturer's option, provided however, that by so doing we will not be obligated to replace an entire assembly, the entire mechanism or the complete unit. No allowance will be made for shipping charges, damages, labor or other charges that may occur due to product failure, repair or replacement.

This warranty does not apply to and there shall be no warranty for any material or product that has been disassembled without prior approval of Manufacturer, subjected to misuse, misapplication, neglect, alteration, accident or uncontrollable act of nature; that has not been installed, operated or maintained in accordance with Manufacturer's installation instructions; that has been exposed to outside substances including but not limited to the following: sand, gravel, cement, mud, tar, hydrocarbons, hydrocarbon derivatives (oil, gasoline, solvents, etc.), or other abrasive or corrosive substances, wash towels or feminine sanitary products, etc. in all pumping applications. The warranty set out in the paragraph above is in lieu of all

other warranties expressed or implied; and we do not authorize any representative or other person to assume for us any other liability in connection with our products. Contact Manufacturer at, 3649 Cane Run Road, Louisville, Kentucky 40211, Attention: Customer Support Department to obtain any needed repair or replacement of part(s) or additional information pertaining to our warranty.

**MANUFACTURER EXPRESSLY DISCLAIMS LIABILITY FOR SPECIAL, CONSEQUENTIAL OR INCIDENTAL DAMAGES OR BREACH OF EXPRESSED OR IMPLIED WARRANTY; AND ANY IMPLIED WARRANTY OF FITNESS FOR A PARTICULAR PURPOSE AND OF MERCHANTABILITY SHALL BE LIMITED TO THE DURATION OF THE EXPRESSED WARRANTY.**

Some states do not allow limitations on the duration of an implied warranty, so the above limitation may not apply to you. Some states do not allow the exclusion or limitation of incidental or consequential damages, so the above limitation or exclusion may not apply to you.

This warranty gives you specific legal rights and you may also have other rights which vary from state to state.

In instances where property damages are incurred as a result of an alleged product failure, the property owner must retain possession of the product for investigation purpose.

---

## EASY DO'S & DON'TS FOR INSTALLING A SUMP PUMP

---

1. DO read thoroughly all installation material provided with the system.
2. DO inspect system for any visible damage caused by shipping. Contact dealer if system appears to be damaged.
3. DO clean all debris from the sump. Be sure that the pump will have a hard, flat surface beneath it. DO NOT install on sand, gravel or dirt.
4. DO be sure that the sump is large enough to allow proper clearance for the level control switch(es) to operate properly.
5. DO always disconnect pump from power source before handling.
6. DO always connect to a properly grounded and protected circuit.
7. DO NOT ever cut, splice, or damage power cord (only splice in a watertight junction box).
8. DO NOT carry or lift pump by its power cord.
9. DO NOT use an extension cord with a sump pump.

10. DO install a union in the discharge line.
11. DO NOT use a discharge pipe smaller than the pump discharge.
12. DO NOT use a sump pump as a trench or excavation pump, or for pumping sewage, gasoline, or other hazardous liquids.
13. DO test system immediately after installation to be sure that the system is working properly.
14. DO cover sump with an adequate sump cover.
15. DO review all applicable local and national codes and verify that the installation conforms to each of them.
16. DO consult manufacturer for clarifications or questions.
17. DO inspect and test system for proper operations at least every three months.

---

## RECOMMENDED INSTALLATION FOR ALL APPLICATIONS

---

1. Electrical wiring and protection must be in accordance with National Electrical Code and any other applicable state and local electrical requirements.
2. All installations require a basin cover to prevent debris from falling into the basin and to prevent accidental injury.
3. Securely tape or clamp power cord to discharge pipe, clear of the float mechanism(s).
4. Use full-size discharge pipe.
5. Basin must be in accordance with applicable codes and specifications. We recommend the primary sump pump and controller be on separate circuits.

6. Pump must be level and float mechanism(s) clear of sides of basin before starting pump. Float switch may be repositioned as needed.
7. Basin must be clean and free of debris after installation.
8. Gate valve or ball valve to be supplied by installer and installed according to any and all codes.
9. Gas tight seals required to contain gases and odors.
10. Vent gases and odors to the atmosphere through vent pipe.
11. Install Zoeller Pump Stand (Model 10-2421) under pump to provide space for settling dirt, sand, or grit".

## DESCRIPTION

This system is a combination of a primary sump pump and a backup pump to your primary sump pump. It is designed to protect against flooding during power outages or primary pump failure. This system is unique in that it is self-testing. The controller has smart diagnostics built in. If the DC pump is unplugged or jammed, for example, a fault alarm will result. If the float switch is missing/unplugged, it will create an immediate alarm condition. The controller will recognize the difference between a pump that is pumping air vs. a pump that is pumping water. This will lead to behaviors designed to purge air and remedy an air lock situation. The controller also has smart float logic that is designed to prevent a continuous running pump (or run dry pump condition). Zoeller uses a normally open operational float switch. The advanced technology hardware and firmware in the Key controller will recognize, attempt to remedy, and alarm for many conditions that have not previously been possible. The controller will automatically charge and maintain the battery in a way designed to extend battery life.

<b>PRIMARY PUMP</b>	Construction	Cast iron & plastic, premium seals
	Performance	30 GPM at 10' head
<b>DC PUMP</b>	Construction	Non-corrodible plastic
	Performance	11 GPM at 10' (113 LPM at 3 m) at 12.7 volts
	Continuous Running Time	6.5 hours with recommended battery
	Duty Cycle of 10%	2 days
	Connection	9' (2.7 m) cord with connector
<b>CONTROLLER</b>	Construction	ABS plastic
	Power Requirement	115 V 15 amp circuit
	Consumption	Up to 0.8 amps at 115 V
	Charger output	1.6 amp
	Connections	8' (2.4 m) AC power cord, 6' (1.8 m) DC charging cable, connections for pump, operation switch
<b>BATTERY BOX</b>	Construction	Non-corrodible plastic
	Safety	Snap tight lid, keeps battery safe and clean

\* When AC power is available, the controller will replace the power used by the pump once the pump shuts off.

## PERFORMANCE

The DC pump performance with fully charged 12 V battery

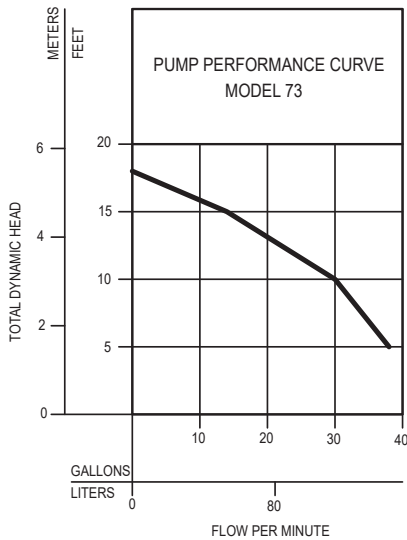

### 507 DC PUMP

Total Dynamic Head	5 ft (1.5 m)	10 ft (3.0 m)	14.5 ft (4.4 m)
Flow GPM (LPM)	22 (83)	11 (41)	Shut-off Head

### TOTAL DYNAMIC HEAD/FLOW PER MINUTE DEWATERING ONLY

MODEL		73	
Feet	Meters	Gal.	Liters
5	1.5	38	144
10	3.0	30	114
15	4.6	14	53
Shut-off Head:		18 ft. (5.5 m)	

The DC controller is equipped with a 10 amp charger for maintaining the battery in a ready state and recharging the battery after use when AC power is restored. Time for recharge depends upon the amount of power consumed by the pumping cycle during the AC power interruption. The system may return to the charged LED position in a very short period of time. A completely drained battery may require up to 24 hours for full recharge.

## BATTERY SELECTION

The DC emergency pump system requires a good quality, 12 volt battery to obtain maximum pumping time during a power outage. A deep-cycle, 12 volt, 90 amp-hour or larger marine battery is recommended. A 100+ amp hour battery will provide approximately 5.5 hours or more of continuous pumping time in a sump pump installation with 8' (2.4 m) of head pressure. In most installations, the pump runs intermittently and the battery life is extended accordingly. Batteries with top terminals are recommended for ease of installation. "Wet" cell batteries contain acid, and proper precaution must be taken when handling. Battery box will accommodate a maximum battery size of 13-1/2" (34.3 cm) Length x 7" (17.8 cm) Width x 9-1/2" (24.1 cm) Height. AGM batteries also recommended. Do not use gel batteries or automotive batteries.

---

## INSTALLATION

---

1. The installation kit includes the necessary fittings and parts needed to install as in Figure 1. A check valve is incorporated in the discharge of the backup pump.
2. Select location for battery and control charger. Control charger must be within 6' (1.8 m) of a 115 V wall outlet and within 6' (1.8 m) of pump and basin. We recommend the primary sump pump and controller be on separate circuits.
3. Make certain the float switch clamp is tight on the pipe to avoid slippage. Ensure that the "off" level of the float is 1" (25 mm) minimum above the discharge tee of the DC backup pump (see figure 1). Position pumps in the sump and move float up and down, making sure of free movement without interference from any obstructions inside the sump or lid. Very shallow sumps may require some adjustment to avoid overflowing or backing up of water into the sump inlet. The float switch can be moved on the discharge pipe or the rubber stops can be adjusted as necessary. Cut extra float rod length below lower float stop to prevent debris from interfering with float operation (see Figure 2).
4. Mount the Key controller to the wall. If more convenient, the control charger may be set on a nearby shelf or ledge. The Key controller can also be mounted to the mounting posts on top of the battery box lid.
5. Connect the leads from the control charger to the battery terminals. White positive (+) lead to positive terminal and black negative (-) lead to negative battery terminal. Upon proper connection, test alarm will sound. Press alarm reset to silence. This indicates proper charger to battery connection.  
**CAUTION** Correct battery hook up is essential for operation of the system. Use nuts supplied with battery and eyelet connectors on battery wire leads. On batteries with different sized posts, the positive terminal is the larger post, 3/8" (10mm) diameter. The smaller post, 5/16" (8mm) diameter is the negative terminal. This will be indicated on the battery. Apply grease to the terminals to help prevent corrosion.
6. Connect the plugs for the pump, operational switch, and power supply into the appropriate receptacles on the controller.
7. Close battery box and secure cover.
8. Plug the control power cord into the 115 V wall outlet. The primary sump pump and the control charger should be on separate circuits.
9. Reconnect power to primary sump pump.

---

## INITIAL START-UP AND OPERATION

---

It is important to understand that the Key controller is an advanced technology product that has capabilities beyond those seen in other battery backup products. For those unfamiliar with the product, behaviors in the Key may initially seem unusual. For example, the controller is able to recognize potential air lock situations and remedy with an on/off/on/off/on routine proven to purge the problematic air from the pump.

The LEDs have specific patterns and behaviors that differ from other products on the market. For example, the DC Pump LED will stay Yellow after pumping water, alerting the homeowner of a DC pump-run event. If the pump runs and does NOT pump water (for example when lifting the float manually as a test with the pump above the waterline), the LED will not stay Yellow. This is meant to be an aid to the installer in order to test the pump without having to reset it each time.

When the float is disconnected, the alarm will sound and the Red Float Status LED will blink indicating that the float state has changed. Before leaving the installation site, the installer must initiate a Reset by holding the Silence button for 3 seconds. This will ensure that all systems are in a standby, ready state.

1. Test the installation for leaks by running water into the sump, allowing for normal operation of the primary pump.
2. Check the controller. The System Ready light will be green when the unit is plugged into the 115 V wall outlet. The battery will indicate its condition when the controller has DC power. When the unit is first plugged in, all lights will flash and alarm will sound to verify all lights and the alarm work. The Key controller powers up expecting both switches to be connected. If one or both float switches are not connected, there will be various alarms depending on what is connected. If this occurs, simply plug in the switch and then reset the alarms by holding the Silence button for 3 seconds. Note that the charger may not begin charging for several minutes.
3. Disconnect the primary pump from its power source before touching any component in the sump pit.
4. Lift the Key's operational float switch. After 1 second "splash activation prevention" delay, the DC backup pump will run, and the alarm will sound after 1 more second. Lower the operational float switch after the alarm sounds. Take care that the intake of the DC pump is set above the intake of the primary pump. If water was pumped, the Yellow DC Pump LED and alarm will remain on, indicating that the pump ran and pumped water. The alarm can be silenced by pressing the Silence button. The yellow LED can be cleared by holding the Silence button for 3 seconds to reset. If the operational float is held on while there is no water to pump, the controller will turn the pump on and off a few times before running the pump continuously. This is to purge a suspected air lock. When the float is lowered, the pump will turn off, but the yellow DC Pump LED will not persist. The yellow DC Pump LED and alarm only stay on if the pump actually pumps water. The intention of this behavior is so the installer can turn the pump on and off for testing during installation without repeatedly having to reset the controller. If the operational float is removed/unplugged, there will be an alarm and a red flashing Float Status LED until silenced or remedied.  
**CAUTION** Continuous dry running may cause overheating and damage the pump seals. Upon release of the float switch, the pump will shut off. Be certain there are no obstructions around the float or stem that will prevent the switch from turning off.
6. Complete the final testing of your installation by ensuring the primary pump is still disconnected from power. Then, unplug the Key controller from the 115 V wall outlet. Run water into the sump until the DC backup pump is activated by the operational float switch. Check all connections for leaks.
7. Press the Silence button when the pump is running. This will silence the alarm. The pump will continue to run until the operational float is deactivated.
8. Reconnect the controller and the primary pump to the AC wall outlets. The primary pump may come on, lower the water level in the sump back to its normal operating level, and shut off. Both primary and backup systems are now ready for use. Hold silence button for 3 seconds to reset the Key controller.
9. The battery LED will be yellow during normal charging operation. See page 6 and 7 for a description of controller functions.

# TYPICAL INSTALLATION

**FIGURE 1**  
DC PUMP INSTALLED IN LINE WITH SUBMERSIBLE PUMP

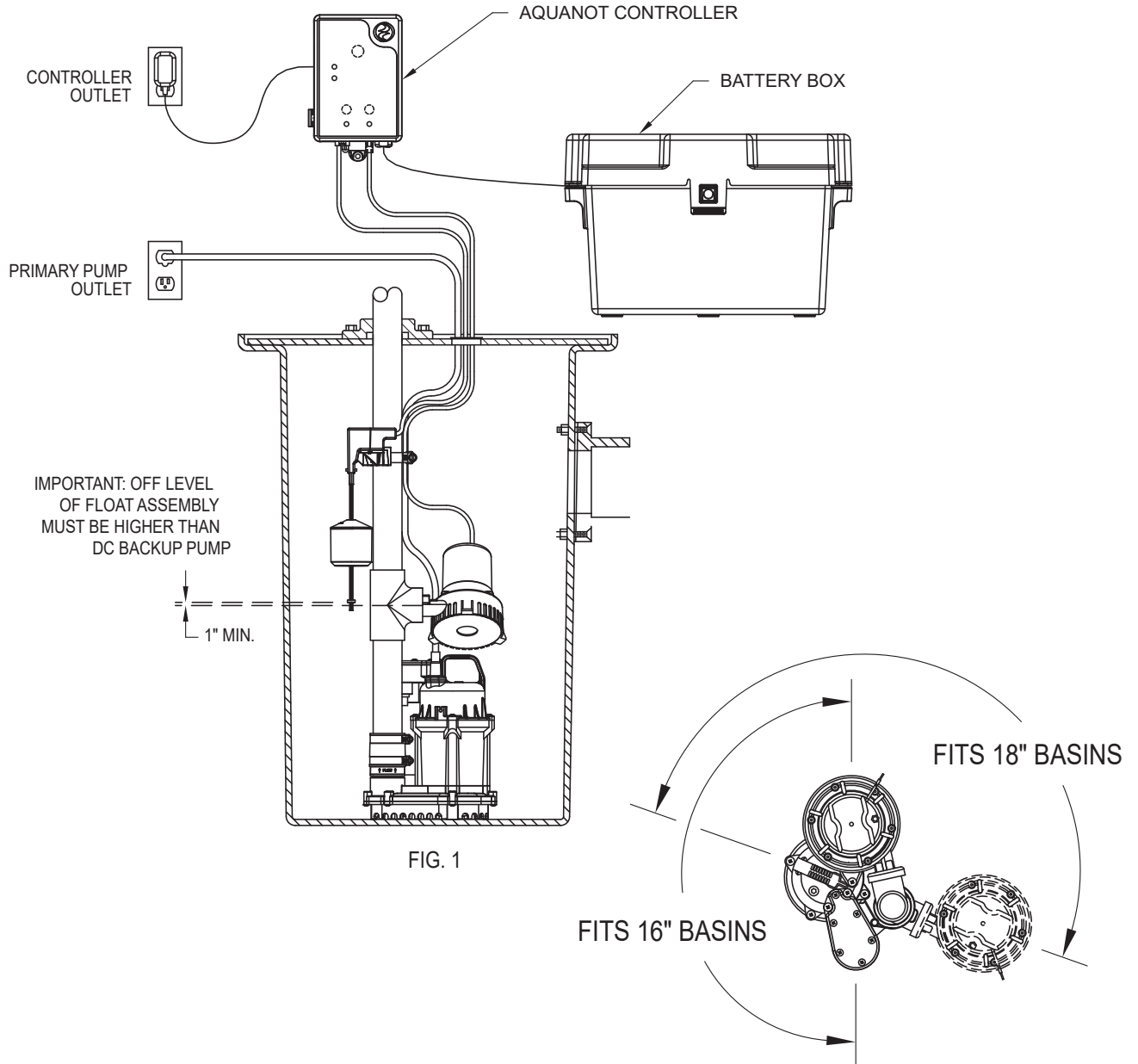

SK3260

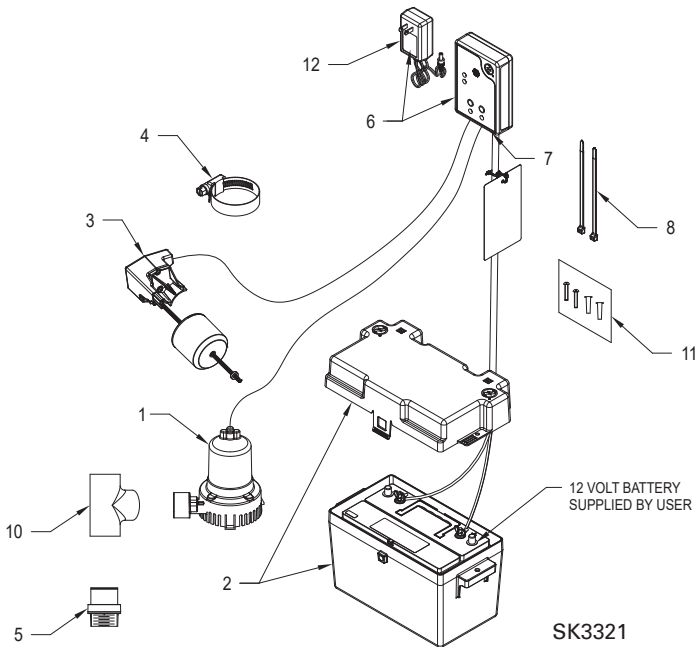

MODEL 507 KEY PARTS LIST			
ITEM	DESCRIPTION	QTY	507-G 06/21 THRU CURRENT
1	Pump 12 V DC / backup (service part)	1	156790
2	Battery box asm (box and cover)	1	10-0764
3	Operational float switch	1	157927
4	Clamp, #28 worm-SS (float switch)	1	004287
5	Valve, check / 1.5" (DN40) Inline / vertical	1	153772
6	Key controller	1	157387
7	Fuse, 30 amp automotive	2	016918
8	Cable Ties 14.5"	1	157389
9	M73 115V/1P/60Hz/cCSAus (not pictured)	1	73-0001
10	Fitting, PVC 1-1/2" (DN40) tee/SCH 40 (pressure fitting)	1	153766
11	Hardware pak, charger /switch mode	1	152864
12	Power supply	1	157388

## AQUANOT® KEY™ FLOAT SWITCH

## AQUANOT® KEY™ CONTROLLER

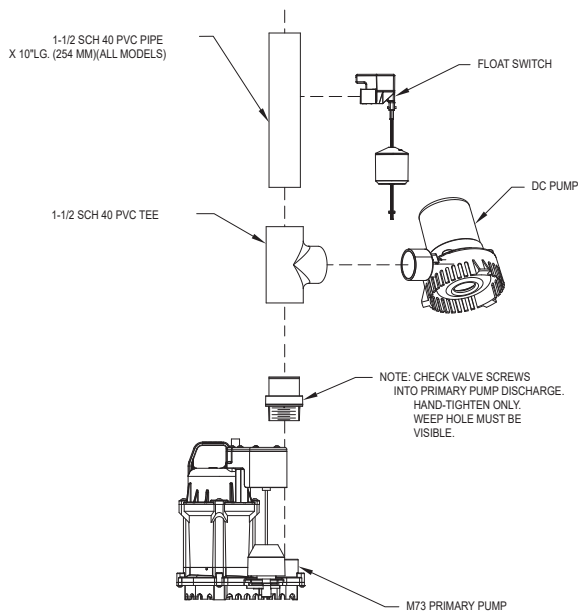
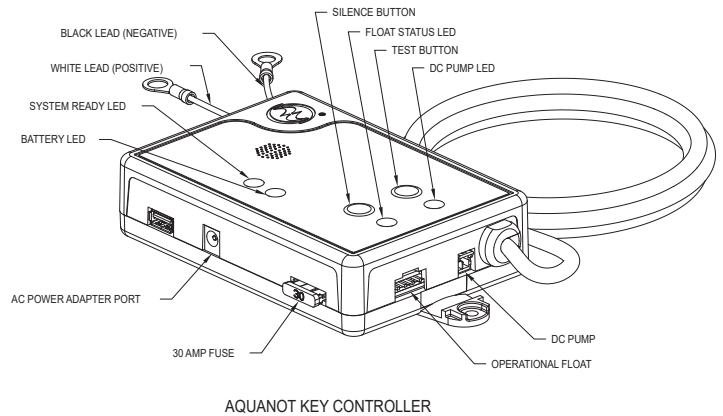
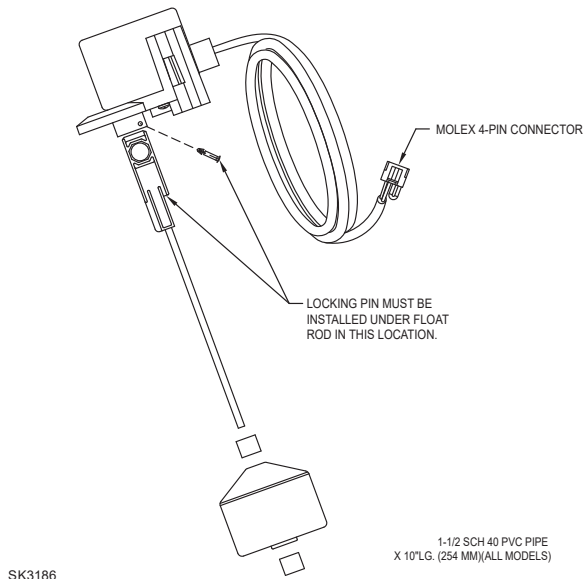

## TROUBLESHOOTING INFORMATION

To perform a Factory Reset, hold the Silence and Test buttons together. A Factory Reset restores all settings to their original setting. Be sure all switches, pump, battery and AC connections are good before the Factory Reset.

1. DC Pump won't run.
  - (a) Check for proper connections.
  - (b) Check all wire terminal points. Clean if required.
  - (c) Check for low battery. Service battery if required.
  - (d) Check 30 amp fuse on controller. If fuse is blown, replace with 30 amp automotive blade fuse.
  - (e) Remove pump. Check for obstruction in pump preventing impeller from rotating.
  - (f) Float switch was not "on" for more than 1 second. A quick up/down of a switch will not turn the pump on because the controller is designed with "splash activation protection".
  - (g) During a float fault, the operational float is disregarded until the controller is reset.
2. Pump runs but moves very little or no water.
  - (a) Check for low battery. Battery will recharge if green System Ready LED indicates power has been restored and the float switch is in the off position.
  - (b) If immediate usage is required, remove and replace dead battery with a fully recharged battery.
  - (c) Under certain conditions the pump may continue to run on a low battery without sufficient power to remove water. Pump will stop running once battery is below minimum voltage threshold.
  - (d) **CAUTION** Weak batteries can be recharged but may not store sufficient energy for full service. A weak, recharged battery can only be detected by reduced pumping time or by professional load testing equipment. The battery should be checked by a qualified battery dealer.
    - (e) Verify pump is connected completely.
    - (f) Check to make sure pump weep hole is clear and unit is not airlocked.
    - (g) Make sure discharge piping is not blocked.
3. Pump cycles too frequently.
  - (a) Check positions of rubber stops on the operational float rod and adjust if necessary.
4. Pump runs, but pumps water intermittently.
  - (a) Pump may be air locking. Check flow of water incoming to sump. If water is entering the sump at a high velocity creating a turbulent condition, a mixture of air and water may cause a complete or partial air lock and reduce or stop the flow of water in the discharge pipe.
  - (b) Baffle the incoming stream of water to reduce turbulence. Diverting water stream against wall of basin usually corrects an air lock problem.
5. Water level stays high. DC Pump continues to run.
  - (a) Battery is low or pump may have blockage in screen, impeller, or piping system.
  - (b) If power has been restored and water in sump remains high check primary pump. Service if required.
6. Alarm sounds during battery recharge cycle.
  - (a) To silence alarm if alarm will not reset, unplug the charger from 115 V wall outlet, then disconnect the black lead from charger on negative (-) battery post. Check battery. Replace if necessary. Reconnect and refer to Installation Instructions.

## SERVICE CHECKLIST- PRIMARY PUMP



**WARNING** **ELECTRICAL PRECAUTIONS-** Before servicing a pump, always shut off the main power breaker and then unplug the pump - making sure you are wearing insulated protective sole shoes and not standing in water. Under flooded conditions, contact your local electric company or a qualified licensed electrician for disconnecting electrical service prior to pump removal.

**WARNING** Submersible pumps contain oils which becomes pressurized and hot under operating conditions. **Allow 2-1/2 hours after disconnecting before attempting service.**

CONDITION	COMMON CAUSES
A. Pump will not start or run.	Check fuse, low voltage, overload open, open or incorrect wiring, open switch, impeller or seal bound mechanically, motor or wiring shorted. Float assembly held down. Switch damaged or out of adjustment.
B. Motor overheats and trips overload or blows fuse.	Incorrect voltage, negative head (discharge open lower than normal) impeller or seal bound mechanically, motor shorted.
C. Pump starts and stops too often.	Float switch tether length too short, check valve stuck open, or none installed in long distance line, overload open, bidding, sump pit too small.
D. Pump will not shut off.	Debris under float assembly, float bound by basin sides or other, switch, damaged or out of adjustment.
E. Pump operates but delivers little or no water.	Check inlet, strainer housing, discharge pipe, and vent holes for obstructions. Discharge head exceeds pump capacity. Low or incorrect voltage. Incoming water containing air or causing air to enter pumping chamber.
F. Drop in head and/or capacity after a period of use.	Increased pipe friction, clogged line or check valve. Abrasive material and adverse chemicals could possibly deteriorate impeller and pump housing. Check discharge line. Remove base and inspect.
G. If tank or fittings leak.	Carefully tighten pipe joints (use pipe dope) and screws. Check gasket location, tighten lid evenly. Do not over tighten fittings or screws.

**If the above checklist does not uncover the problem, consult the factory - Do not attempt to service or otherwise disassemble pump.**

## KEY™ CONTROLLER FUNCTIONS

There are two buttons on the front of the controller.

**- Silence/Reset**

- Press to silence current alarms for 24 hours.
- Hold for longer than 3 seconds to reset alarm. Reset will clear flashing light on unit.

**- Test**

- Will run the pump to determine if amp draw of pump is in range.
- Controller is factory programmed to self-test the pump for several seconds every 24 hours.
- Pressing the test button will start the 24-hour timer for self-testing.

Note: Holding both the silence/reset and test button at the same time for 5 seconds will cause a factory reset on the controller.

AQUANOT® KEY™			
LED INDICATOR	SOLID	FLASHING	OFF
System Ready	No Faults (Green)	AC off with no faults (Green)	--
Battery	Charged (Green)	Low Battery (Red)	No AC Power
	Charging (Yellow)		
	Bad Battery (Red)		
DC pump	Pump Ran (Yellow)	Pump Running (Yellow)*	--
		Pump Fault (Red)	
Float Status	--	Float Fault (Red)	--

\*Note: will not persist if pump didn't pump water

See also the laminated label affixed to the controller's cord. This cord label also describes LED and button functionality.

## MAINTENANCE

- |  |   |
|--|---|
| <ol style="list-style-type: none"> <li>1. Inspect and test the system for proper operations at least every 3 months. Electrolyte levels in wet cell batteries should be checked monthly. Such a check is not required for "maintenance free" battery types.               <ol style="list-style-type: none"> <li>(a) Green "system ready" indicator light should be on, indicating AC power is on and there are no alarm conditions.</li> <li>(b) Unplug the primary pump and the controller from the power supply.</li> <li>(c) Fill the sump with water to the "on" level for the DC pump. Allow the pump to run a few minutes.</li> <li>(d) The alarm will sound approximately 1 second after the pump starts to run.</li> <li>(e) Push the Silence/Reset button. The alarm will turn off.</li> </ol> </li> </ol> | <ol style="list-style-type: none"> <li>(f) The pump will shut off after the water level is lowered and the float drops to the "off" position.</li> <li>(g) Hold silence/ reset button for 3 seconds to reset the controller and clear any alarms or indicators.</li> <li>2. Plug the controller and the primary pump into the wall outlet.               <ol style="list-style-type: none"> <li>(a) The primary pump may come on, lower the water to the "off" level and shut off.</li> <li>(b) The battery light will be yellow when charging. The charger is replacing the energy consumed during the test. The green light will come on after the charger has replaced the energy consumed during the test.</li> </ol> </li> </ol> |
|--|---|

## THE AQUANOT® BATTERY

Zoeller offers its own line of batteries. We offer maintenance-free, deep cycle batteries capable of running the pump continuously for over 5.5 hours. These times are based on continuous pumping at 10' of static head. Actual times will vary depending on static head, volume of water entering the pit, and the condition of the battery.

Follow these recommendations:

- Use a B.C.I. size 27 deep-cycle battery, 175 minute reserve capacity, or larger
- Replace your battery every 3-4 years
- Do not let corrosion build up on the battery terminals
- To check specific gravity, follow the instructions on a hydrometer (wet cell batteries only)
- Use of the included plastic battery box is recommended to keep the battery safe and clean.

**PROTECT YOUR WARRANTY:**

- Water level in batteries must be checked once a month (wet cell batteries only)
- Do not use gel or automotive batteries

## CARBON MONOXIDE DETECTORS

Some battery types used in battery backup systems, regardless of brand or manufacturer, have the potential to give off gaseous by-products when charging. Some of these by-products can produce a rotten egg odor. Also, some of these by-products can cause a CO detector to falsely activate. In order to help prevent false activation, Zoeller Pump Company recommends moving the battery as far away from the CO detector as possible or, if necessary, venting the battery to the exterior. Zoeller Pump Company provides the previous statements only as guidelines to help prevent false activation of the CO detector. In no way are these statements intended to supersede the instructions that accompany the detector, nor do they supersede advice from the CO detector manufacturer.

If the audible alarm associated with your CO detector is activated, we recommend the following actions:

- 1) Take immediate action for personal safety as recommended in the CO detector literature.
- 2) Contact the appropriate agency to determine if the CO is being produced by your furnace, water heater, or any other device which uses natural gas.
- 3) If you are certain that no CO is being produced, a charging battery may be producing gaseous by-products capable of causing the CO detector to activate. Contact the manufacturer and ask for recommendations to prevent the alarm activation.